

LIND[®]
Linear Drive

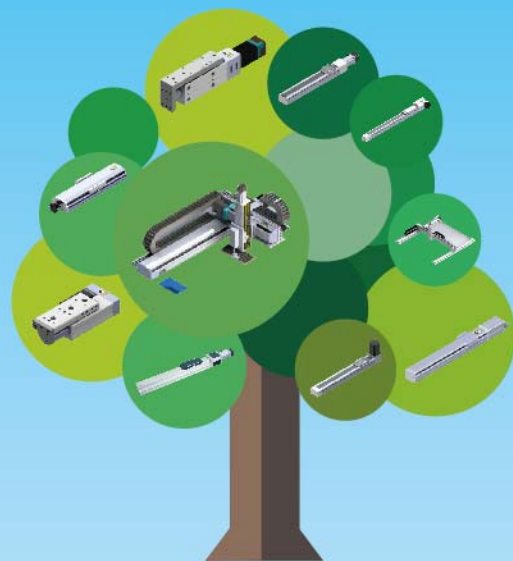

LIND[®]
●
靈德模組系列
Lingde Module Series

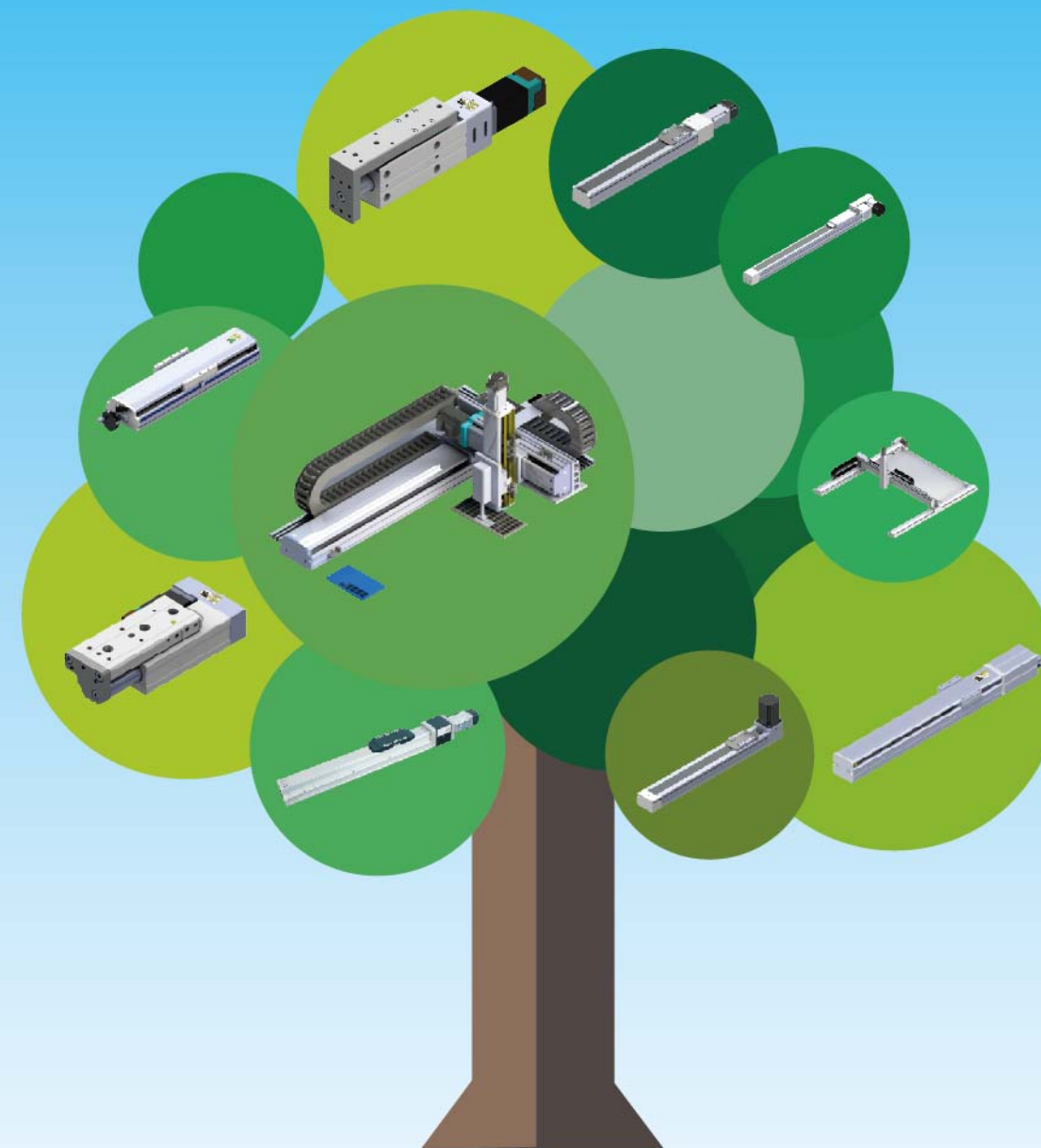

LIND[®]
Linear Drive

無錫靈德自動化科技有限公司
地址：無錫市錫山經濟開發區春筍東路77號
電話：(86) 0510-8855 1360
傳真：(86) 0510-8855 1365
網址：http://www.lind-world.com

Wuxi lind Automation Technology Co., Ltd No. 99,
Furong Zhongsan Road, Economic Development
Zone, Xishan District, Wuxi City, Jiangsu, China
Tel: (86) 0510-8855 1360
Fax: (86) 0510-8855 1365
Website: http://www.lind-world.com

誠招代理經銷商

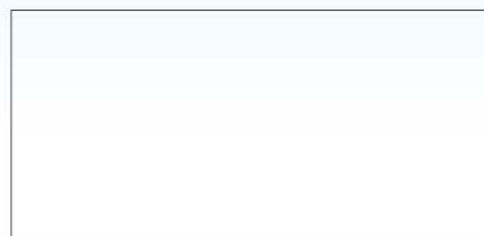

LIND[®] 靈德



模組系列



高效發展 共享擔當



COMPANY BACKGROUND

公司簡介

公司成立於1984年,是臺灣最早一批從事空壓、電驅產品的生產製造型企業;於2015年在無錫設廠,專注於電動缸、伺服壓機、模組的研發、設計、製造與銷售。

Founded in 1984,Lind is one of the earliest manufacturer who is committed to make air compressor,liner driver in Taiwan.Lind Set up the manufacturing plant in wuxi specialized inelectrical cylinder,Servo press,Module,researching,manufacturing ,designing & sales.

BUSINESS CONCEPTS
經營理念

LIND 秉持 高效發展 共享 擔當的理念

創造高品質 高效能 低成本的產品。

LIND Efficient Developing Sharing Responsible

To make the Superior quality, High efficiency, low cost products

企業願景 Enterprise vision

提供更智能化產品服務於人類
Providedinterligentproductsforhumanbeings

企業使命 our mission

成為各自動化設備製造企業的首選配套服務商
Tobethe1stchoicepartnerforAutomatationindustries

核心價值觀 Core values

高效 發展 共享 擔當
Effectivedevelopmentandsharing

企業質量方針 quality policy

靈德產品 必屬精品
Alwaysmakesuperiorqualityproducts

產品索引

Products index

01 標準絲杆滑臺

Standard screw slide

小型LEH6 light Model 低價格 low price 輕負載 light load		本體寬度 60mm Body Width 最大行程600mm.....P15 Max stroke 最大負載 18KG Max Load
小型LEH8 light Model 低價格 low price 輕負載 light load		本體寬度 80mm Body Width 最大行程900mm.....P20 Max stroke 最大負載 30KG Max Load
標準型LEH10 Standard Model 中負載 Medium Load		本體寬度 105mm Body Width 最大行程1100mm.....P25 Max stroke 最大負載 50KG Max Load
標準型LEH13 Standard Model 中負載 Medium Load		本體寬度 135mm Body Width 最大行程1300mm.....P30 Max stroke 最大負載 110KG Max Load
標準型LEH17 Standard Model 大負載 Heavy load		本體寬度 170mm Body Width 最大行程1800mm.....P35 Max stroke 最大負載 120KG Max Load
標準型LEH22 Standard Model 大負載 Heavy load		本體寬度 220mm Body Width 最大行程2000mm.....P40 Max stroke 最大負載 150KG Max Load

02 密封式絲杆滑臺

sealed screw slide

小型LECS light Model 低價格 low price 輕負載 light load		本體寬度 55mm Body Width 最大行程600mm.....P45 Max stroke 最大負載 8KG Max Load
小型LEC6 light Model 低價格 low price 輕負載 light load		本體寬度 65mm Body Width 最大行程600mm.....P49 Max stroke 最大負載 18KG Max Load
標準型LEC10 Standard Model 中負載 Medium Load		本體寬度 105mm Body Width 最大行程1100mm.....P53 Max stroke 最大負載 50KG Max Load
標準型LEC13 Standard Model 中負載 Medium Load		本體寬度 135mm Body Width 最大行程1300mm.....P58 Max stroke 最大負載 110KG Max Load
標準型LEC17 Standard Model 大負載 Heavy load		本體寬度 170mm Body Width 最大行程1400mm.....P63 Max stroke 最大負載 120KG Max Load

05 密封式同步帶滑臺

sealed timing belt slide

標準型LSC6 低價格 low price 輕負載 light load		本體寬度 65mm Body Width 最大行程800mm.....P106 Max stroke 最大負載 8KG Max Load
標準型LBC10 standard model 長行程 long stroke		本體寬度 105mm Body Width 最大行程2550mm.....P109 Max stroke 最大負載 15KG Max Load
標準型LBC10H standard model 長行程 long stroke		本體寬度 105mm Body Width 最大行程2550mm.....P112 Max stroke 最大負載 20KG Max Load
標準型LBC13 standard model 長行程 long stroke		本體寬度 135mm Body Width 最大行程3100mm.....P117 Max stroke 最大負載 17KG Max Load
標準型LBC13H standard model 長行程 long stroke		本體寬度 135mm Body Width 最大行程3100mm.....P120 Max stroke 最大負載 30KG Max Load
標準型LBC17H standard model 長行程 long stroke		本體寬度 154mm Body Width 最大行程4500mm.....P125 Max stroke 最大負載 80KG Max Load
標準型LBC17H standard model 長行程 long stroke		本體寬度 154mm Body Width 最大行程4500mm.....P128 Max stroke 最大負載 60KG Max Load

06 半封閉同步帶滑臺

Semi sealed timing belt slide

標準型LES13 standard model 低價格 low price 中負載 Medium Load		本體寬度 134mm Body Width 最大行程1500mm.....P133 Max stroke 最大負載 110KG Max Load
-----------------------------------------------------------------------------	-------------------------------------------------------------------------------------	-----------------------------------------------------------------------------------------

03 歐規同步帶滑臺

EURO Type timing belt slide

標準型LBC6 Standard Model 低價格 low price 長行程 long stroke		本體寬度 65mm Body Width 最大行程3000mm.....P68 Max stroke 最大負載 9KG Max Load
標準型LBC6H Standard Model 低價格 low price 長行程 long stroke		本體寬度 65mm Body Width 最大行程3000mm.....P71 Max stroke 最大負載 22KG Max Load
標準型LB8 Standard Model 低價格 low price 長行程 long stroke		本體寬度 80mm Body Width 最大行程5700mm.....P76 Max stroke 最大負載 80KG Max Load
標準型LB8H Standard Model 低價格 low price 長行程 long stroke		本體寬度 80mm Body Width 最大行程5700mm.....P79 Max stroke 最大負載 100KG Max Load



04 半封閉同步帶滑臺

semi sealed timing belt slide

標準型LB10 Standard Model 長行程 long stroke		本體寬度 105mm Body Width 最大行程2550mm.....P82 Max stroke 最大負載 15KG Max Load
標準型LB10H Standard Model 長行程 long stroke		本體寬度 105mm Body Width 最大行程2550mm.....P85 Max stroke 最大負載 20KG Max Load
標準型LB13 Standard Model 長行程 long stroke		本體寬度 135mm Body Width 最大行程3100mm.....P90 Max stroke 最大負載 17KG Max Load
標準型LB13H Standard Model 長行程 long stroke		本體寬度 135mm Body Width 最大行程3100mm.....P93 Max stroke 最大負載 30KG Max Load
標準型LB17 Standard Model 長行程 long stroke		本體寬度 170mm Body Width 最大行程4500mm.....P98 Max stroke 最大負載 80KG Max Load
標準型LB17H Standard Model 長行程 long stroke		本體寬度 170mm Body Width 最大行程4500mm.....P101 Max stroke 最大負載 60KG Max Load

07 微型絲杆滑臺

Mini type Screw slide

標準型LSH20 Standard Model 長行程 long stroke		本體寬度 20mm Body Width 最大行程50mm.....P135 Max stroke 最大負載 5KG Max Load
標準型LLH20 Standard Model 短行程 short stroke		本體寬度 20mm Body Width 最大行程50mm.....P137 Max stroke 最大負載 5KG Max Load

08 軌道內嵌型電動滑臺

built in guildeay electri slide

LBTH40		本體寬度 44mm Body Width 最大行程500mm.....P139 Max stroke 最大荷重 25KG Max Load
LBTH50		本體寬度 54mm Body Width 最大行程800mm.....P143 Max stroke 最大荷重 30KG Max Load
LBTH80		本體寬度 82mm Body Width 最大行程1000mm.....P147 Max stroke 最大荷重 50KG Max Load
LBTH120		本體寬度 120mm Body Width 最大行程1000mm.....P151 Max stroke 最大荷重 110KG Max Load

單軸規格選型表

Single axis specification sheet

公司 Company	填写日期 Register Date	联系人 Contact
部门 Dept	电话 Tel	分机 Ext
E-mail	手机 Mobile	地址 Address

单轴需求 Single axis required

行程: Stroke (mm):	重复定位精度: repeatability (mm)	使用环境: Usage Environment
速度: Speed (mm/s):	□ ±0.006	□ 一般 General
负载: Payload (kg):	□ ±0.02	□ 无尘 (洁净型) Dust-free (Cleanness type)
	□ ±0.04	(洁净度 Cleanliness: 10 100 1000)
	□ 其它 (Other) _____	

安装方式 Installation Way	全平面固定 Fixed whole-plane		
	水平安装 Horizontal	侧面安装 Side	垂直安装 Vertical

空间需求 Space required	空间宽松结构选择 Loose model choice	丝杆样式 Ball Screw Drive □ M □ BC	皮带样式 Belt Drive □ R □ L
	空间紧凑结构选择 Compact model choice	丝杆样式 Ball Screw Drive □ BR □ BL □ BD	皮带样式 Belt Drive □ LU □ RU □ RD □ LD

马达外置可增加功率
Motor Power can be increased by external installed

感应器 Sensor	□	□		
机台用途 Applications	<input type="checkbox"/> 非标装配机 Automatic Assembly Machine <input type="checkbox"/> 锁螺丝机 Auto-Screwdriving Machine	<input type="checkbox"/> 贴标机 Labeling Machine <input type="checkbox"/> 喷涂机 Spraying Machine	<input type="checkbox"/> 贴膜机 Film Sticking Machine <input type="checkbox"/> CCD视觉检测机 CCD Visual Inspection Equipment	<input type="checkbox"/> 贴合机 Laminating Machine <input type="checkbox"/> 上下料机 Loading and Unloading Equipment
备注 Remarks				

多軸規格選型表

Multi Axis Specification sheet

公司 Company	填写日期 Register Date	联系人 Contact
部门 Dept	电话 Tel	分机 Ext
E-mail	手机 Mobile	地址 Address

多轴需求 Multi Axis Required

行程 Stroke (mm) X: Y: Z:	重复定位精度: Repeatability (mm)	使用环境: Usage Environment
速度 Speed (mm/s) X: Y: Z:	□ ± 0.01	□ 一般 General
负载 Payload (kg):	□ ± 0.02	□ 无尘 (洁净型) Dust-free (Cleanness type)
	□ ± 0.04	(洁净度 Cleanliness: 10 100 1000)
	□ 其它 (Other) _____	

组合类型 Combination Types	悬臂型 Arm Type				
	龙门型 Gantry Type				
	极坐标型 Moving Arm Type				
	十字型 XZ Type				

多轴样式 Multi-axis Type				
	<input type="checkbox"/> 悬臂两轴型 (A) Arm type with 2-axis(A)	<input type="checkbox"/> 悬臂三轴型 (A) Arm type with 3-axis(A)	<input type="checkbox"/> 龙门两轴型 (G) Gantry type with 2-axis(G)	<input type="checkbox"/> 龙门三轴型 (G) Gantry type with 3-axis(G)
	<input type="checkbox"/> 同动龙门两轴型(G) Spontaneous Moving Gantry type with 2-axis(G)	<input type="checkbox"/> 十字型两轴型(F) XY type with 2-axis(F)	<input type="checkbox"/> 极坐标两轴型(P) Moving arm type with 2-axis(P)	<input type="checkbox"/> 极坐标三轴型(P) Moving arm type with 3-axis(P)

感应器 Sensor	<input type="checkbox"/> 光电式 (外置) Optoelectronic type (External)	<input type="checkbox"/> 金属接近式 (外置) Metal induction type (External)			
机台用途 Applications	<input type="checkbox"/> 非标装配机 Automatic Assembly Machine <input type="checkbox"/> 锁螺丝机 Auto-Screwdriving Machine	<input type="checkbox"/> 贴标机 Labeling Machine <input type="checkbox"/> 喷涂机 Spraying Machine	<input type="checkbox"/> 贴膜机 Film Sticking Machine <input type="checkbox"/> CCD视觉检测机 CCD Visual Inspection Equipment	<input type="checkbox"/> 贴合机 Laminating Machine <input type="checkbox"/> 上下料机 Loading and Unloading Equipment	<input type="checkbox"/> 其他 Other
备注 Remarks					

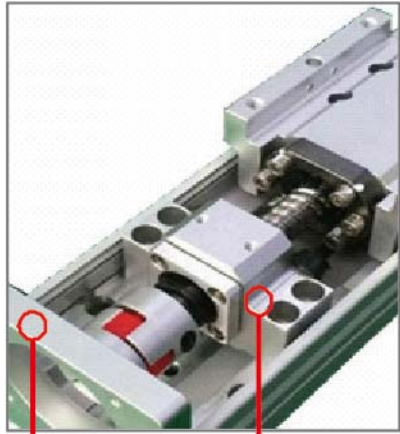

馬達安裝法蘭與軸承座為分體式結構，容易導致馬達軸心與絲杆軸心偏差過大影響連軸器壽命。

others flange and bearing splited type,makes Axis of motor and screw Deviation easily,and affect the service lif of the couling

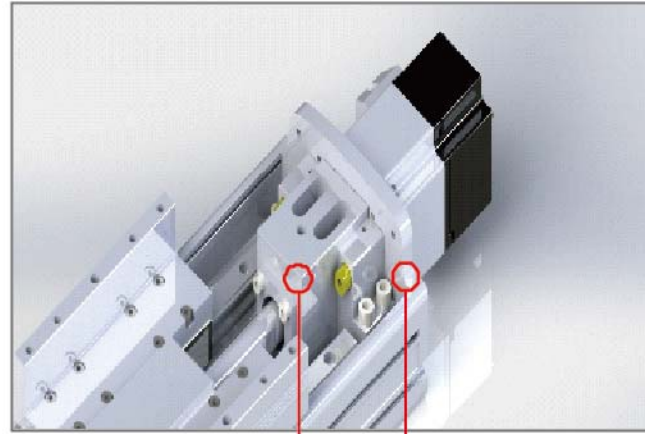

LIND單軸機械手，軸承座和電機安裝法蘭為一體式結構。馬達軸與絲杆軸端高度同心極大延長各部件使用壽命。

Lind Single Axis manipulator,using intergated type for motor flange and bearing,Makes high Concentricity of the screw and motor axis,and extends the service life of all the parts

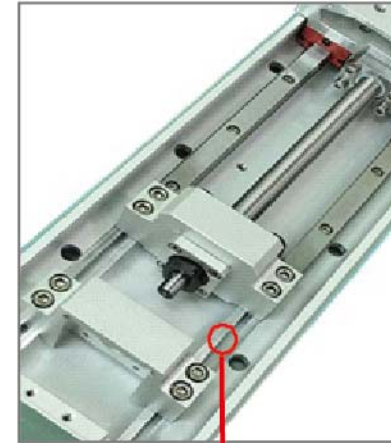

導軌安裝面和軸承安裝座均為T型槽安裝，滑臺在高強度運行時容易導致安裝螺絲鬆動

Other's track mounting surface and bearing seat both are T-groove installation, the slide in high-strength operation can easily lead to screws loose mounted

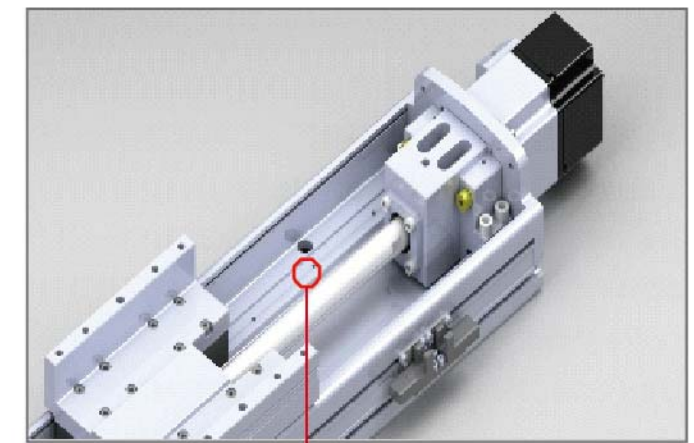

LIND機械手所有安裝面均經過CNC設備加工，且導軌安裝孔均為螺紋孔安裝，確保運行平穩，平面精度達標。

LIND's products,all mounting surfaces of the manipulator are machined by CNC and the track mounting holes are threaded ensuring smooth operation and flatness

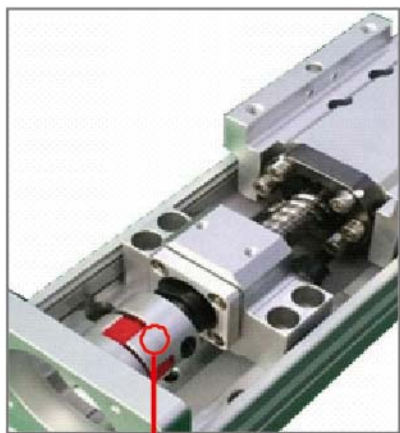

橡膠梅花聯軸器不合適伺服電機配用。

others using Rubber plum coupling in the products,which is not siutable for servo application

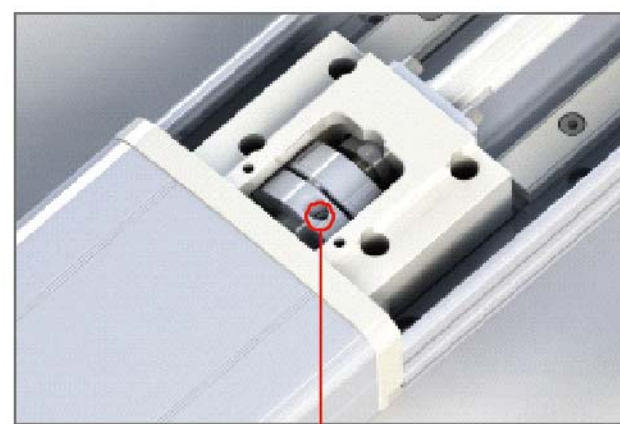

LIND連軸器均採用膜片聯軸器，適合伺服電機的高轉速以及高精度定位。

Lind is using membrane coupling which is suitable for high speed and high precision positioning of servo motors

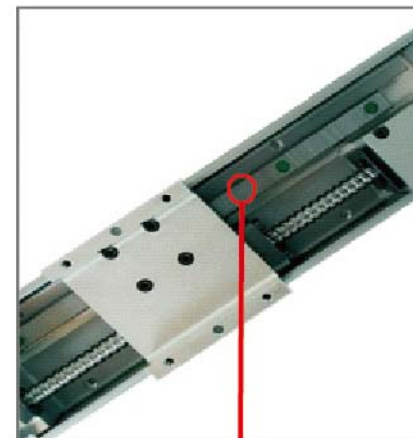

常見100mm或105mm寬度的單軸機械手大多是以單根導軌導向或雙根12mm微型導軌導向為主。運行平穩度和壽命均不理想。

in the market,other normally make 100mm or 105mm width single axis manipulator are mainly guided by a single guide rail or two 12mm miniature guide rails. The running smoothness and life are restricted



LIND105mm寬度的單軸機械手均採用雙根15MM（4列滾珠）導向，運行平穩，抗扭矩強。

LIND is using 2 pcs of 15mm guideways to make 105mm width single axis manipulator,asured the running smoothly and Anti-torque strongly

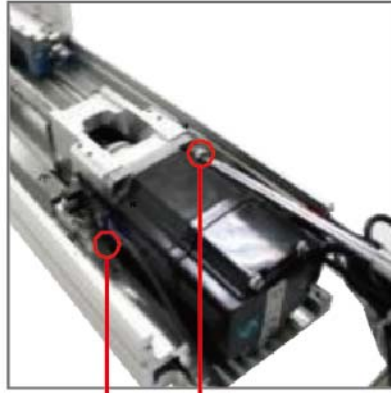

馬達內置式單軸機械手，安裝馬達需要特長內六角扳手，且馬達下側螺絲安裝難度大。

Motor built-in type single-axis manipulator, installation of the motor requires a long hex socket wrench, and the screw under the motor is difficult to handle

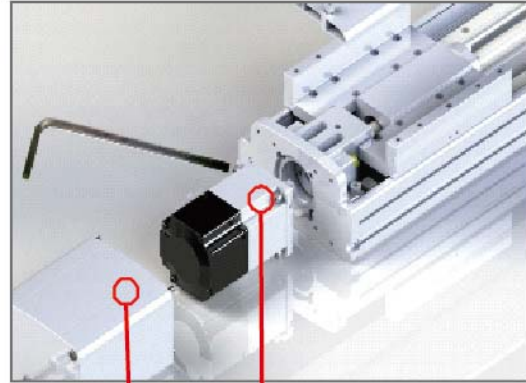

LIND馬達內置型單軸機械手，只需打開馬達罩就可輕易安裝馬達，方便快捷。

Motor built-in type single-axis manipulator, The motor can be easily installed after open the cover, it is quite convenient



密封鋼帶與滑臺結合處為接觸式摩擦，運行一段時間後密封鋼帶出現表面刮花，產生粉塵，甚至斷裂。

It is contact friction between Sealed copper belt and slides, after a period of operation, the sealed copper belt would have surface scratches, dust, and even broken



LIND 密封鋼帶採用德國進口材質且通過特殊結構設計，鋼帶上表面不與滑臺接觸，有效防止鋼帶刮花和粉塵產生。

Sealed copper belt is made of German material and it is designed with special structure, the surface of the copper belt does not contact with the slide directly, effectively preventing the scratching of the copper strip and dust

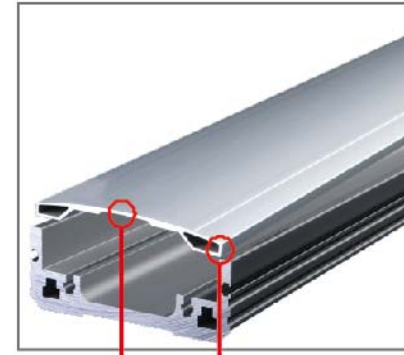

普通上蓋採用單層鋁合金，沒有加強筋，由於行程過長會導致上蓋塌陷，變形。

The upper cover is using a single layer of aluminum alloy, no reinforced ribs, it will lead to the upper cover collapsed deformed easily if it is long stroke



LIND所有上蓋採用中空結構，內置加強筋，可做超長行程，不塌陷，不變形。

All upper cover with hollow structure, built-in reinforcing ribs, suitable for long stroke products, No collapse No deformation.

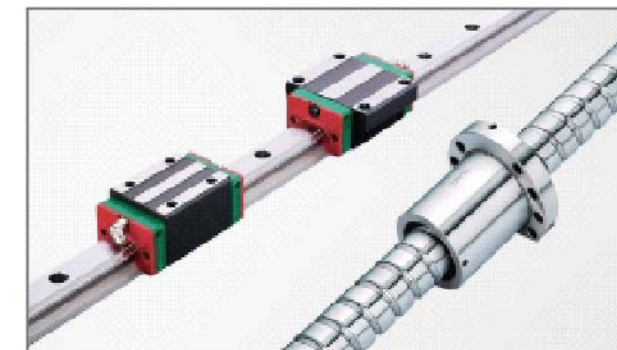
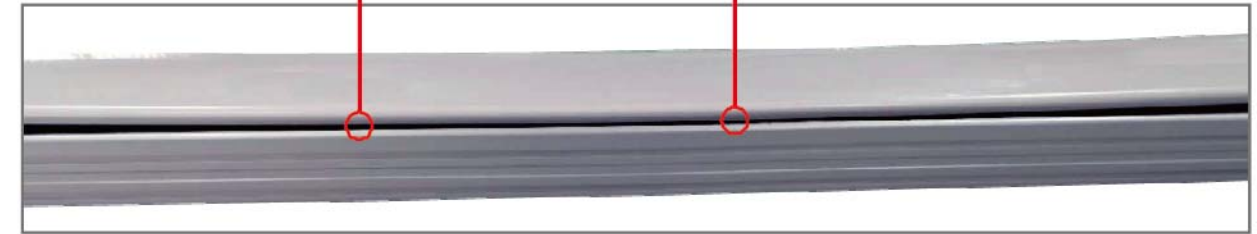

高品質配件

Lind uses high quality spare parts only





懸臂兩軸 (A型)
Arm type with 2 axis (A series)

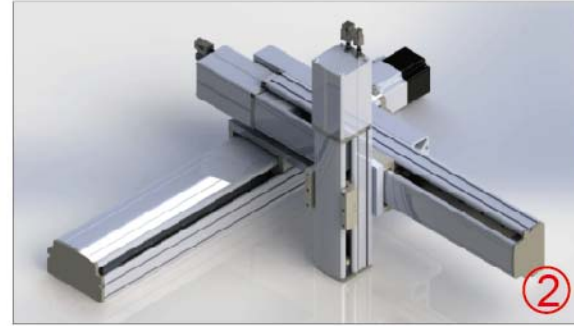

懸臂三軸 (A型)
Arm type with 3 axis (A series)



十字兩軸(F型-水平安裝)
Cross 2 axis (F series-Horizontal)



十字兩軸(F型-Y軸本體運動)
Cross 2 axis (F series-movement by Y axis)



懸臂三軸 (A型-Z軸本體運動)
Arm type with 3 axis (A series)



懸臂六軸 (A)
Arm type with 6 axis (A series)



極坐兩軸(P型)
Moving arm type with 2 axis (P series)



極坐標三軸(P型)
Moving arm type with 3 axis (P series)



十字兩軸 (F型)
Cross 2 axis (F series)



十字兩軸 (F型-Z軸本體運動)
Cross 2 axis (F series-movement by Z axis)



極坐標兩軸(P型-Y軸本體運動)
Moving arm type with 2 axis



極坐標六軸
Moving arm type with 6 axis



龍門兩軸(G型)
Gantry 2 axis (G series)

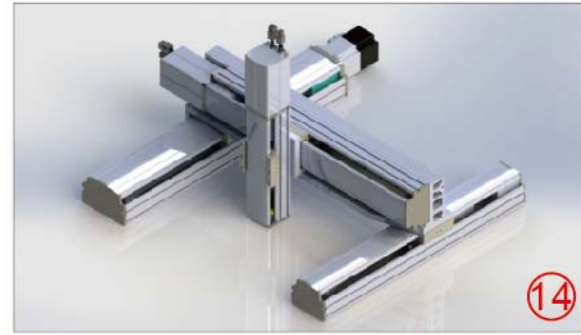

龍門三軸(G型)
Gantry 3 axis (G series)

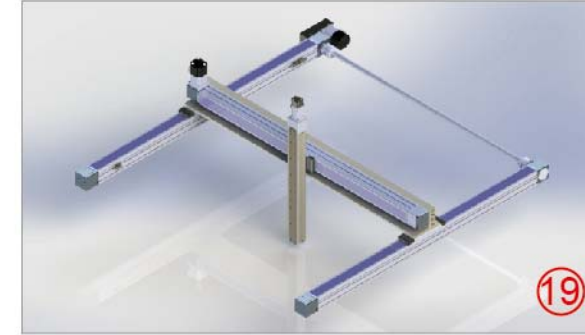

龙门同动三轴(G型-Z轴本体运动)
Spontaneous moving gantry type with 3 axis
(G series-movement by Z axis)



龙门复合组合(G型)
Gantry combinatorial association (G series)

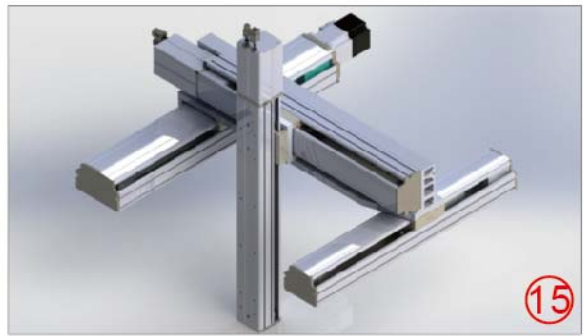

龍門三軸(G型-Z軸本體運動)
Gantry 3 axis (G series)



龍門同動一軸(G型)
Gantry axi in spontaneous moving

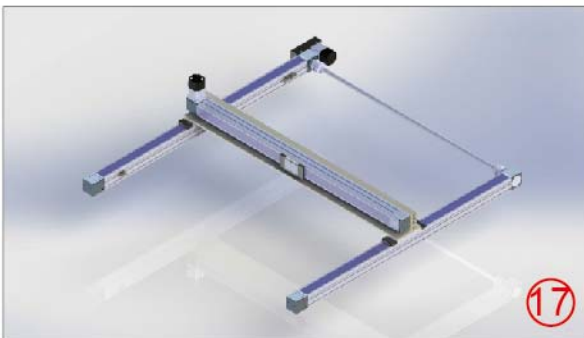

龍門同動兩軸(G型)
Spontaneous moving gantry type with 2 axis



龍門同動三軸(G型-Z軸本體運動)
Spontaneous moving gantry type with 3 axis



定制加长型
Custom lengthening

■ 機器人控制系統 ROBOT CONTROL SYSTEM



■ IC芯片码垛 IC chip stacking

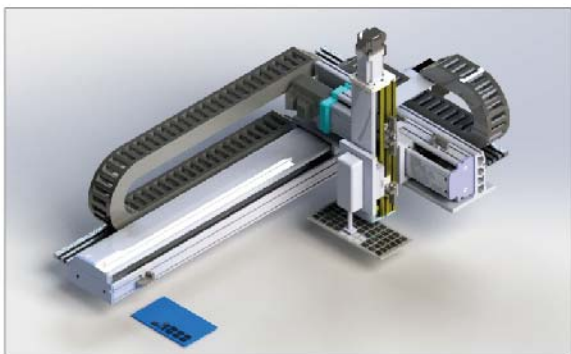

■ 大型零件拾放 large parts picking and placing

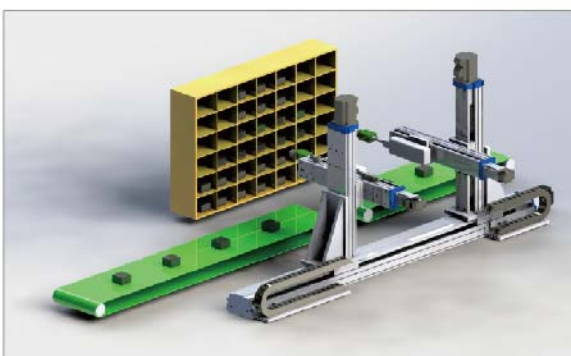

■ Delta机器人物品分拣 Delat robot items sorting



■ 大型液晶屏点胶 large LCD screen dispensing



■ 电子零件检测 electronic parts detection

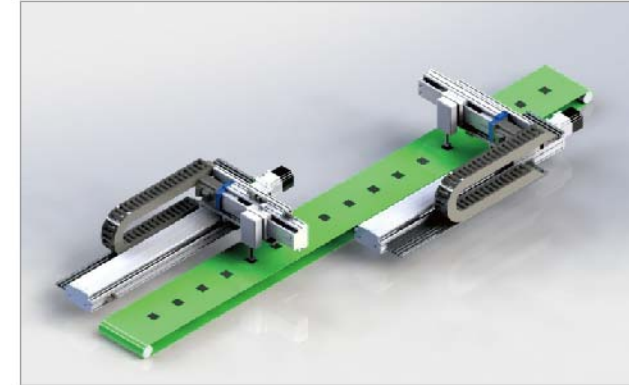

■ 多工位协同作业 Multi-station co-operation

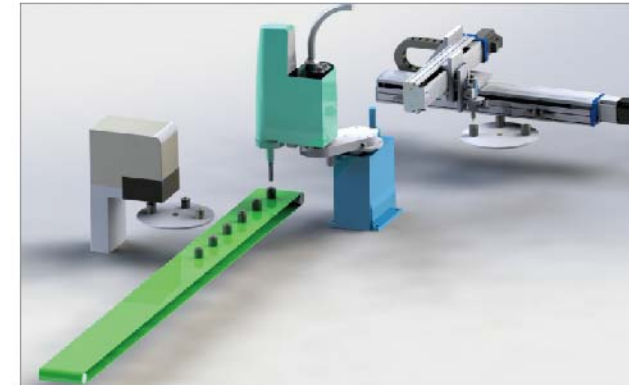

■ 高速搬 high speed movement



■ 高速喷墨 high speed inkjet

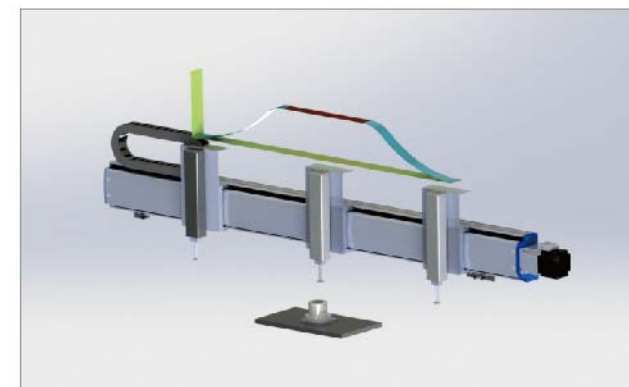

■ 堆叠码垛 stacking

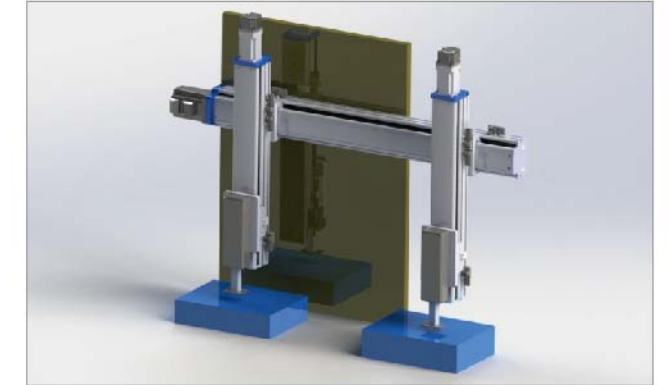

■ 复合零件拾放 Composite part picking and placing

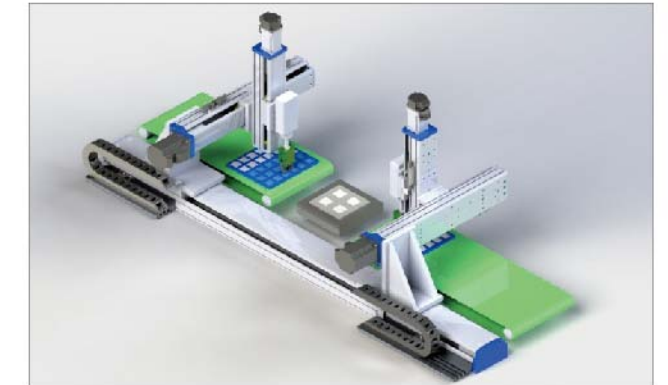

■ 高速复合搬运 high speed Composite movement



■ 工件搬运 spare parts movement

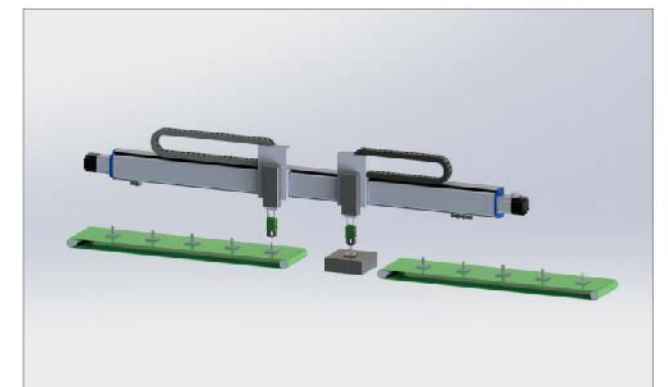

■ 工件排列 workpiece arrangement

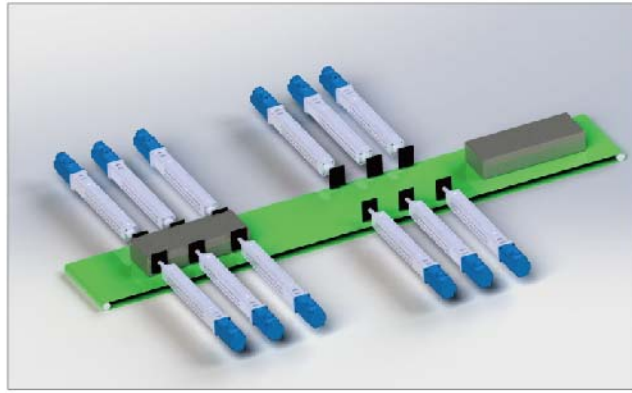

■ 工件压入 work piece press in

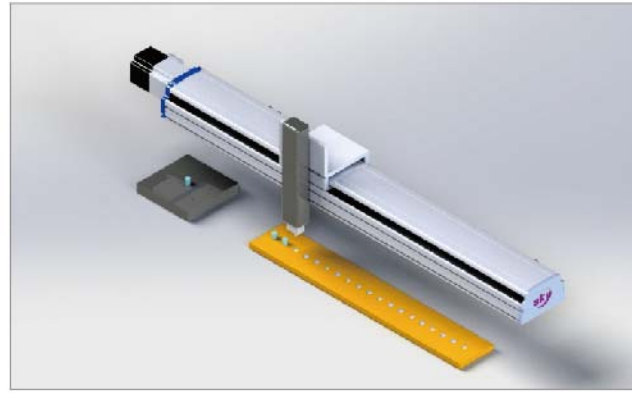

■ 贴片装置 Patch Device

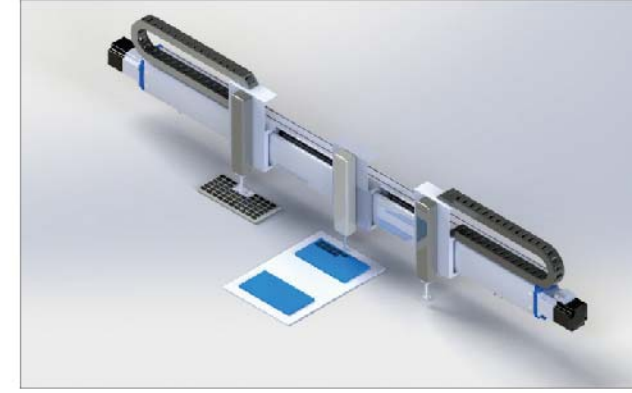

■ 向多台检测装置取放零件 Pick and place parts against multiple inspection devices

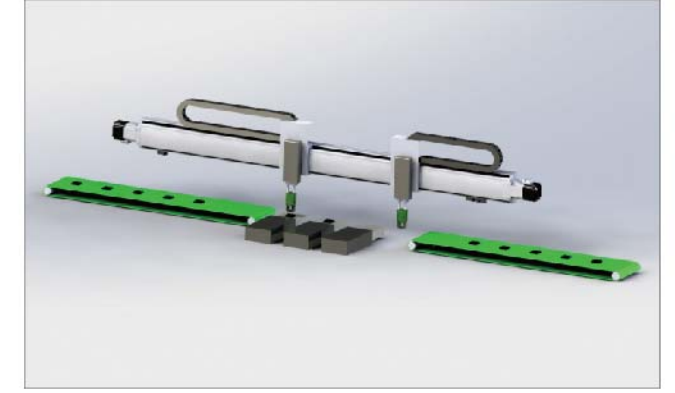

■ 零件涂胶 Spare parts glueing

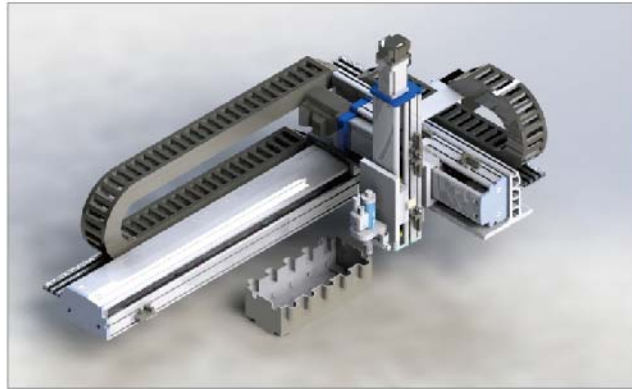

■ 配套压和 Matching press



■ 协作点胶 Collaborative dispensing

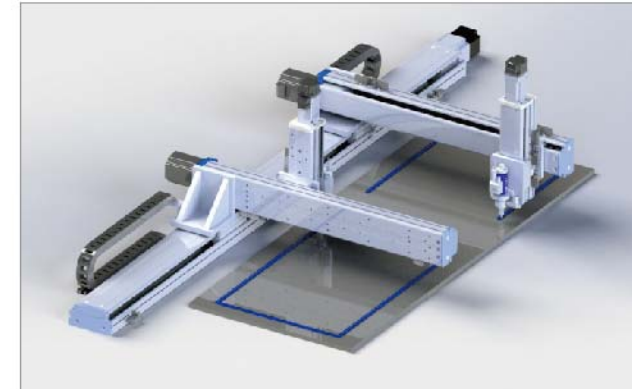

■ 协作锁螺丝 Collaborative lock the screw

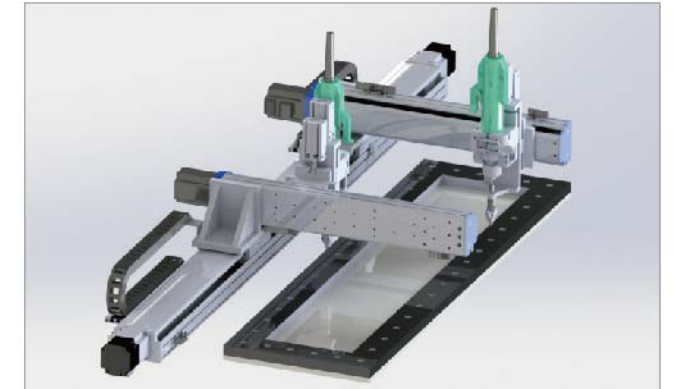

■ 三维涂胶 3D glueing

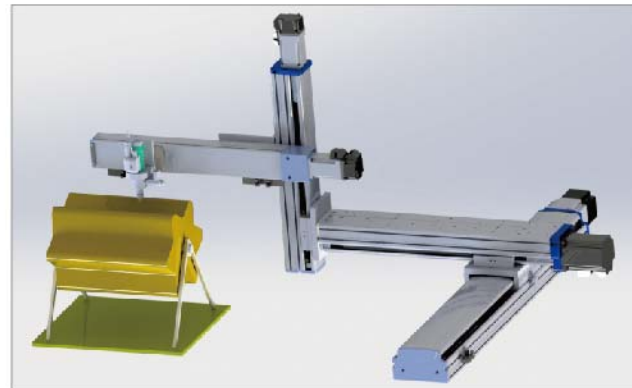

■ 双开门装置 double door Device

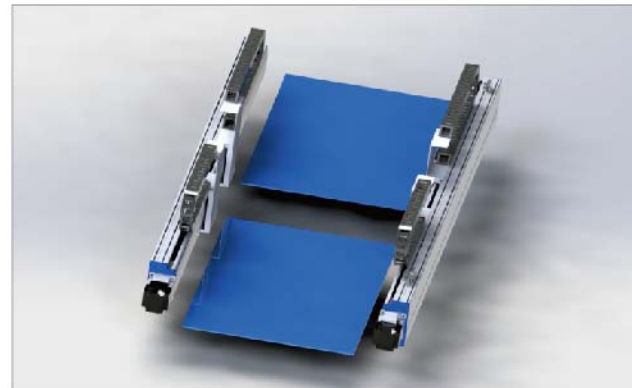

■ 重负荷码垛 heavy load stacking



■ 双面同时检测 Double-sided simultaneous detection

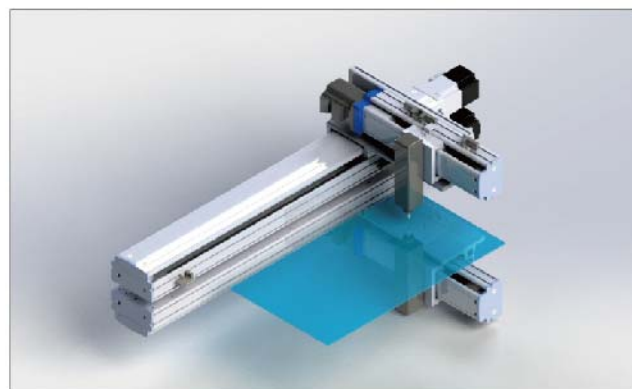

■ 锁螺丝 lock the screw

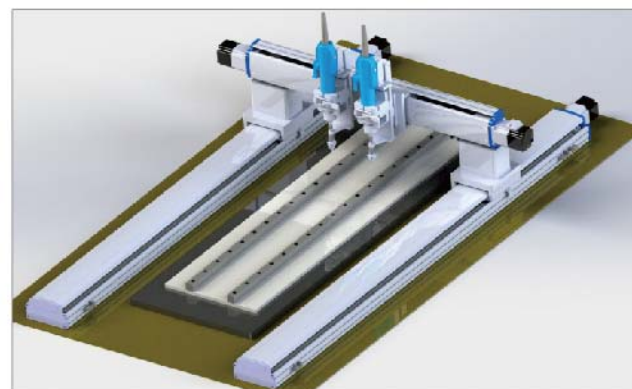

標準滾珠絲杆驅動-LEH6

STANDARD BALL SCREW SLIDE

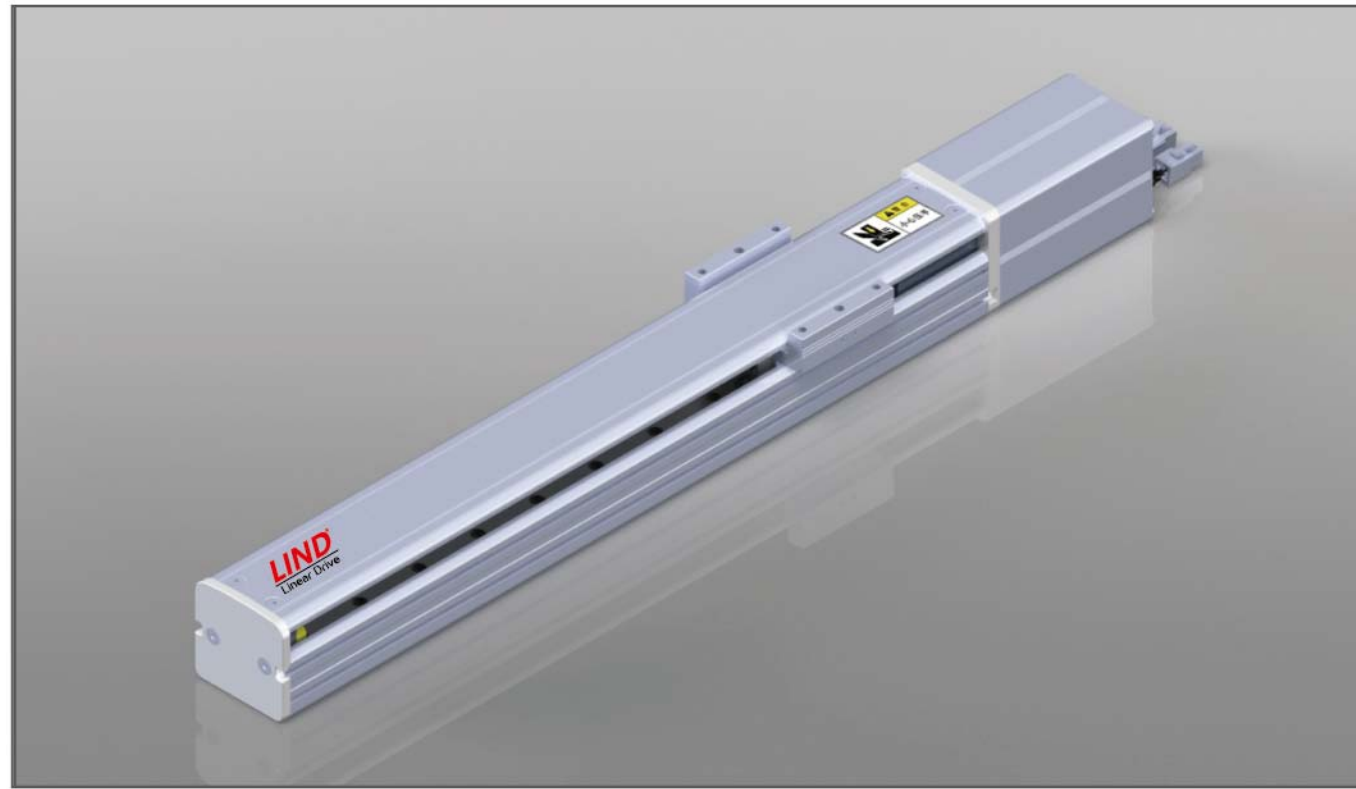

馬達安裝方式 Motor direction

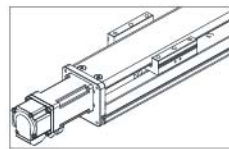

馬達直連外置-BC
Motor Exposed

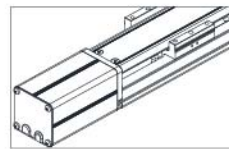

馬達直連內置-M
Motor built-in

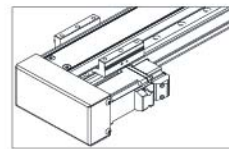

馬達左折-BL
Motor Left Side

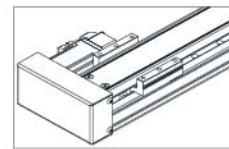

馬達右折-BR
Motor Right Side

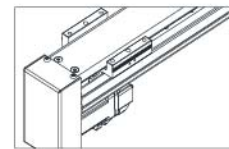

馬達下折-BD
Motor Bottom Side

型號表示方式 Guide for Model Selection

LEH6 - L10 - C - S100 - BC - ZP10B - T3 - 001

本體型號 Base Style	絲杆導程(螺距) Ball Screw Lead	精度等級 Accuracy class	行程mm Stroke(mm)	馬達方式 Motor way	馬達品牌 Motor Type	馬達功率 Motor power	感應開關數量 Sensor quantity	感應器類型 Sensor type	備註 Non-standard,d.c.
	L5 5mm	C 普通級C7 Common precision	50-600	BC 直連外置	P 聯下	10 100W	T3 3PCS	無 NPN	
	L10 10mm	P 研磨級C5 High precision		*M 直連內置	M 三菱	20 -	T2 2PCS	P PNP	
				BL 左折	T 臺達	40 -	T1 1PCS		
				BR 右折	Y 安川		E 無光電開關		
				BD 下折	S7 57步進電機				
				Z 客戶自配電機 我司配電機	其他品牌電機				
						剎車 Brakes			
						無 無剎車			
						B 帶剎車			

*導程：電機旋轉一週，滑臺移動的直線距離。

基本規格 Specification

馬達功率(W) Motor Output(W)	100W	
滾珠絲杆導程-螺距(mm) Belt Lead(mm)	5	10
最高速度(mm/s) Maximum Payload(mm/s)	250	500
最大負載 Rated load(kg)	水平使用 Horizontal	18
	垂直使用 Vertical	8
額定推力 Rated thrust(N)	341	170
行程範圍 Range of travel(mm)	50-600MM/50行程遞增	
絲杆外徑 Screw diameter(mm)	φ12	
重複位置精度 Repeatability(mm)	C7(C)	±0.01
	C5(P)	±0.006
導軌規格 Guide specification	8.5X24	
聯軸器 coupling	8X8	
感應器 sensor	EE-SX674(NPN)	

*馬達加減速度時間為0.2S
motor speed is 0.2S.

*如有特殊行程請先與技術人員聯系
in case special stroke please contact technical services.

安裝示意圖 Installation Instrations&Dimentions

安裝方法一：

安裝螺絲從下往上安裝

*注意鎖緊螺絲裝入滑臺的長度不得超過10mm，否則會與內部干涉。

method 1

fix the screw from bottom to up direction

Note that the length of the locking screw installed in the slide shall not exceed 10mm, otherwise it will interfere with the internal.

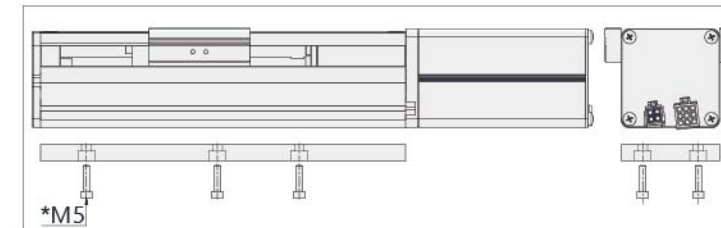

安裝方法二：

打開滑臺上蓋，安裝螺絲從上往下安裝。

method 2:

open the cover, fix the screw from up to bottom

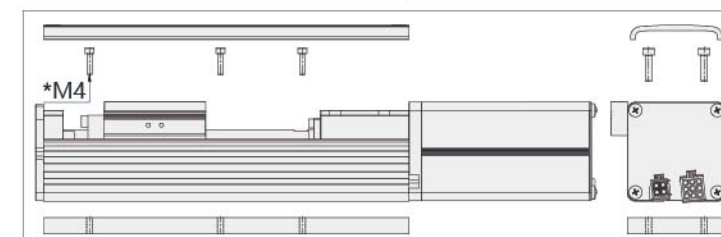

傳感器接綫圖 Sensor Wiring diagram

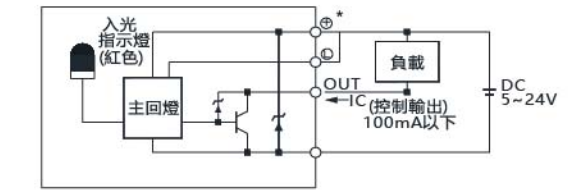

速度與行程 Speed and stroke

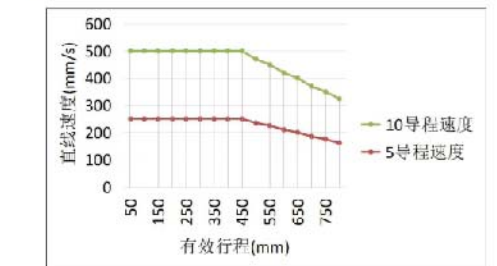

行程超過500時，絲杆旋轉會產生共振，此時請將速度調低。

When the stroke is more than 500, the rotation of the screw will cause resonance, and then the speed will be lowered.

靜態力矩表 Static torque gauge

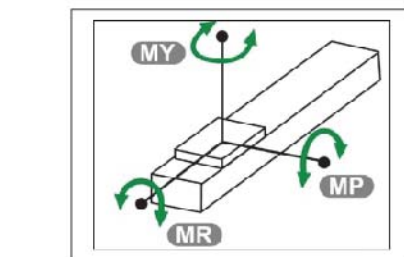

MY	32 (N.M)
MP	40 (N.M)
MR	28 (N.M)

馬達直連外置-BC Motor Exposed

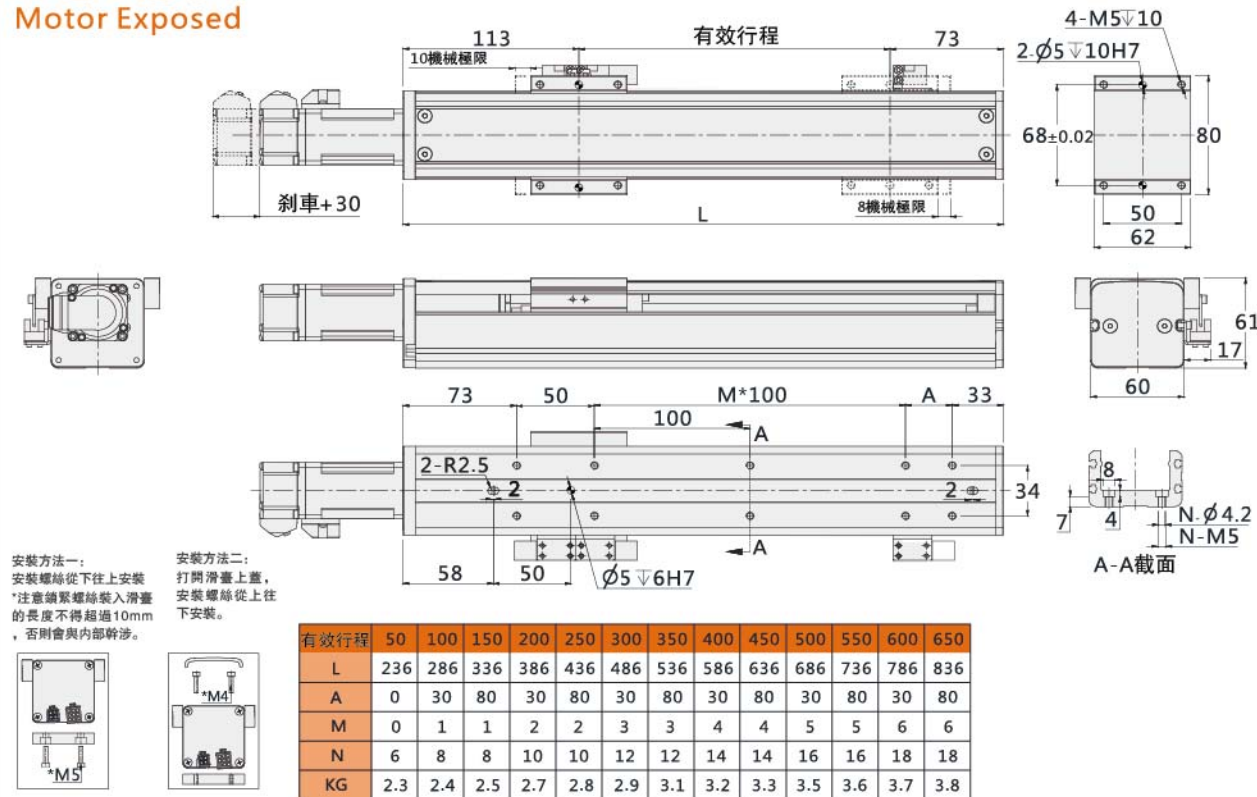

注：以上不含電機重量。Note: Not including motor weight.
如有特殊行程請先與技術人員聯繫。in case special stroke please contact technical services.

馬達左折-BL Motor Left Side

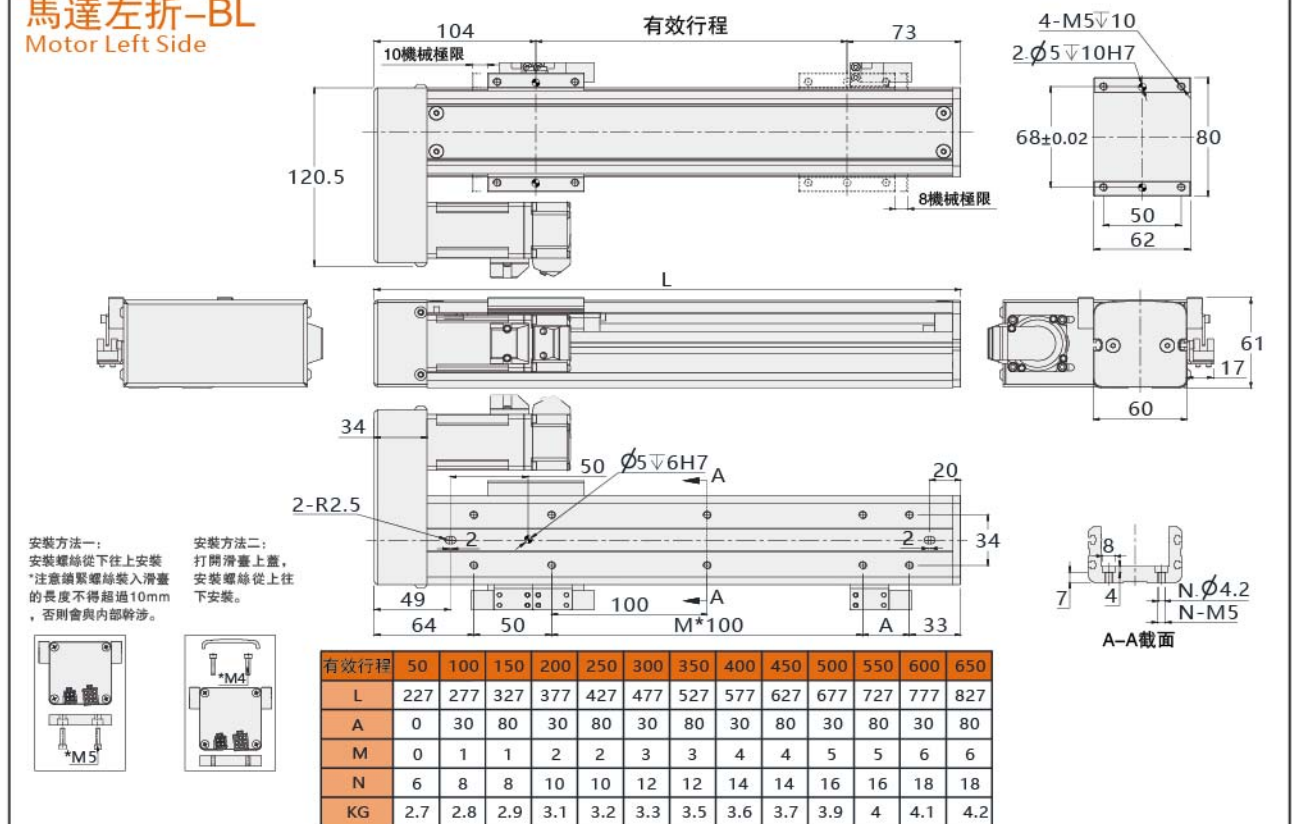

注：以上不含電機重量。Note: Not including motor weight.
如有特殊行程請先與技術人員聯繫。in case special stroke please contact technical services.

馬達直連內置-M Motor built-in

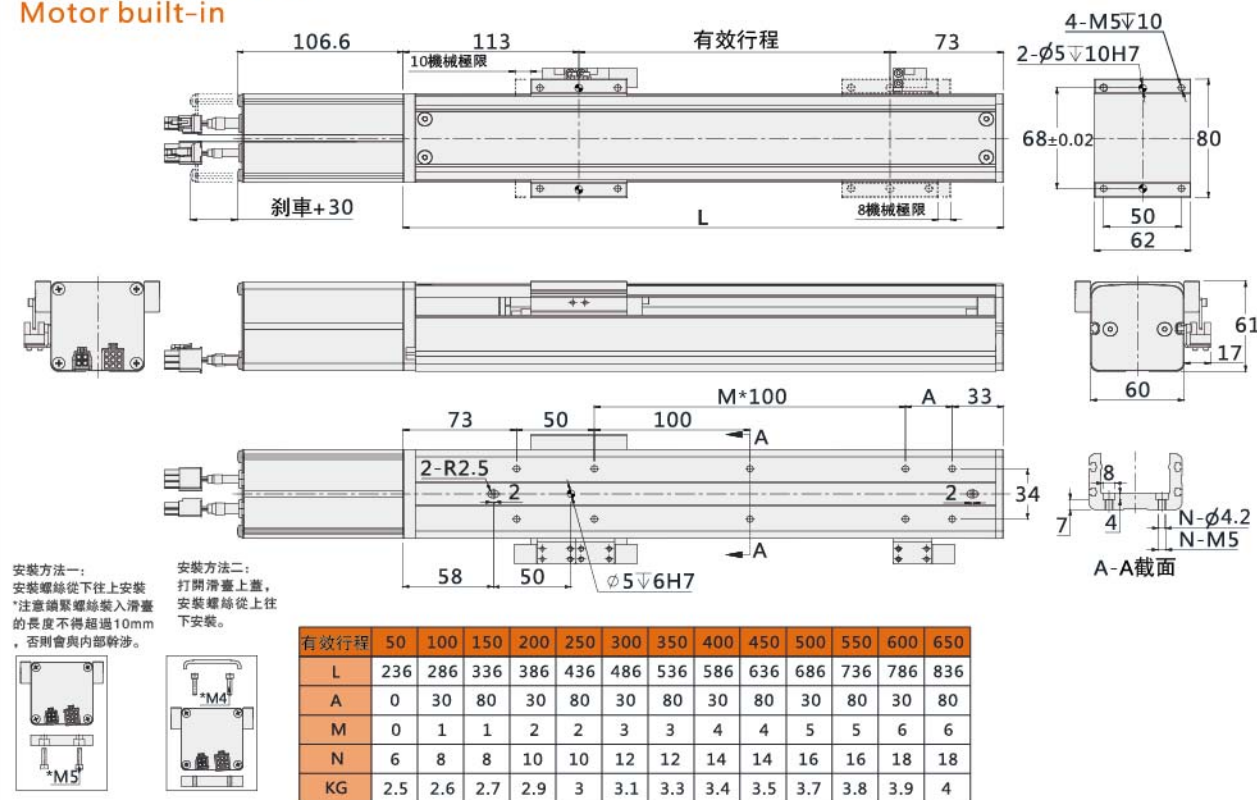

注：以上不含電機重量。Note: Not including motor weight.
如有特殊行程請先與技術人員聯繫。in case special stroke please contact technical services.

馬達右折-BR Motor Right Side

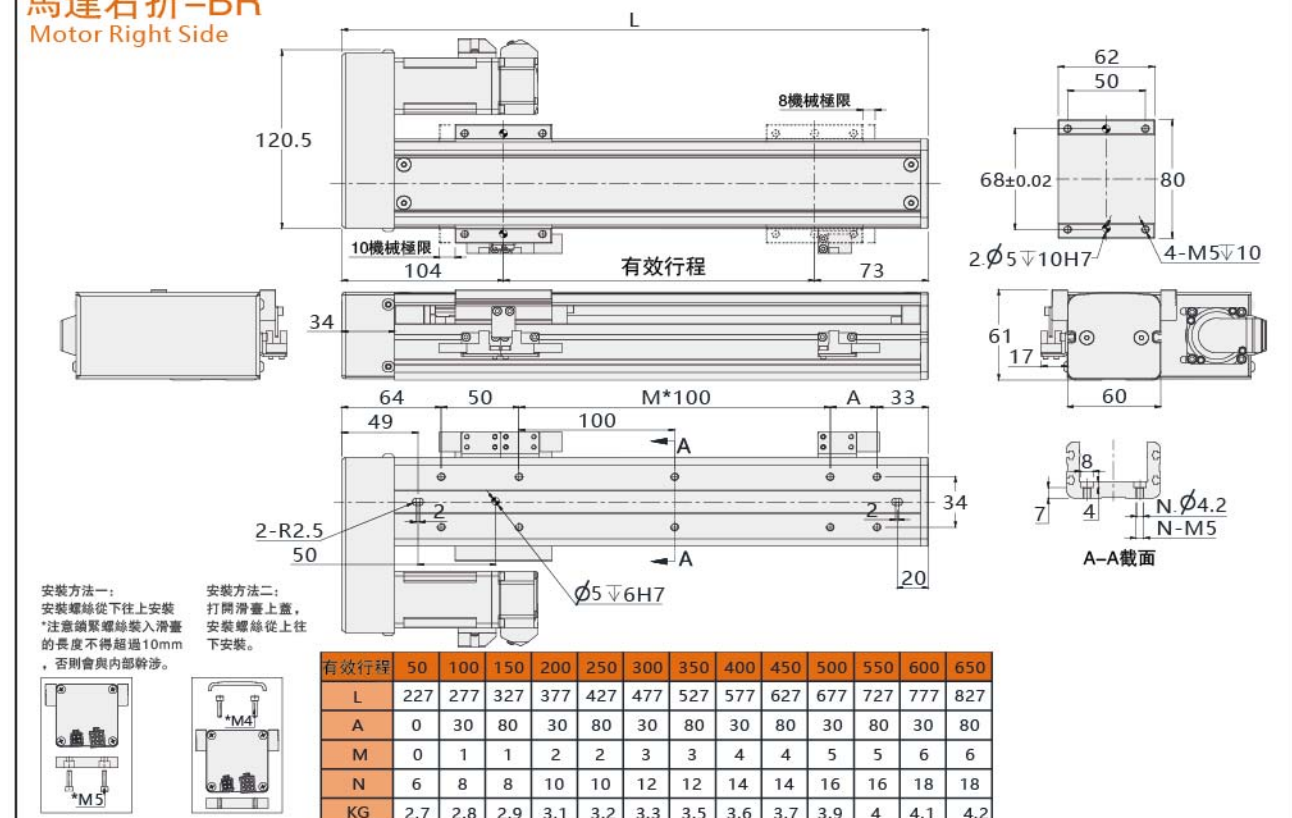

注：以上不含電機重量。Note: Not including motor weight.
如有特殊行程請先與技術人員聯繫。in case special stroke please contact technical services.

馬達下折-BD
Motor Bottom Side

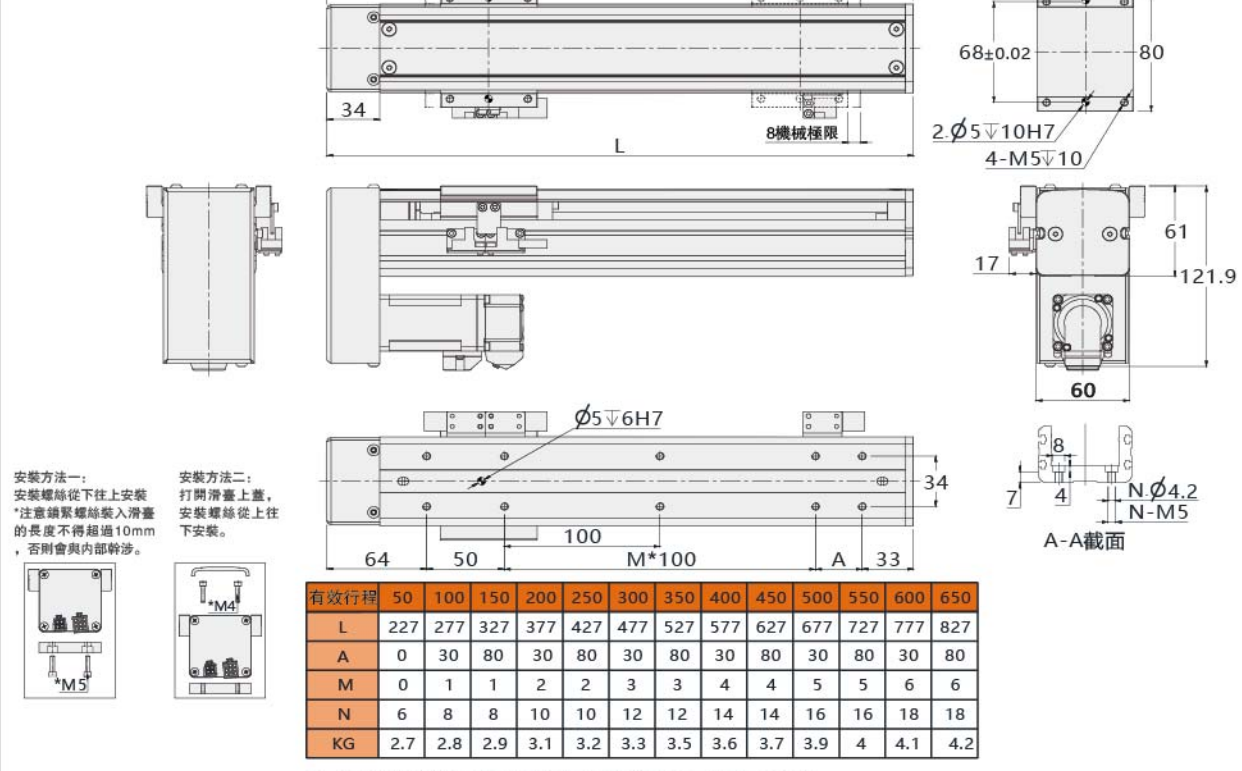

安裝方法一：
安裝螺絲從下往上安裝
*注意鎖緊螺絲裝入滑臺
的長度不得超過10mm
，否則會與內部干涉。

安裝方法二：
打開滑臺上蓋，
安裝螺絲從上往
下安裝。

注：以上不含電機重量。Note: Not including motor weight.
如有特殊行程請先與技術人員聯繫。in case special stroke please contact technical services.



馬達安裝方式 Motor direction

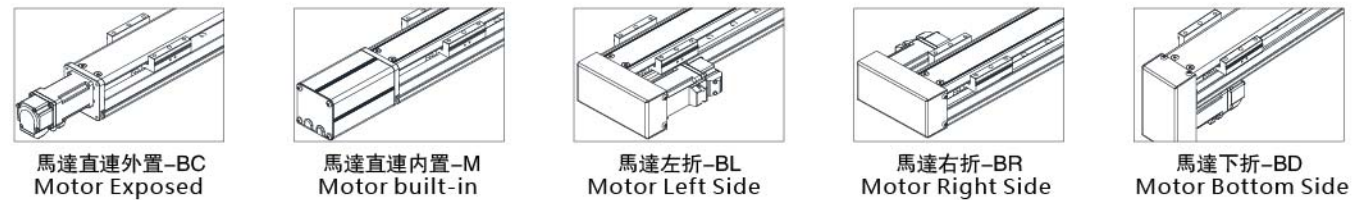

型號表示方式 Guide for Model Selection

LEH8-L10-C-S100-BC-ZP10B-T3 _ - 001

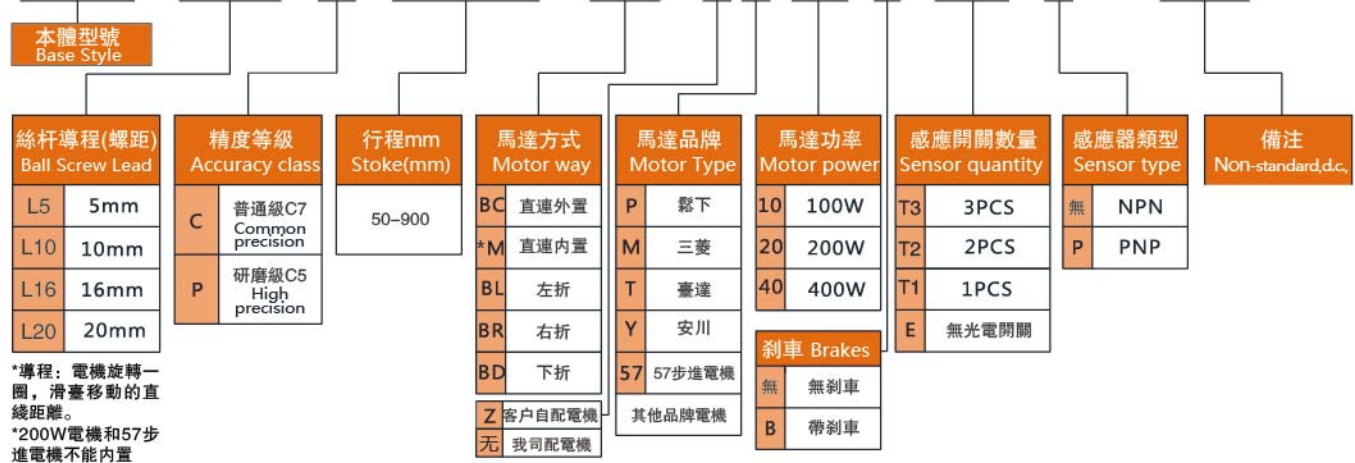

基本型號 Specification

馬達功率(W) Motor Output(W)	100W/200W(400)				
馬達轉速 Motor Speed(rpm/mim)	3000				
滾珠絲桿導程-螺距(mm) Belt Lead(mm)	5	10	16	20	
最高速度(mm/s) Maximum Payload(mm/s)	250	500	800	1000	
最大負載 Rated load(kg)	水平使用 Horizontal	25/30	20/25	18/22	15/17
	垂直使用 Vertical	8/10	7/9	5/8	3/5
額定推力 Rated thrust(n)	341/680	170/340	85/170	42/84	
行程範圍 Range of travel(mm)	50-900MM/50行程遞增				
絲杆外徑 Screw diameter(mm)	Ø16				
重複位置精度 Repeatability(mm)	C7(C)	±0.01			
	C5(P)	±0.006			
導軌規格 Guide specification	9.5X42				
聯軸器 coupling	8X10-100W/10X11(14)-200W*				
感應器 sensor	EE-SX674(NPN)				

*馬達加減速度時間為0.2S
motor speed is 0.2S.

使用鬆下200W電機時聯軸器為10X11，其他品牌為10X14。

*如有特殊行程請先與技術人員聯系
in case special stroke please contact technical services.

傳感器接綫圖 Sensor Wiring diagram

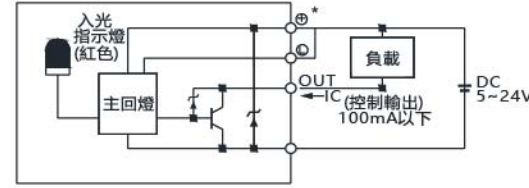

速度與行程 Speed and stroke

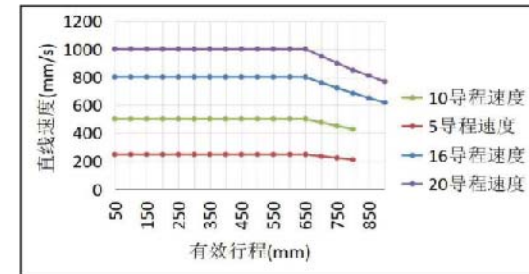

*行程超過650時，絲杆旋轉會產生共振，此時請將速度調低。

When the stroke is more than 500, the rotation of the screw will cause resonance, and then the speed will be lowered.

安裝示意圖 Installation Instrations&Dimentions

安裝方法一：

安裝螺絲從下往上安裝

*注意鎖緊螺絲裝入滑臺的長度不得超過10mm，否則會與內部干涉。

method 1

fix the screw from bottom to up direction

Note that the length of the locking screw installed in the slide shall not exceed 10mm, otherwise it will interfere with the internal.

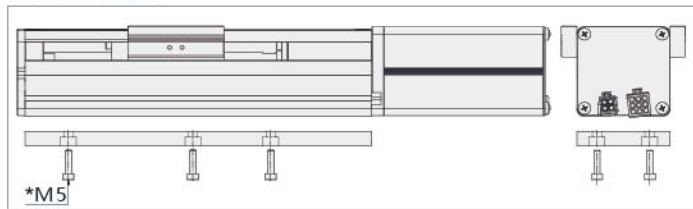

安裝方法二：

打開滑臺上蓋，安裝螺絲從上往下安裝。

method 2:

open the cover, fix the screw from up to bottom

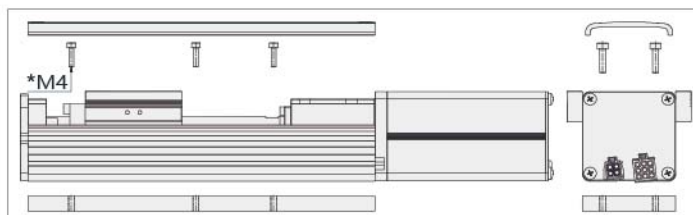

靜態力矩表 Static torque gauge

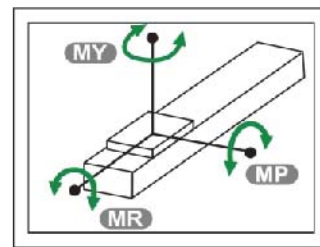

MY	80 (N.M)
MP	90 (N.M)
MR	85 (N.M)

馬達直連外置-BC Motor Exposed

有效行程: 119.5, 84.5

安裝方法一: 安裝螺絲從下往上安裝。*注意鎖緊螺絲裝入滑臺的長度不得超過10mm，否則會與內部干涉。

安裝方法二: 打開滑臺上蓋，安裝螺絲從上往下安裝。

有效行程	50	100	150	200	250	300	350	400	450	500	550	600	650	700	750	800	850	900
L	254	304	354	404	454	504	554	604	654	704	754	804	854	904	954	1004	1054	1104
A	0	50	100	50	100	50	100	50	100	50	100	50	100	50	100	50	100	50
M	0	1	1	2	2	3	3	4	4	5	5	6	6	7	7	8	8	9
N	6	8	8	10	10	12	12	14	14	16	16	18	18	20	20	22	22	24
KG	3	3.3	3.7	4	4.4	4.7	5.1	5.4	5.8	6.1	6.5	6.8	7.2	7.5	7.9	8.2	8.6	9

注：以上不含電機重量。Note: Not including motor weight.
如有特殊行程請先與技術人員聯系。in case special stroke please contact technical services.

馬達直連內置-M Motor built-in

有效行程: 119.5, 84.5

安裝方法一: 安裝螺絲從下往上安裝。*注意鎖緊螺絲裝入滑臺的長度不得超過10mm，否則會與內部干涉。

安裝方法二: 打開滑臺上蓋，安裝螺絲從上往下安裝。

有效行程	50	100	150	200	250	300	350	400	450	500	550	600	650	700	750	800	850	900
L	254	304	354	404	454	504	554	604	654	704	754	804	854	904	954	1004	1054	1104
A	0	50	100	50	100	50	100	50	100	50	100	50	100	50	100	50	100	50
M	0	1	1	2	2	3	3	4	4	5	5	6	6	7	7	8	8	9
N	6	8	8	10	10	12	12	14	14	16	16	18	18	20	20	22	22	24
KG	3.2	3.5	3.9	4.2	4.6	4.9	5.3	5.6	6	6.3	6.7	7	7.4	7.7	7.9	8.4	8.6	9.2

注：以上不含電機重量。Note: Not including motor weight.
如有特殊行程請先與技術人員聯系。in case special stroke please contact technical services.

馬達左折-BL Motor Left Side

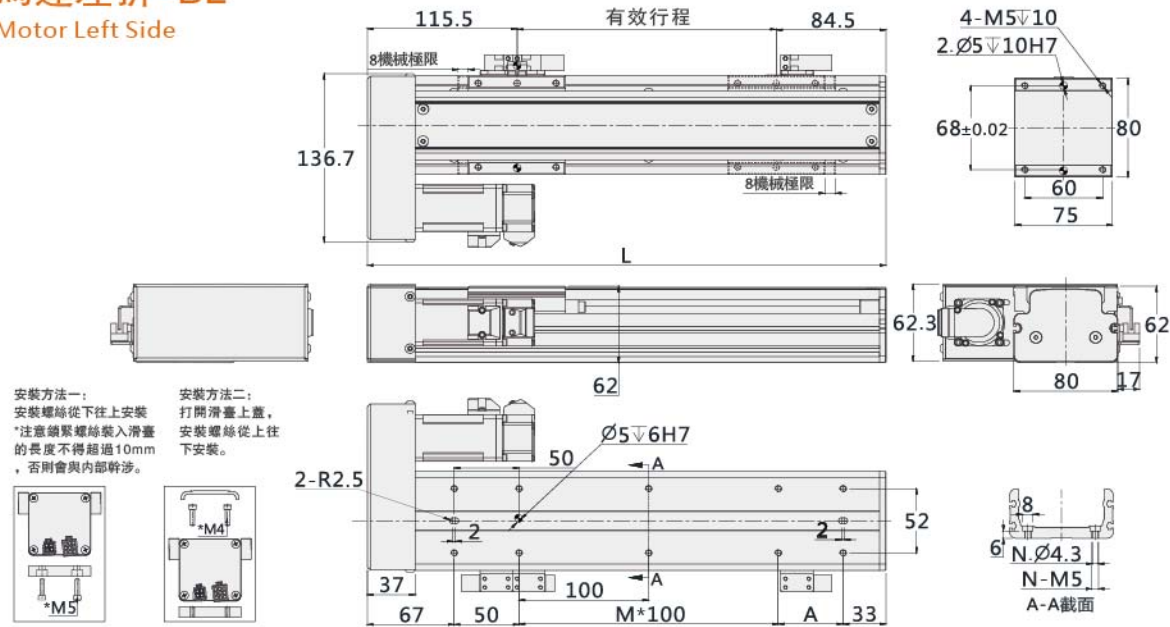

有效行程	50	100	150	200	250	300	350	400	450	500	550	600	650	700	750	800	850	900
L	250	300	350	400	450	500	550	600	650	700	750	800	850	900	950	1000	1050	1100
A	0	50	100	50	100	50	100	50	100	50	100	50	100	50	100	50	100	50
M	0	1	1	2	2	3	3	4	4	5	5	6	6	7	7	8	8	9
N	6	8	8	10	10	12	12	14	14	16	16	18	18	20	20	22	22	24
KG	3.5	3.8	4.2	4.5	4.9	5.2	5.6	5.9	6.3	6.6	7	7.3	7.7	8	8.3	8.7	9	9.5

注：以上不含電機重量。Note: Not including motor weight.
如有特殊行程請先與技術人員聯系。in case special stroke please contact technical services.

馬達下折-BD Motor Bottom Side

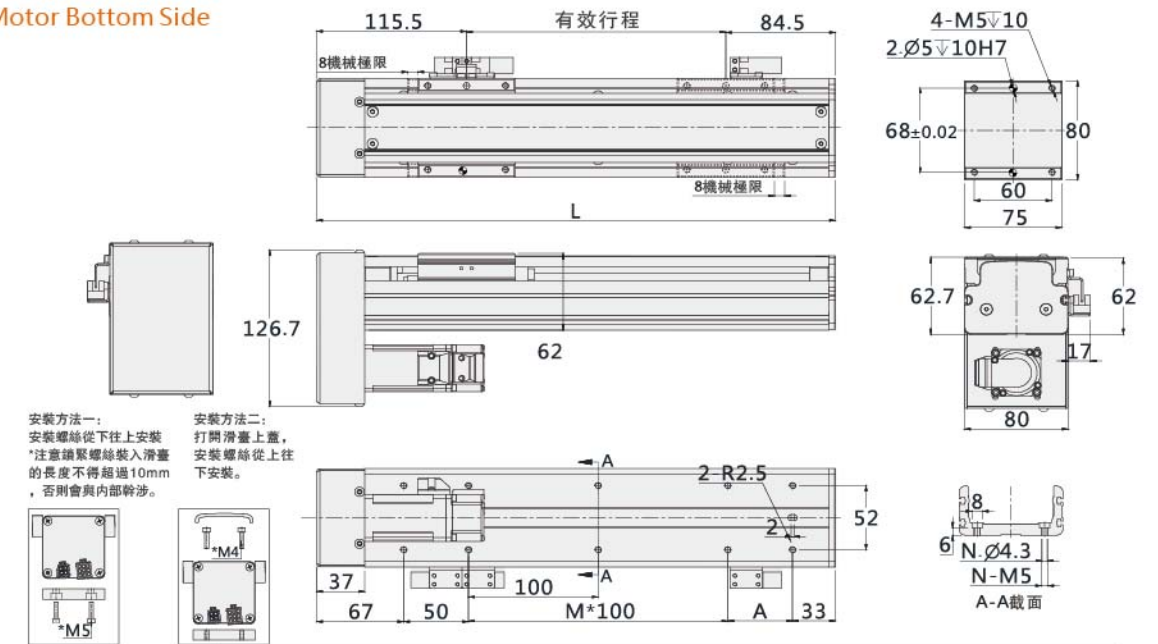

有效行程	50	100	150	200	250	300	350	400	450	500	550	600	650	700	750	800	850	900
L	250	300	350	400	450	500	550	600	650	700	750	800	850	900	950	1000	1050	1100
A	0	50	100	50	100	50	100	50	100	50	100	50	100	50	100	50	100	50
M	0	1	1	2	2	3	3	4	4	5	5	6	6	7	7	8	8	9
N	6	8	8	10	10	12	12	14	14	16	16	18	18	20	20	22	22	24
KG	3.7	4	4.4	4.7	5.1	5.4	5.8	6.1	6.5	6.8	7.2	7.5	7.9	8.2	8.5	8.9	9.2	9.7

注：以上不含電機重量。Note: Not including motor weight.
如有特殊行程請先與技術人員聯系。in case special stroke please contact technical services.

馬達右折-BR Motor Right Side

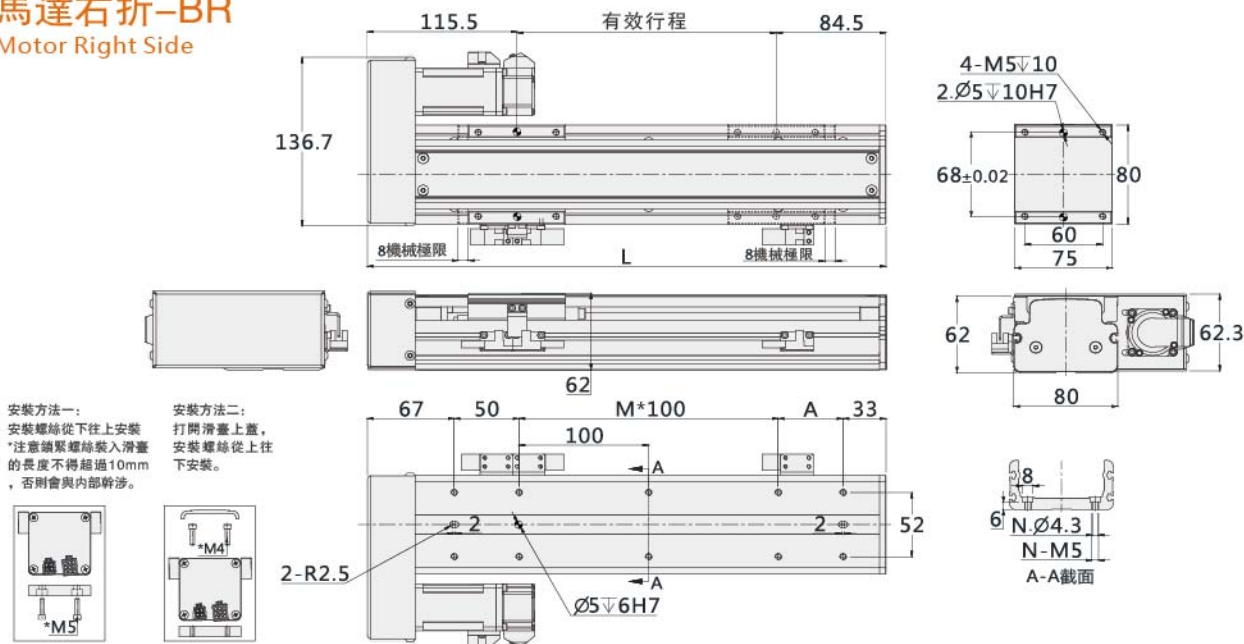

有效行程	50	100	150	200	250	300	350	400	450	500	550	600	650	700	750	800	850	900
L	250	300	350	400	450	500	550	600	650	700	750	800	850	900	950	1000	1050	1100
A	0	50	100	50	100	50	100	50	100	50	100	50	100	50	100	50	100	50
M	0	1	1	2	2	3	3	4	4	5	5	6	6	7	7	8	8	9
N	6	8	8	10	10	12	12	14	14	16	16	18	18	20	20	22	22	24
KG	3.5	3.8	4.2	4.5	4.9	5.2	5.6	5.9	6.3	6.6	7	7.3	7.7	8	8.3	8.7	9	9.5

注：以上不含電機重量。Note: Not including motor weight.
如有特殊行程請先與技術人員聯系。in case special stroke please contact technical services.

標準型滾珠絲杆-LEH10

STANDARD BALL SCREW SLIDE



馬達安裝方式 Motor direction

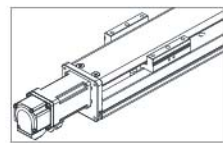

馬達直連外置-BC
Motor Exposed

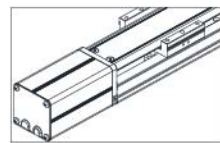

馬達直連內置-M
Motor built-in

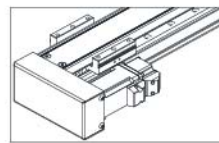

馬達左折-BL
Motor Left Side

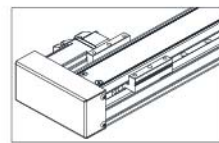

馬達右折-BR
Motor Right Side

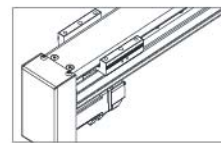

馬達下折-BD
Motor Bottom Side

型號表示方式 Guide for Model Selection

LEH10-L10-C-S100-BC-ZP20B-T3 _ - 001

本體型號 Base Style		絲杆導程(螺距) Ball Screw Lead	精度等級 Accuracy class	行程mm Stroke(mm)	馬達方式 Motor way	馬達品牌 Motor Type	馬達功率 Motor power	感應開關數量 Sensor quantity	感應器類型 Sensor type	備註 Non-standard, d.c.
L5	5mm	C 普通級C7 Common precision	50-1100	BC	P 露下	20	200W	T3	3PCS	無 NPN
L10	10mm			M	M 三菱	40	400W	T2	2PCS	
L20	20mm			BL	T 臺達	剎車 Brakes		T1	1PCS	
L32	32mm			BR	Y 安川	無	無剎車	E	無光電開關	
					BD	57 57步進電機	B	帶剎車		
					Z	客戶自配電機				
					无	我司配電機				

*導程：電機旋轉一圈，滑臺移動的直線距離。

基本型號 Specification

馬達功率(W) Motor Output(W)	200W(400W)			
馬達轉速 Motor Speed(rpm/mim)	*3000			
滾珠絲杆導程-螺距(mm) Belt Lead(mm)	5	10	20	32
最高速度(mm/s) Maximum Payload(mm/s)	250	500	1000	1600
額大負載 Rated load(kg)	水平使用Horizontal	50	40	20
	垂直使用Vertical	15	12	6
額定推力 Rated thrust(n)	694	341	174	107
行程範圍 Range of travel(mm)	50-1100MM/50行程遞增			
絲杆外徑 Screw diameter(mm)	ø16			
重複位置精度 Repeatability(mm)	C7(C)	±0.01		
	C5(P)	±0.006		
導軌規格 Guide specification	W15XH12-2支			
聯軸器 coupling	10X14(11)*			
感應器 sensor	EE-SX674(NPN)			

*馬達加減速度時間為0.2S
motor speed is 0.2S.

使用鬆下200W電機時聯軸器為10X11，其他品牌為10X14。

*如有特殊行程請先與技術人員聯系

in case special stroke please contact technical services.

安裝示意圖 Installation Instratons&Dimentions

安裝方法一：

安裝螺絲從下往上安裝

*注意鎖緊螺絲裝入滑臺的長度不得超過11mm，否則會與內部干涉。

method 1

fix the screw from bottom to up direction

Note that the length of the locking screw installed in the slide shall not exceed 10mm, otherwise it will interfere with the internal.

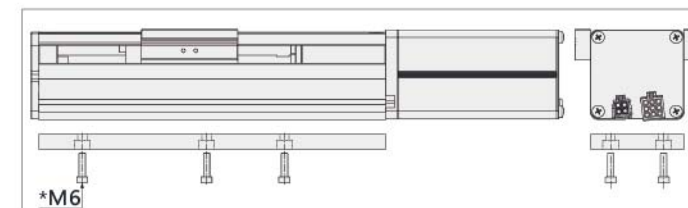

安裝方法二：

打開滑臺上蓋，安裝螺絲從上往下安裝。

method 2:

open the cover, fix the screw from up to bottom

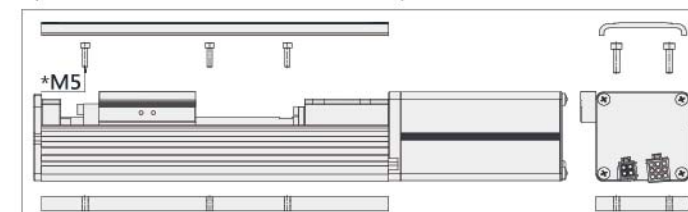

傳感器接線圖 Sensor Wiring diagram

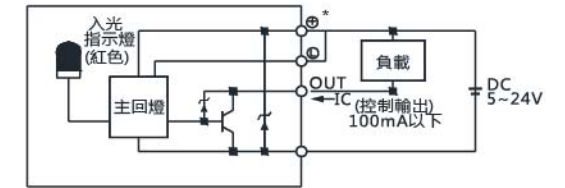

速度與行程 Speed and stroke

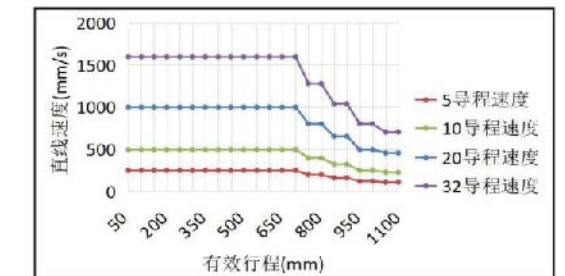

*行程超過750時，絲杆旋轉會產生共振，此時請將速度調低。

When the stroke is more than 500, the rotation of the screw will cause resonance, and then the speed will be lowered.

靜態力矩表 Static torque gauge

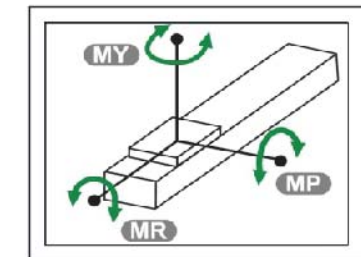

MY	160 (N.M)
MP	160 (N.M)
MR	140 (N.M)

馬達直連外置-BC Motor Exposed

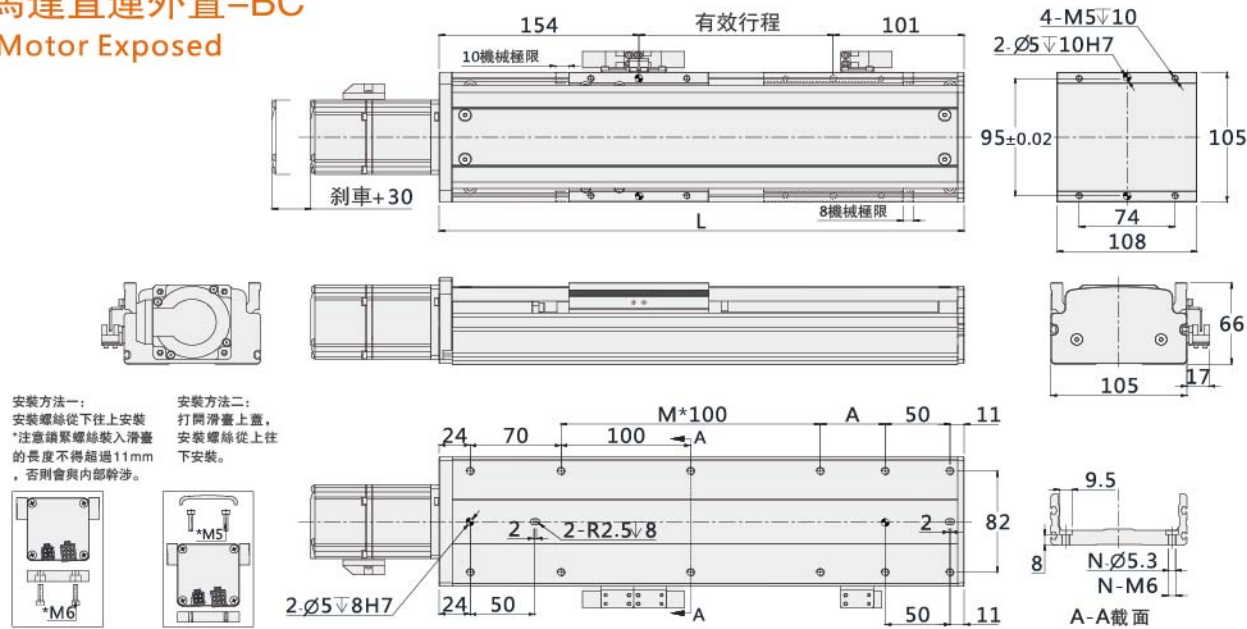

安裝方法一：
安裝螺絲從下往上安裝
*注意鎖緊螺絲裝入滑臺
的長度不得超過11mm
，否則會與內部干涉。

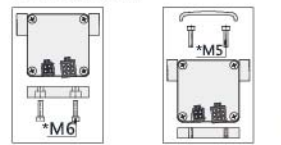

有效行程	50	100	150	200	250	300	350	400	450	500	550	600	650	700	750	800	850	900	950	1000	1050	1100
L	305	355	405	455	505	555	605	655	705	755	805	855	905	955	1005	1055	1105	1155	1205	1255	1305	1355
A	50	100	50	100	50	100	50	100	50	100	50	100	50	100	50	100	50	100	50	100	50	100
M	1	1	2	2	3	3	4	4	5	5	6	6	7	7	8	8	9	9	10	10	11	11
N	10	10	12	12	14	14	16	16	18	18	20	20	22	22	24	24	26	26	28	28	30	30
KG	3.8	4.2	4.6	5	5.5	5.9	6.3	6.7	7.1	7.5	7.9	8.5	8.9	9.4	9.8	10.2	10.6	11	11.4	11.8	12.2	12.6

注：以上不含電機重量。Note: Not including motor weight.
如有特殊行程請先與技術人員聯繫。in case special stroke please contact technical services.

馬達左折-BL Motor Left Side

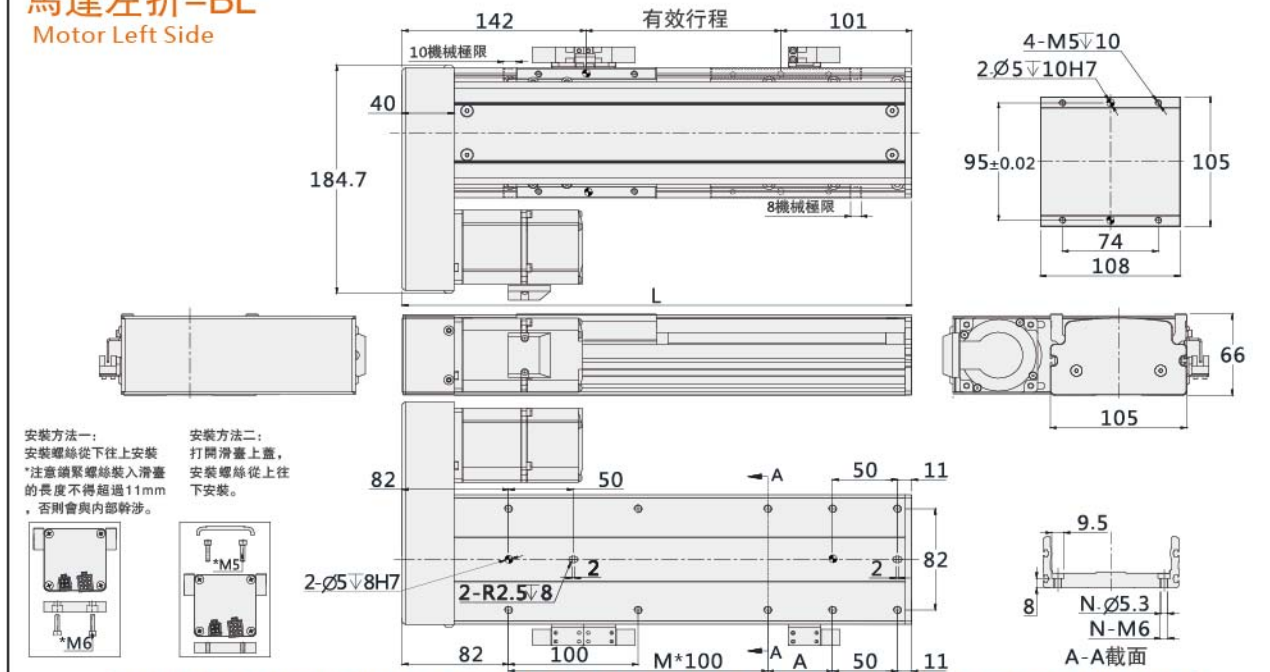

安裝方法一：
安裝螺絲從下往上安裝
*注意鎖緊螺絲裝入滑臺
的長度不得超過11mm
，否則會與內部干涉。

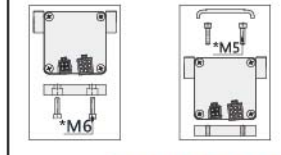

有效行程	50	100	150	200	250	300	350	400	450	500	550	600	650	700	750	800	850	900	950	1000	1050	1100
L	293	343	393	443	493	543	593	643	693	743	793	843	893	943	993	1043	1093	1143	1193	1243	1293	1343
A	50	100	50	100	50	100	50	100	50	100	50	100	50	100	50	100	50	100	50	100	50	100
M	1	1	2	2	3	3	4	4	5	5	6	6	7	7	8	8	9	9	10	10	11	11
N	8	8	10	10	12	12	14	14	16	16	18	18	20	20	22	22	24	24	26	26	28	28
KG	4.4	4.9	5.2	5.6	6	6.4	6.8	7.2	7.6	8	8.4	8.8	9.4	9.8	10.4	10.8	11.2	11.6	12	12.4	12.8	13.2

注：以上不含電機重量。Note: Not including motor weight.
如有特殊行程請先與技術人員聯繫。in case special stroke please contact technical services.

馬達直連內置-M Motor built-in

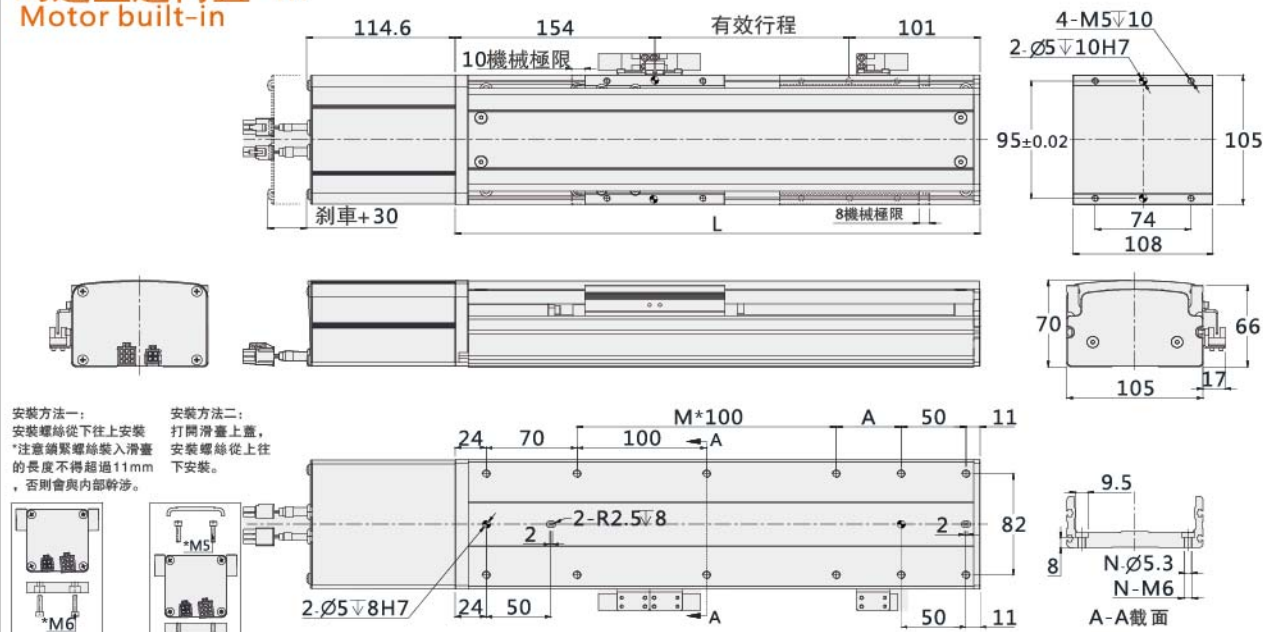

安裝方法一：
安裝螺絲從下往上安裝
*注意鎖緊螺絲裝入滑臺
的長度不得超過11mm
，否則會與內部干涉。

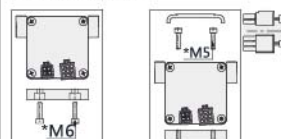

有效行程	50	100	150	200	250	300	350	400	450	500	550	600	650	700	750	800	850	900	950	1000	1050	1100
L	305	355	405	455	505	555	605	655	705	755	805	855	905	955	1005	1055	1105	1155	1205	1255	1305	1355
A	50	100	50	100	50	100	50	100	50	100	50	100	50	100	50	100	50	100	50	100	50	100
M	1	1	2	2	3	3	4	4	5	5	6	6	7	7	8	8	9	9	10	10	11	11
N	10	10	12	12	14	14	16	16	18	18	20	20	22	22	24	24	26	26	28	28	30	30
KG	4.2	4.6	5	5.4	5.8	6.2	6.6	7	7.4	7.8	8.2	8.6	9.2	9.6	10.2	10.6	11	11.4	11.8	12.2	12.6	13

注：以上不含電機重量。Note: Not including motor weight.
如有特殊行程請先與技術人員聯繫。in case special stroke please contact technical services.

馬達右折-BR Motor Right Side

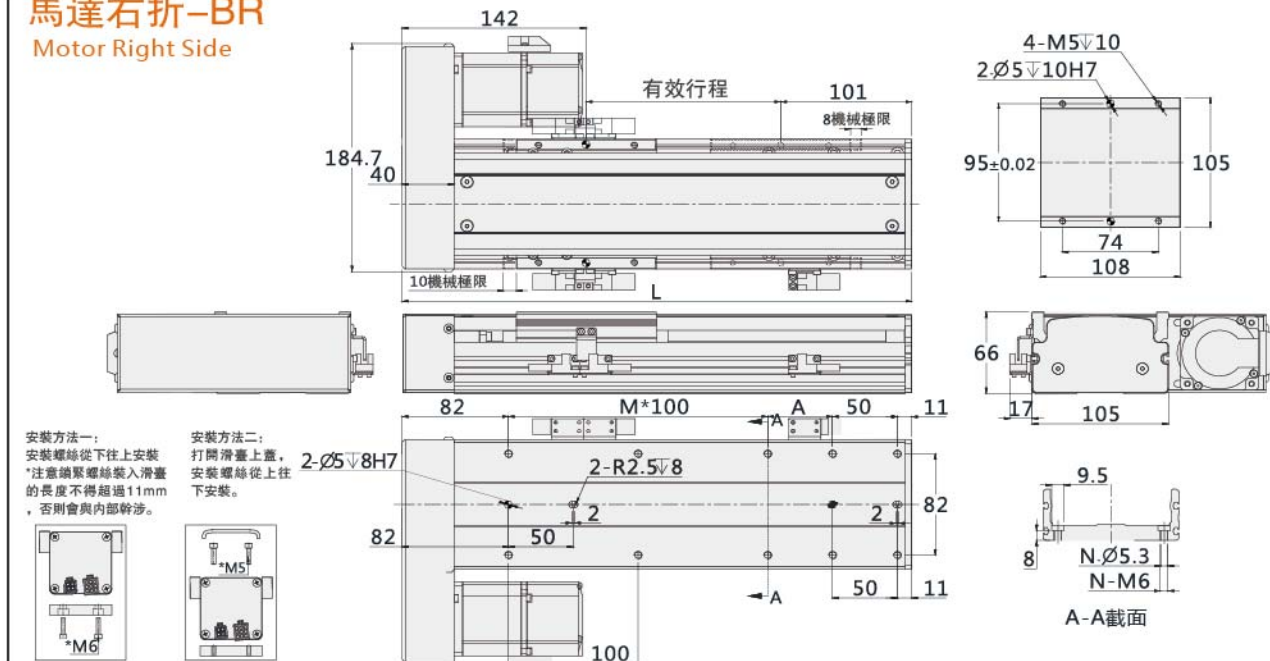

安裝方法一：
安裝螺絲從下往上安裝
*注意鎖緊螺絲裝入滑臺
的長度不得超過11mm
，否則會與內部干涉。

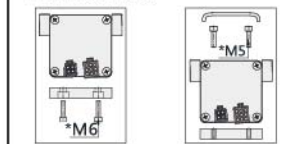

有效行程	50	100	150	200	250	300	350	400	450	500	550	600	650	700	750	800	850	900	950	1000	1050	1100
L	293	343	393	443	493	543	593	643	693	743	793	843	893	943	993	1043	1093	1143	1193	1243	1293	1343
A	50	100	50	100	50	100	50	100	50	100	50	100	50	100	50	100	50	100	50	100	50	100
M	1	1	2	2	3	3	4	4	5	5	6	6	7	7	8	8	9	9	10	10	11	11
N	8	8	10	10	12	12	14	14	16	16	18	18	20	20	22	22	24	24	26	26	28	28
KG	4.4	4.9	5.2	5.6	6	6.4	6.8	7.2	7.6	8	8.4	8.8	9.4	9.8	10.4	10.8	11.2	11.6	12	12.4	12.8	13.2

注：以上不含電機重量。Note: Not including motor weight.
如有特殊行程請先與技術人員聯繫。in case special stroke please contact technical services.

馬達下折-BD
Motor Bottom Side

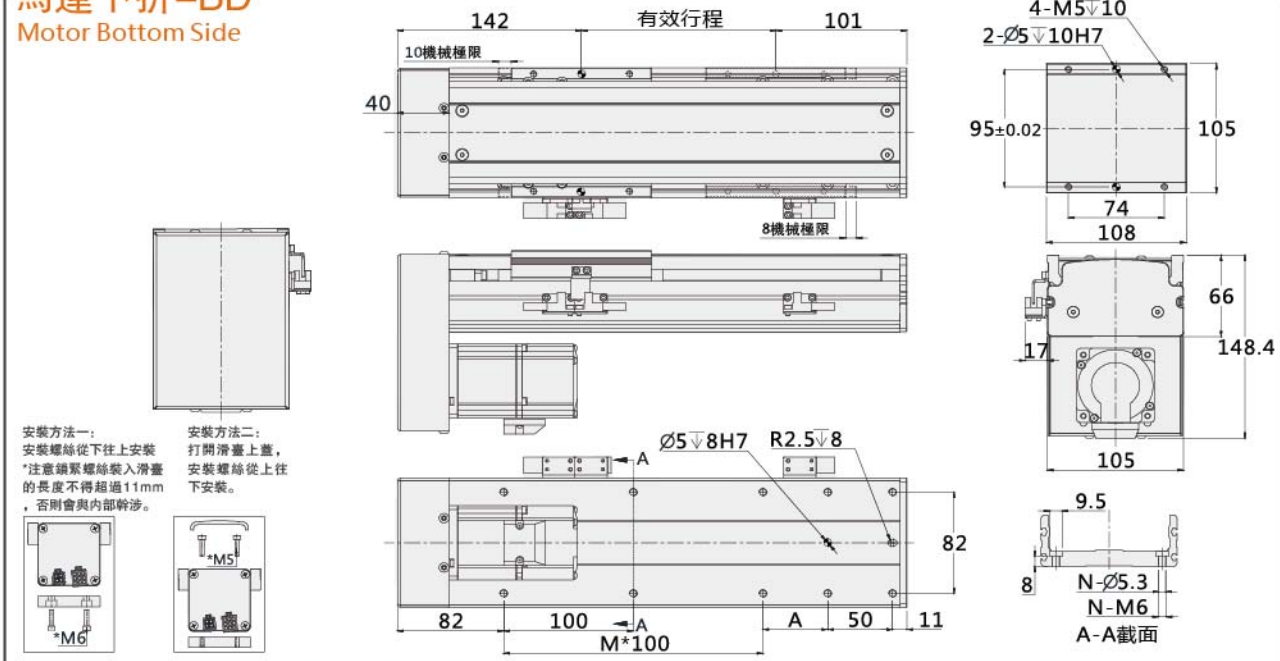

有效行程	50	100	150	200	250	300	350	400	450	500	550	600	650	700	750	800	850	900	950	1000	1050	1100
L	293	343	393	443	493	543	593	643	693	743	793	843	893	943	993	1043	1093	1143	1193	1243	1293	1343
A	50	100	50	100	50	100	50	100	50	100	50	100	50	100	50	100	50	100	50	100	50	100
M	1	1	2	2	3	3	4	4	5	5	6	6	7	7	8	8	9	9	10	10	11	11
N	8	8	10	10	12	12	14	14	16	16	18	18	20	20	22	22	24	24	26	26	28	28
KG	4.6	5.1	5.4	5.8	6.2	6.6	7	7.4	7.8	8.2	8.6	9	9.6	10	10.6	11	11.4	11.8	12.2	12.6	13	13.4

注：以上不含電機重量。Note: Not including motor weight.
如有特殊行程請先與技術人員聯繫。in case special stroke please contact technical services.



馬達安裝方式 Motor direction

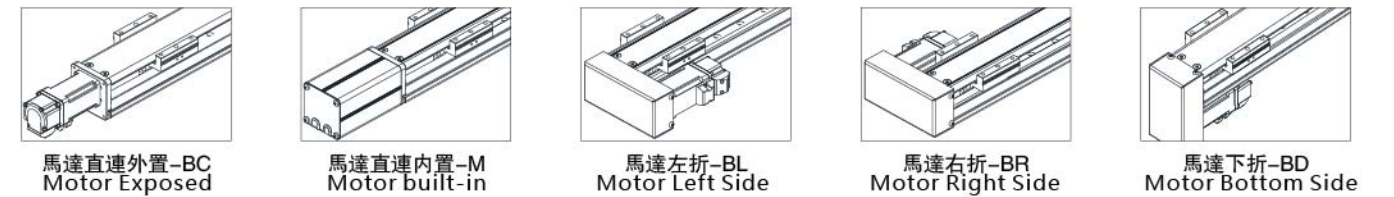

型號表示方式 Guide for Model Selection

LEH13-L10-C-S100-BC-ZP40B-T3 _ - 001



基本型號 Specification

馬達功率(W) Motor Output(W)	400W				
馬達轉速 Motor Speed(rpm/mim)	*3000				
滾珠絲桿導程-螺距(mm) Belt Lead(mm)	5	10	20	32	
最高速度(mm/s) Maximum Payload(mm/s)	250	500	1000	1600	
最大負載 Rated load(kg)	水平使用 Horizontal	110	88	40	30
	垂直使用 Vertical	33	25	10	8
額定推力 Rated thrust(n)	1388	694	347	218	
行程範圍 Range of travel(mm)	50-1300MM/50行程遞增				
絲杆外徑 Screw diameter(mm)	∅16(∅20)		∅16		
重複位置精度 Repeatability(mm)	C7(C)	±0.01			
	C5(P)	±0.006			
導軌規格 Guide specification	W15XH12-2支				
聯軸器 coupling	10X14(11)*				
感應器 sensor	EE-SX674(NPN)				

*馬達加減速度時間為0.2S
motor speed is 0.2S.

*標配絲杆∅16，也可定制∅20

*使用鬆下200W電機時聯軸器為10X11，其他品牌為10X14。

*如有特殊行程請先與技術人員聯系
in case special stroke please contact technical services.

傳感器接線圖 Sensor Wiring diagram

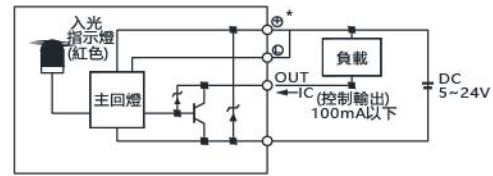

速度與行程 Speed and stroke

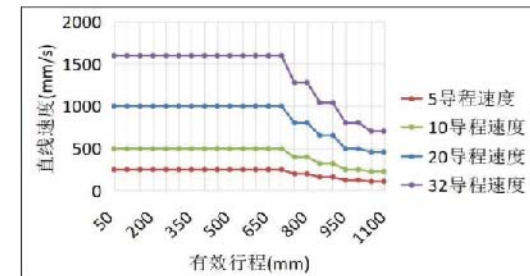

*行程超過750時，絲杆旋轉會產生共振，此時請將速度調低。

When the stroke is more than 750, the rotation of the screw will cause resonance, and then the speed will be lowered.

安裝示意圖 Installation Instrations&Dimentions

安裝方法一：
安裝螺絲從下往上安裝
method 1:
fix the screw from up to bottom

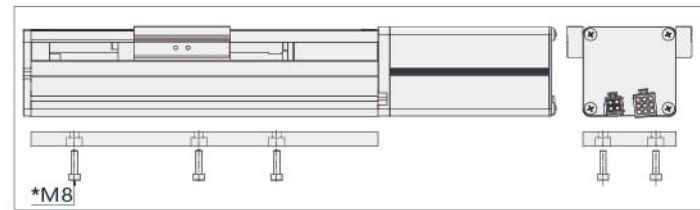

安裝方法二：
打開滑臺上蓋，安裝螺絲從上往下安裝。
method 2:
open the cover, fix the screw from up to bottom

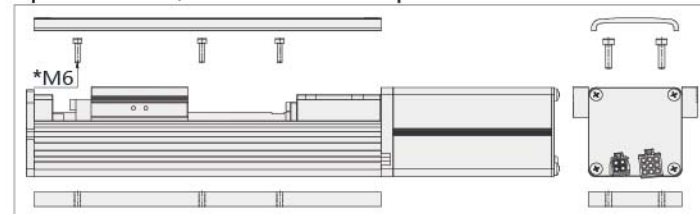

靜態力矩表 Static torque gauge

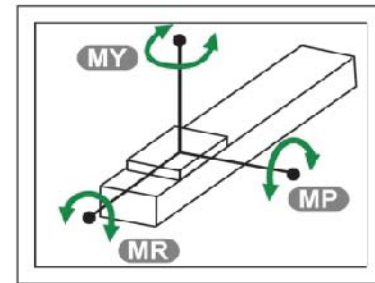

MY	551 (N.M)
MP	552 (N.M)
MR	485 (N.M)

馬達直連外置-BC Motor Exposed

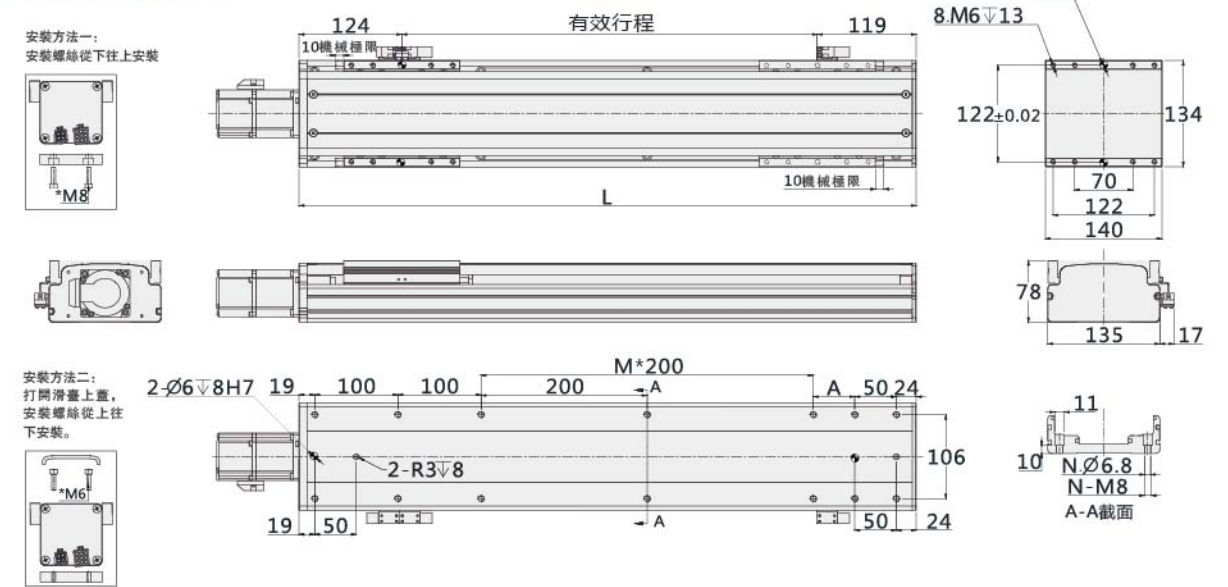

有效行程	50	100	150	200	250	300	350	400	450	500	550	600	650	700	750	800	850	900	950	1000	1050	1100
L	293	343	393	443	493	543	593	643	693	743	793	843	893	943	993	1043	1093	1143	1193	1243	1293	1343
A	0	0	0	0	0	50	100	150	200	50	100	150	200	50	100	150	200	50	100	150	200	50
M	0	0	0	0	0	1	1	1	1	2	2	2	2	3	3	3	3	4	4	4	4	5
N	8	10	10	10	10	12	12	12	12	14	14	14	14	16	16	16	16	18	18	18	18	20
KG	6.2	6.8	7.4	8	8.6	9.2	9.8	10.4	11	11.6	12.2	12.8	13.4	14	14.6	15.2	15.8	16.4	17	17.6	18.2	18.8

注：以上不含電機重量。Note: Not including motor weight.
如有特殊行程請先與技術人員聯系。in case special stroke please contact technical services.

馬達直連內置-M Motor built-in

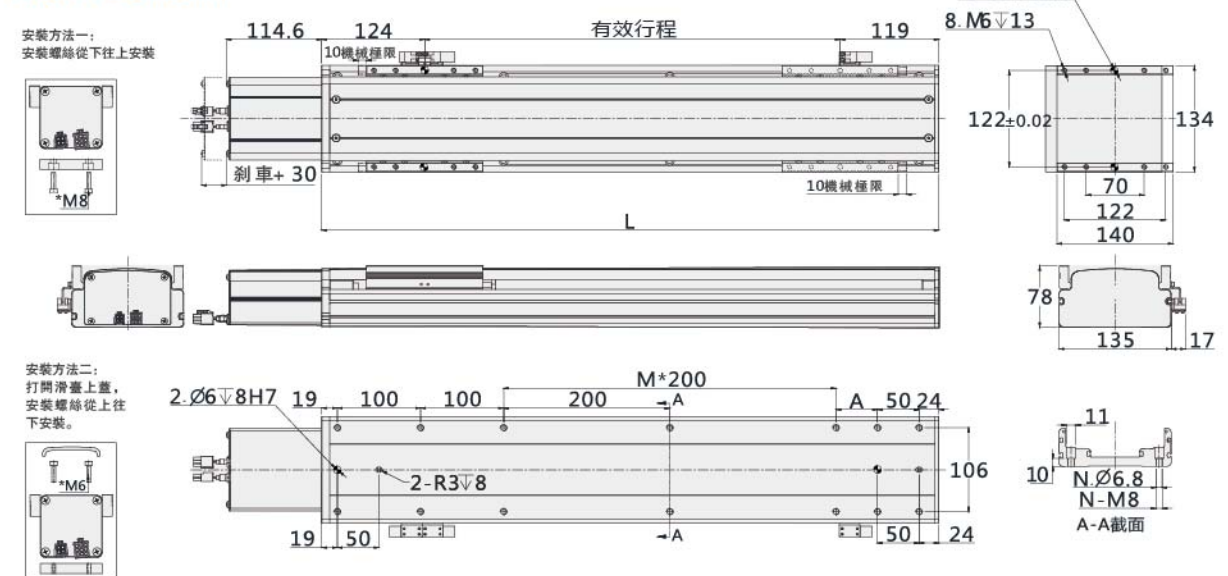

有效行程	50	100	150	200	250	300	350	400	450	500	550	600	650	700	750	800	850	900	950	1000	1050	1100
L	293	343	393	443	493	543	593	643	693	743	793	843	893	943	993	1043	1093	1143	1193	1243	1293	1343
A	0	0	0	0	0	50	100	150	200	50	100	150	200	50	100	150	200	50	100	150	200	50
M	0	0	0	0	0	1	1	1	1	2	2	2	2	3	3	3	3	4	4	4	4	5
N	8	10	10	10	10	12	12	12	12	14	14	14	14	16	16	16	16	18	18	18	18	20
KG	6.5	7.1	7.7	8.3	8.9	9.5	10.1	10.7	11.3	11.9	12.5	13.1	13.7	14.3	14.9	15.5	16.1	16.7	17.3	17.9	18.5	19.1

注：以上不含電機重量。Note: Not including motor weight.
如有特殊行程請先與技術人員聯系。in case special stroke please contact technical services.

馬達左折-BL Motor Left Side

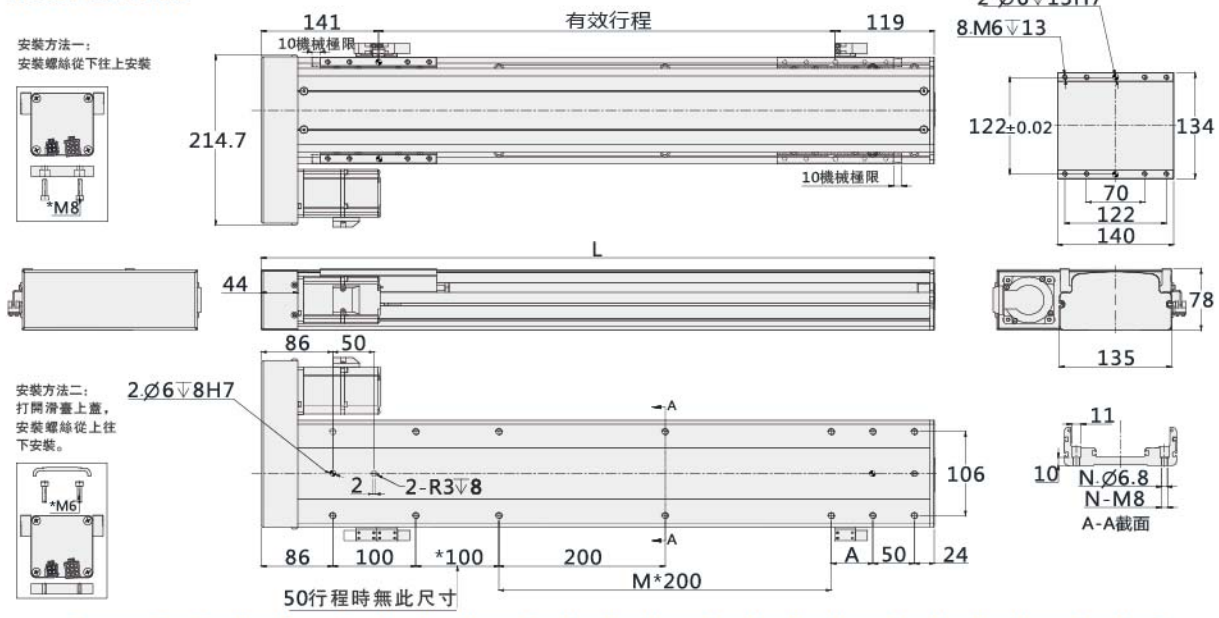

有效行程	50	100	150	200	250	300	350	400	450	500	550	600	650	700	750	800	850	900	950	1000	1050	1100
L	310	360	410	460	510	560	610	660	710	760	810	860	910	960	1010	1060	1110	1160	1210	1260	1310	1360
A	0	0	0	0	0	0	50	100	150	200	50	100	150	200	50	100	150	200	50	100	150	200
M	0	0	0	0	0	0	1	1	1	1	2	2	2	2	3	3	3	3	4	4	4	4
N	8	8	10	10	10	10	12	12	12	12	14	14	14	14	16	16	16	16	18	18	18	18
KG	7.2	7.8	8.4	9	9.6	10.2	10.8	11.4	12	12.6	13.2	13.8	14.4	15	15.6	16.1	16.7	17.3	17.9	18.5	19.1	19.7

注：以上不含電機重量。Note: Not including motor weight.
如有特殊行程請先與技術人員聯繫。in case special stroke please contact technical services.

馬達下折-BD Motor Bottom Side

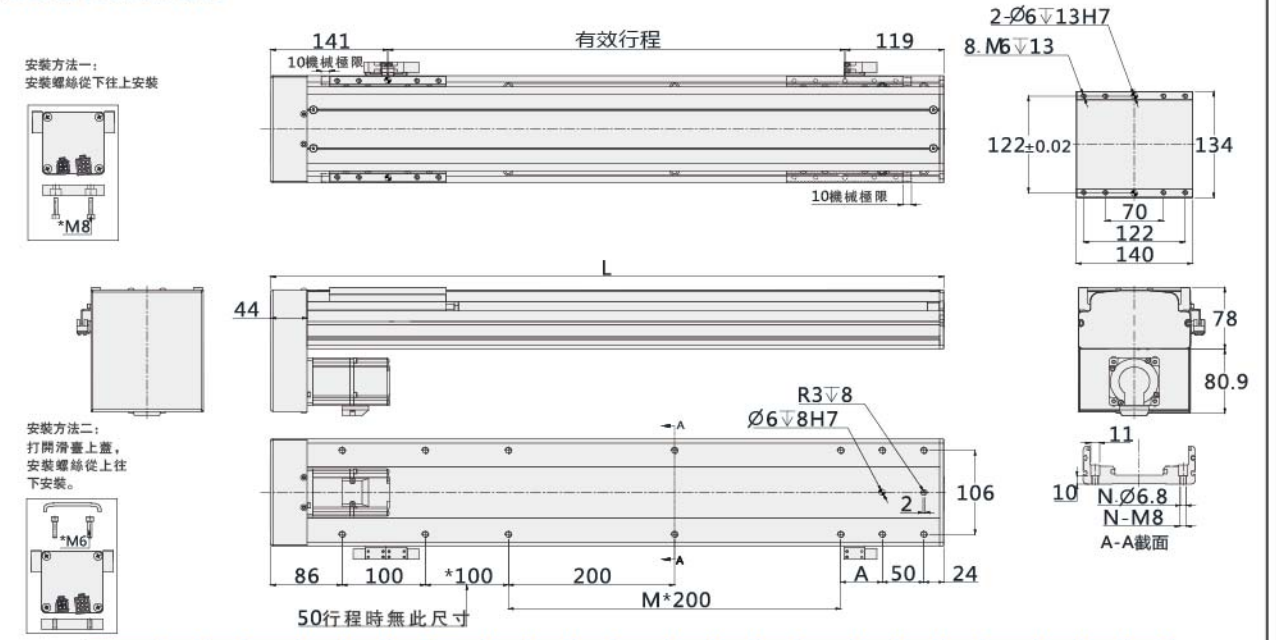

有效行程	50	100	150	200	250	300	350	400	450	500	550	600	650	700	750	800	850	900	950	1000	1050	1100
L	310	360	410	460	510	560	610	660	710	760	810	860	910	960	1010	1060	1110	1160	1210	1260	1310	1360
A	0	0	0	0	0	0	50	100	150	200	50	100	150	200	50	100	150	200	50	100	150	200
M	0	0	0	0	0	0	1	1	1	1	2	2	2	2	3	3	3	3	4	4	4	4
N	8	8	10	10	10	10	12	12	12	12	14	14	14	14	16	16	16	16	18	18	18	18
KG	7.4	8	8.6	9.2	9.8	10.4	11	11.6	12.2	12.8	13.2	14	14.6	15.2	15.8	16.3	16.9	17.5	18.1	18.5	19.3	19.9

注：以上不含電機重量。Note: Not including motor weight.
如有特殊行程請先與技術人員聯繫。in case special stroke please contact technical services.

馬達右折-BR Motor Right Side

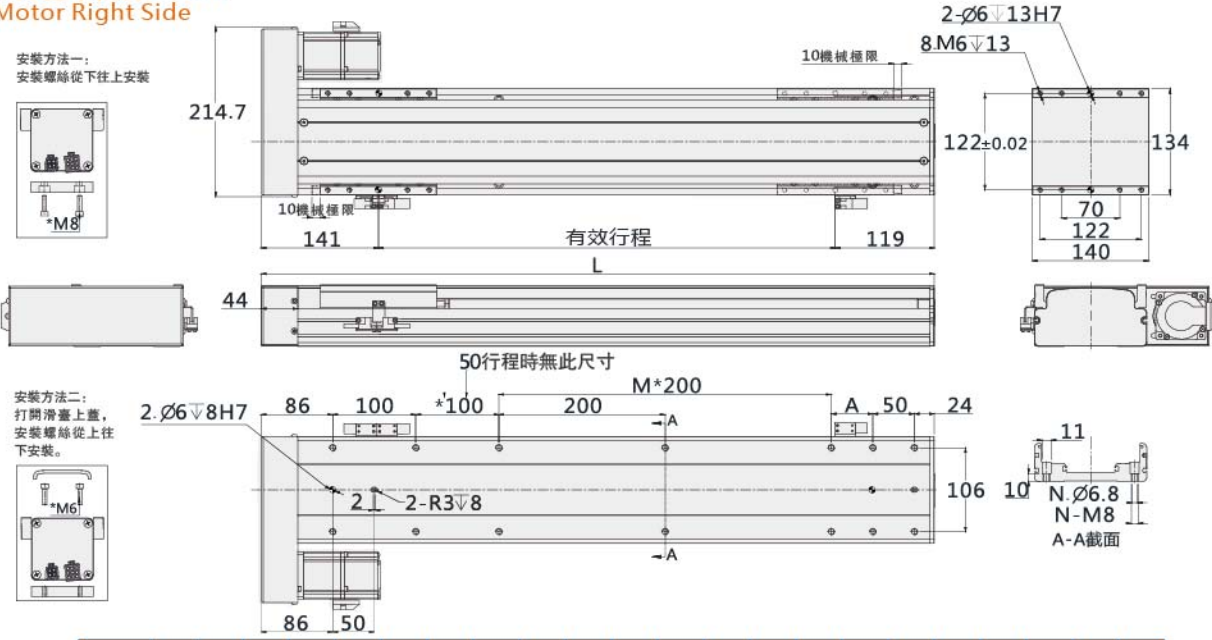

有效行程	50	100	150	200	250	300	350	400	450	500	550	600	650	700	750	800	850	900	950	1000	1050	1100
L	310	360	410	460	510	560	610	660	710	760	810	860	910	960	1010	1060	1110	1160	1210	1260	1310	1360
A	0	0	0	0	0	0	50	100	150	200	50	100	150	200	50	100	150	200	50	100	150	200
M	0	0	0	0	0	0	1	1	1	1	2	2	2	2	3	3	3	3	4	4	4	4
N	8	8	10	10	10	10	12	12	12	12	14	14	14	14	16	16	16	16	18	18	18	18
KG	7.2	7.8	8.4	9	9.6	10.2	10.8	11.4	12	12.6	13.2	13.8	14.4	15	15.6	16.1	16.7	17.3	17.9	18.5	19.1	19.7

注：以上不含電機重量。Note: Not including motor weight.
如有特殊行程請先與技術人員聯繫。in case special stroke please contact technical services.

標準型滾珠絲杆驅動-LEH17

STANDARD BALL SCREW SLIDE



基本型號 Specification

馬達功率(W) Motor Output(W)	400W/750			
馬達轉速(rpm/mim) Motor Speed(rpm/mim)	*3000			
滾珠絲杆導程-螺距(mm) Belt Lead(mm)	5	10	20	40
最高速度(mm/s) Maximum Payload(mm/s)	250	500	1000	2000
最大負載 Rated load(kg)	水平使用 Horizontal	120	110/120	75/83
	垂直使用 Vertical	40/50	30/40	14/25
額定推力 Rated thrust(n)	1388/2553 694/1281 347/640 174/320			
行程範圍 Range of travel(mm)	50-1800MM/50行程遞增			
絲杆外徑 Screw diameter(mm)	* $\phi 20(\phi 25)$			$\phi 20$
重複位置精度 Repeatability(mm)	C7(C)	± 0.01		
	C5(P)	± 0.006		
導軌規格 Guide specification	W20XH15-2支			
聯軸器 coupling	12X14(配400W)/12X19(配750W)			
感應器 sensor	EE-SX674(NPN)			

*馬達加減速度時間為0.2S
motor speed is 0.2S.
*標配絲杆 $\phi 20$,也可定制 $\phi 25$ 。
*如有特殊行程請先與技術人員聯系。
in case special stroke please contact technical services.

傳感器接綫圖 Sensor Wiring diagram

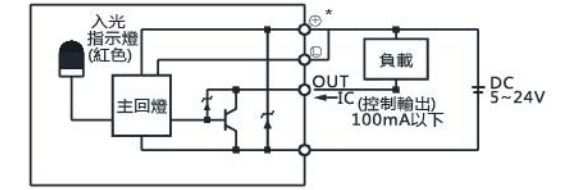

速度與行程 Speed and stroke

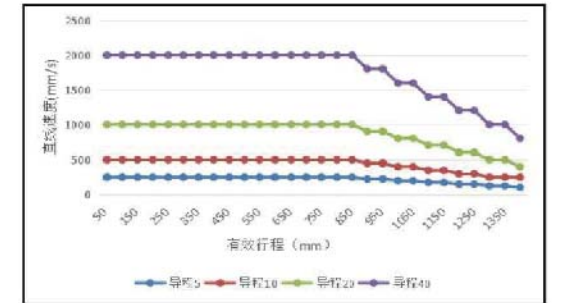

*行程超過850時, 絲杆旋轉會產生共振, 此時請將速度調低。
When the stroke is more than 500, the rotation of the screw will cause resonance, and then the speed will be lowered.

馬達安裝方式 Motor direction

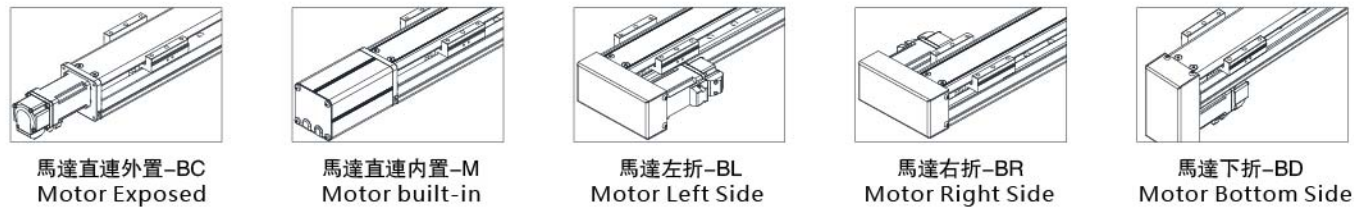

型號表示方式 Guide for Model Selection

LEH17-L10-C-S100-BC-ZP40B-T3--001

本體型號 Base Style	絲杆導程(螺距) Ball Screw Lead	精度等級 Accuracy class	行程mm Stroke(mm)	馬達方式 Motor way	馬達品牌 Motor Type	馬達功率 Motor power	感應開關數量 Sensor quantity	感應器類型 Sensor type	備注 Non-standard, d.c.
L5	5mm	C 普通級C7 Common precision	50-1800	BC 直連外置	P 鬆下	40 400W	T3 3PCS	無 NPN	
	L10								
L20	20mm	P 研磨級C5 High precision		M 直連內置	M 三菱	75 750W	T2 2PCS	P PNP	
	L40								
選配絲杆 $\phi 25$	L2505	5mm		BL 左折	T 臺達	無 無剎車	T1 1PCS	E 無光電開關	
	L2510	10mm							
	L2520	20mm							
	L2540	32mm							
Z 客戶自配電機				BR 右折	Y 安川	無 無剎車			
無 我可配電機				BD 下折	57 57步進電機	B 帶剎車			
					其他品牌電機				

*導程: 電機旋轉一圈, 滑臺移動的直綫距離。

安裝示意圖 Installation Instructions & Dimensions

安裝方法一:
安裝螺絲從下往上安裝
method 1
fix the screw from bottom to up direction

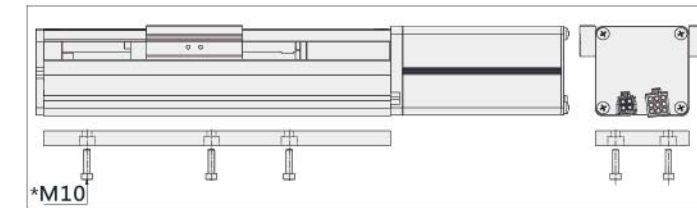

安裝方法二:
打開滑臺上蓋, 安裝螺絲從上往下安裝。
method 2:
open the cover, fix the screw from up to bottom

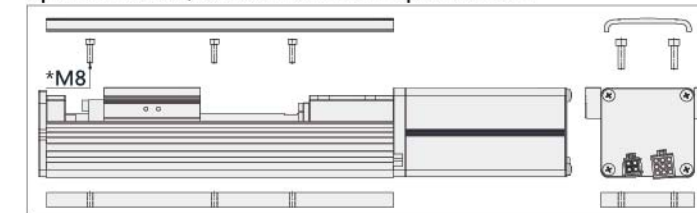

靜態力矩表 Static torque gauge

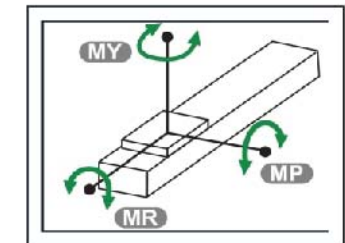

MY	1032 (N.M)
MP	1034 (N.M)
MR	908 (N.M)

馬達直連外置-BC Motor Exposed

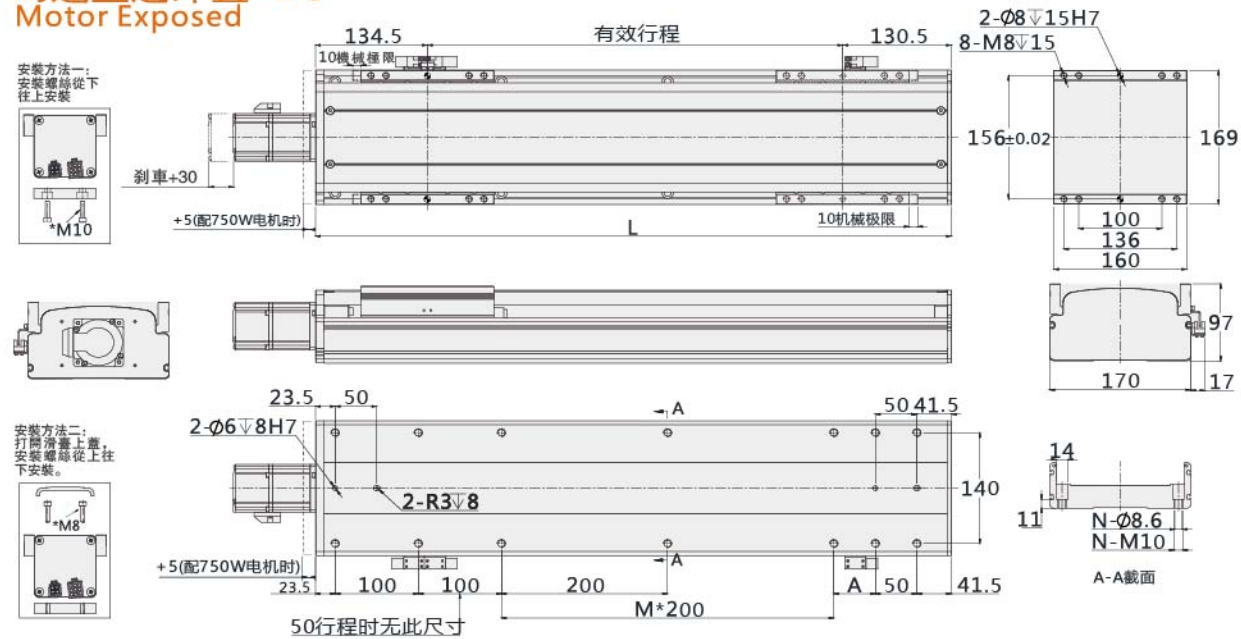

有效行程	50	100	150	200	250	300	350	400	450	500	550	600	650	700	750	800	850	900	950	1000	1050	1100	1150	1200	1250	1300	1350	1400	
L	315	365	415	465	515	565	615	665	715	765	815	865	915	965	1015	1065	1115	1165	1215	1265	1315	1365	1415	1465	1515	1565	1615	1665	
A	0	0	0	0	0	50	100	150	200	50	100	150	200	50	100	150	200	50	100	150	200	50	100	150	200	50	100	150	200
M	0	0	0	0	0	1	1	1	1	2	2	2	2	3	3	3	3	4	4	4	4	5	5	5	5	6	6	6	6
N	8	10	10	10	10	12	12	12	14	14	14	14	14	16	16	16	16	18	18	18	18	20	20	20	20	22	22	22	22
KG	8.8	9.6	10.4	11.1	11.9	12.7	13.5	14.3	15.1	15.9	16.7	17.5	18.3	19	19.8	20.6	21.4	22.2	23	23.8	24.6	25.4	26.2	27	27.8	28.5	29.3	30	

注：以上不含電機重量。Note: Not including motor weight.
如有特殊行程請先與技術人員聯繫。in case special stroke please contact technical services.

馬達左折-BL Motor Left Side

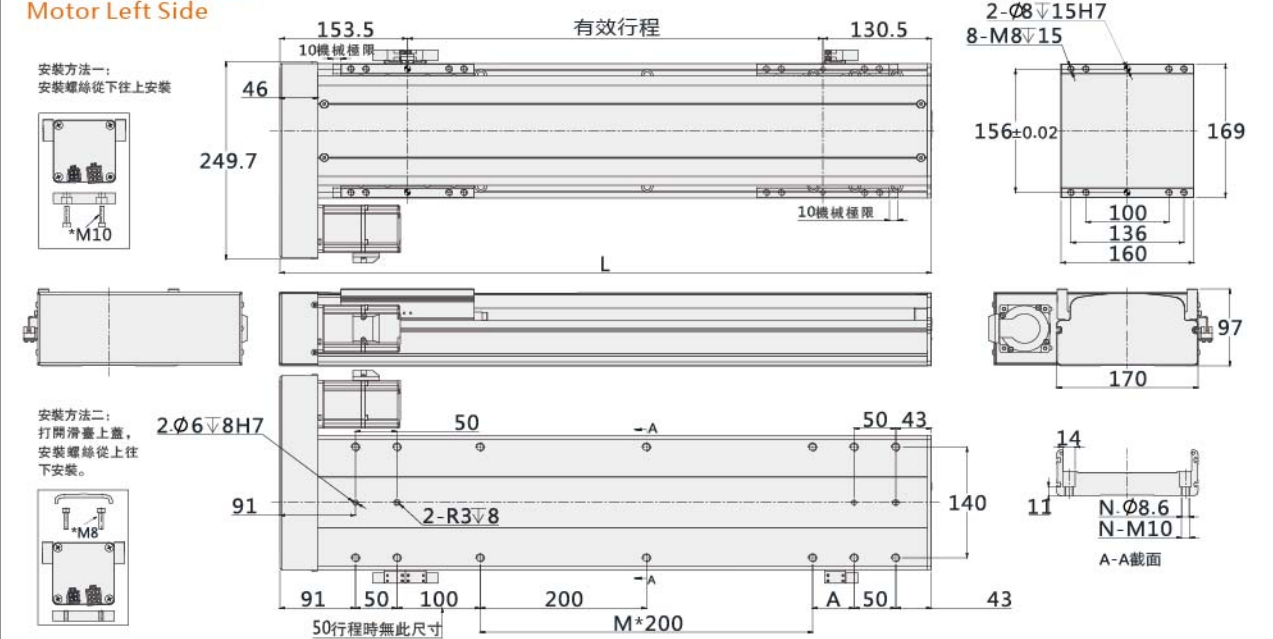

有效行程	50	100	150	200	250	300	350	400	450	500	550	600	650	700	750	800	850	900	950	1000	1050	1100	1150	1200	1250	1300	1350	1400	
L	334	384	434	484	534	584	634	684	734	784	834	884	934	984	1034	1084	1134	1184	1234	1284	1334	1384	1434	1484	1534	1584	1634	1684	
A	0	0	0	0	0	50	100	150	200	50	100	150	200	50	100	150	200	50	100	150	200	50	100	150	200	50	100	150	200
M	0	0	0	0	0	1	1	1	1	2	2	2	2	3	3	3	3	4	4	4	4	5	5	5	5	6	6	6	6
N	8	10	10	10	10	12	12	12	14	14	14	14	14	16	16	16	16	18	18	18	18	20	20	20	20	22	22	22	22
KG	10	10.7	11.5	12.2	13	13.8	14.9	15.4	16.2	17	17.8	18.6	19.4	20.1	20.9	21.7	22.5	23.3	24.1	24.9	25.7	26.5	27.3	28.1	28.9	29.6	30.5	31.2	

注：以上不含電機重量。Note: Not including motor weight.
如有特殊行程請先與技術人員聯繫。in case special stroke please contact technical services.

馬達直連內置-M Motor built-in

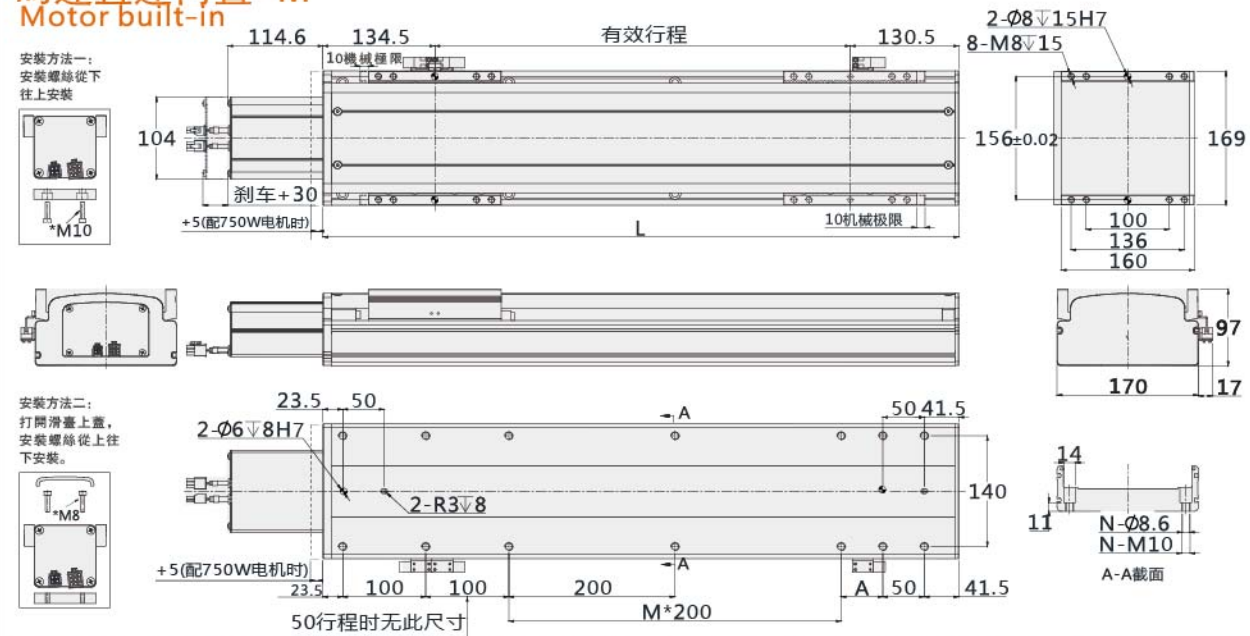

有效行程	50	100	150	200	250	300	350	400	450	500	550	600	650	700	750	800	850	900	950	1000	1050	1100	1150	1200	1250	1300	1350	1400	
L	315	365	415	465	515	565	615	665	715	765	815	865	915	965	1015	1065	1115	1165	1215	1265	1315	1365	1415	1465	1515	1565	1615	1665	
A	0	0	0	0	0	50	100	150	200	50	100	150	200	50	100	150	200	50	100	150	200	50	100	150	200	50	100	150	200
M	0	0	0	0	0	1	1	1	1	2	2	2	2	3	3	3	3	4	4	4	4	5	5	5	5	6	6	6	6
N	8	10	10	10	10	12	12	12	14	14	14	14	14	16	16	16	16	18	18	18	18	20	20	20	20	22	22	22	22
KG	9.5	10.3	11	11.8	12.5	13.4	14.2	14.9	15.7	16.5	17.4	18.3	19	19.7	20.5	21.3	22	22.9	23.6	24.3	25	25.8	26.5	27.2	27.9	28.6	29.5	30.3	

注：以上不含電機重量。Note: Not including motor weight.
如有特殊行程請先與技術人員聯繫。in case special stroke please contact technical services.

馬達右折-BR Motor Right Side

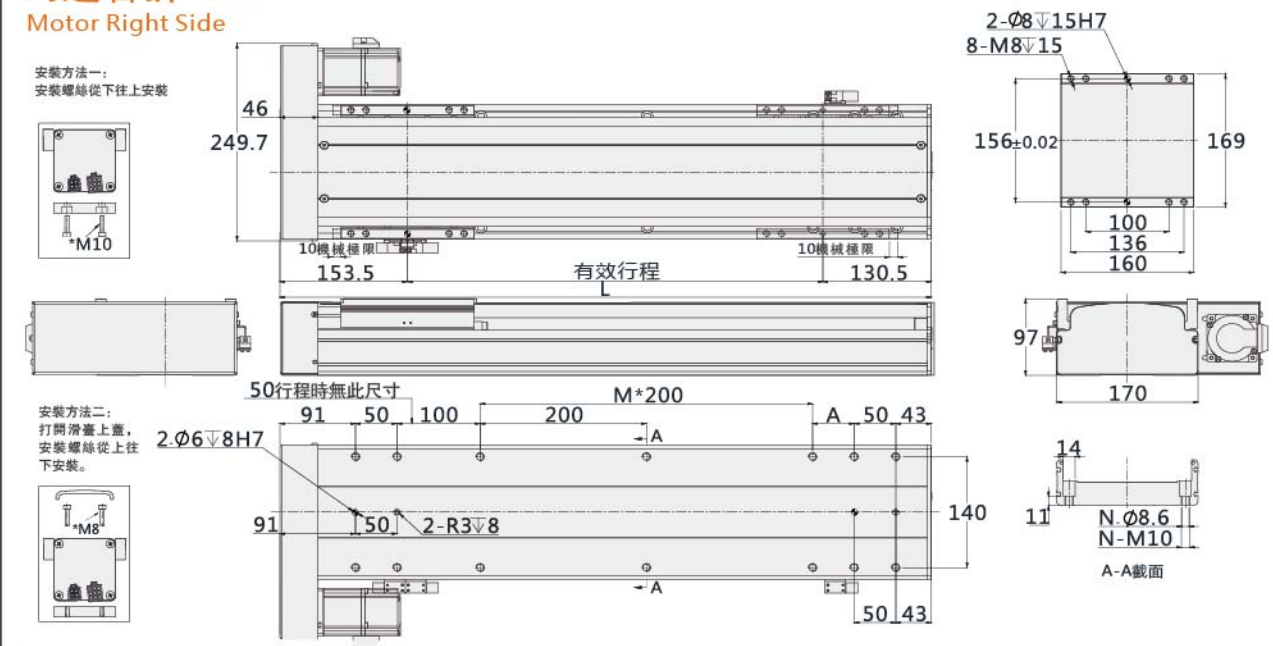

有效行程	50	100	150	200	250	300	350	400	450	500	550	600	650	700	750	800	850	900	950	1000	1050	1100	1150	1200	1250	1300	1350	1400	
L	334	384	434	484	534	584	634	684	734	784	834	884	934	984	1034	1084	1134	1184	1234	1284	1334	1384	1434	1484	1534	1584	1634	1684	
A	0	0	0	0	0	50	100	150	200	50	100	150	200	50	100	150	200	50	100	150	200	50	100	150	200	50	100	150	200
M	0	0	0	0	0	1	1	1	1	2	2	2	2	3	3	3	3	4	4	4	4	5	5	5	5	6	6	6	6
N	8	10	10	10	10	12	12	12	14	14	14	14	14	16	16	16	16	18	18	18	18	20	20	20	20	22	22	22	22
KG	10	10.7	11.5	12.2	13	13.8	14.9	15.4	16.2	17	17.8	18.6	19.4	20.1	20.9	21.7	22.5	23.3	24.1	24.9	25.7	26.5	27.3	28.1	28.9	29.6	30.5	31.2	

注：以上不含電機重量。Note: Not including motor weight.
如有特殊行程請先與技術人員聯繫。in case special stroke please contact technical services.

馬達下折-BD
Motor Bottom Side

安裝方法一：
安裝螺絲從下往上安裝

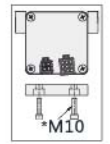

安裝方法二：
打開滑蓋上蓋，
安裝螺絲從上往
下安裝。

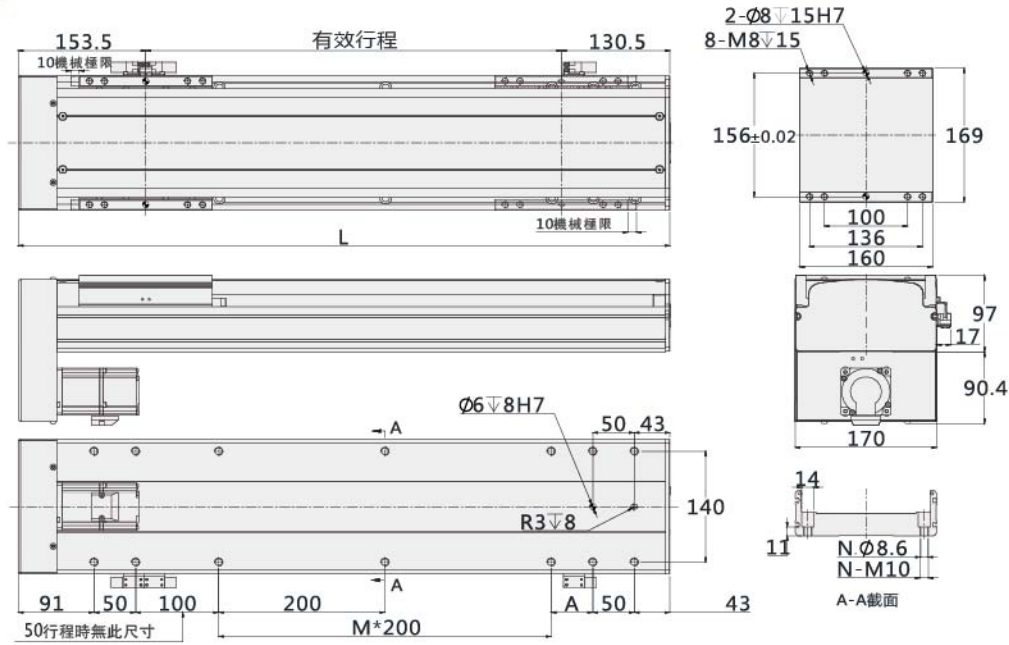
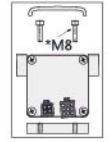

有效行程	50	100	150	200	250	300	350	400	450	500	550	600	650	700	750	800	850	900	950	1000	1050	1100	1150	1200	1250	1300	1350	1400
L	334	384	434	484	534	584	634	684	734	784	834	884	934	984	1034	1084	1134	1184	1234	1284	1334	1384	1434	1484	1534	1584	1634	1684
A	0	0	0	0	0	50	100	150	200	50	100	150	200	50	100	150	200	50	100	150	200	50	100	150	200	50	100	50
M	0	0	0	0	0	1	1	1	1	2	2	2	2	3	3	3	3	4	4	4	4	5	5	5	5	6	6	6
N	8	10	10	10	10	12	12	12	12	14	14	14	14	16	16	16	16	18	18	18	18	20	20	20	20	22	22	22
KG	10.2	10.9	11.7	12.9	13.2	14	15.1	15.6	16.4	17.2	18	18.8	19.8	20.3	21.2	21.9	22.7	23.5	24.3	25.1	25.9	26.7	27.5	28.3	29.2	29.8	30.7	31.4

注：以上不含電機重量。Note: Not including motor weight.
如有特殊行程請先與技術人員聯繫。in case special stroke please contact technical services.

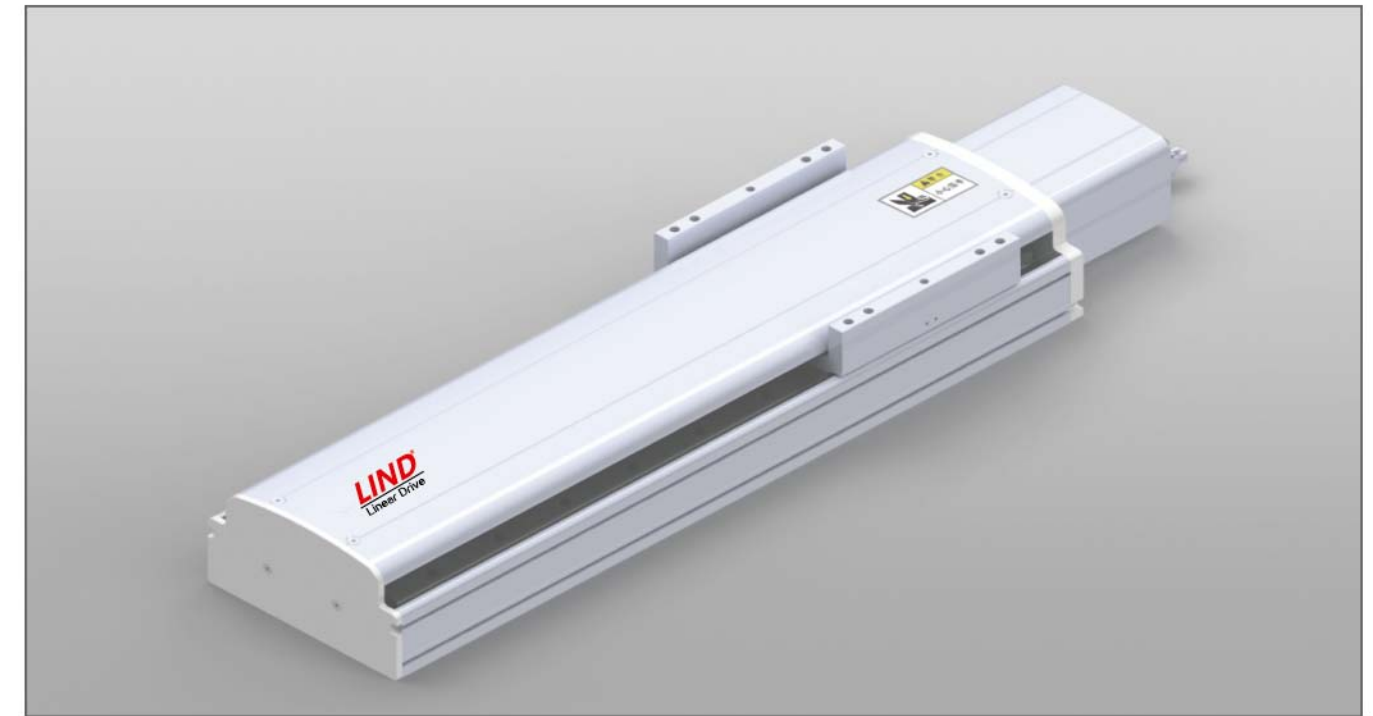

馬達安裝方式 Motor direction

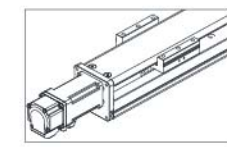

馬達直連外置-BC
Motor Exposed

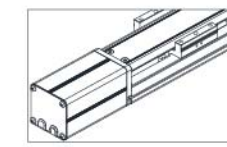

馬達直連內置-M
Motor built-in

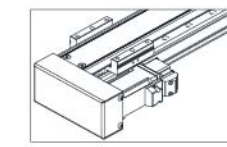

馬達左折-BL
Motor Left Side

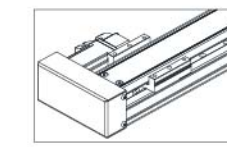

馬達右折-BR
Motor Right Side

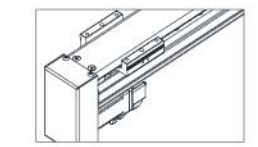

馬達下折-BD
Motor Bottom Side

型號表示方式 Guide for Model Selection

LEH22-L10-C-S100-BC-ZP75B-T3 _ - 001



*導程：電機旋轉一圈，滑臺移動的直線距離。

基本型號 Specification

馬達功率(W) Motor Output(W)	750				
馬達轉速(rpm/mim) Motor Speed(rpm/mim)	*3000				
滾珠絲杆導程-螺距(mm) Belt Lead(mm)	5	10	25	40	
最高速度(mm/s) Maximum Payload(mm/s)	250	500	1250	2000	
最大負載 Rated load(kg)	水平使用 Horizontal	150	150	105	43
	垂直使用 Vertical	58	50	22	13
額定推力 Rated thrust(n)	2553	1281	600	320	
行程範圍 Range of travel(mm)	50-2000MM/50行程遞增				
絲杆外徑 Screw diameter(mm)	* $\phi 25$		$\phi 20$		
重複位置精度 Repeatability(mm)	C7(C)	± 0.01			
	C5(P)	± 0.006			
導軌規格 Guide specification	W23XH18-2支				
聯軸器 coupling	16X19	12X19			
感應器 sensor	EE-SX674(NPN)				

*馬達加減速度時間為0.2S
motor speed is 0.2S.

*標配絲杆 $\phi 25$,也可定制 $\phi 32$ 。

*如有特殊行程請先與技術人員聯系。(可制定加長行程)
in case special stroke please contact technical services.

傳感器接綫圖 Sensor Wiring diagram

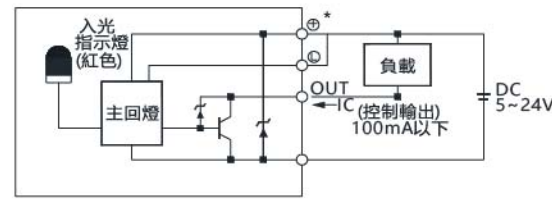

速度與行程 Speed and stroke

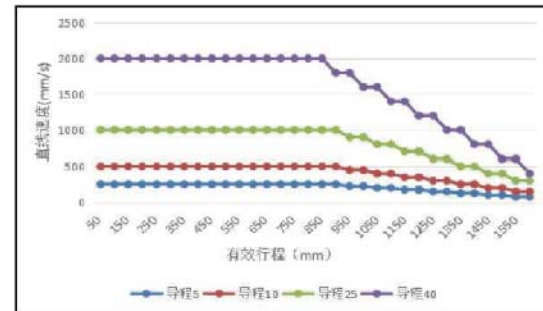

*行程超過900時, 絲杆旋轉會產生共振, 此時請將速度調低。
When the stroke is more than 750, the rotation of the screw will cause resonance, and then the speed will be lowered.

安裝示意圖 Installation Instrations&Dimentions

安裝方法一:
安裝螺絲從下往上安裝
method 1
fix the screw from bottom to up direction

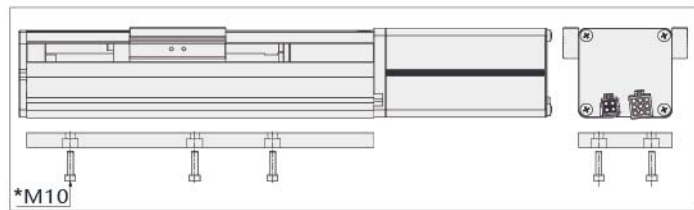

安裝方法二:
打開滑臺上蓋, 安裝螺絲從上往下安裝。
method 2:
open the cover, fix the screw from up to bottom

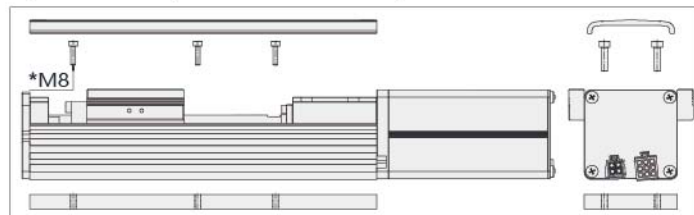

靜態力矩表 Static torque gauge

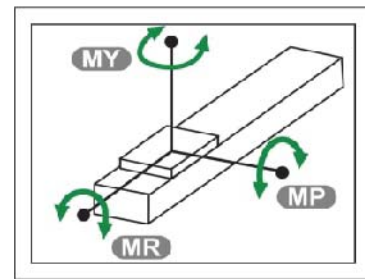

MY	2050 (N.M)
MP	2050 (N.M)
MR	1810 (N.M)

馬達直連外置-BC Motor Exposed

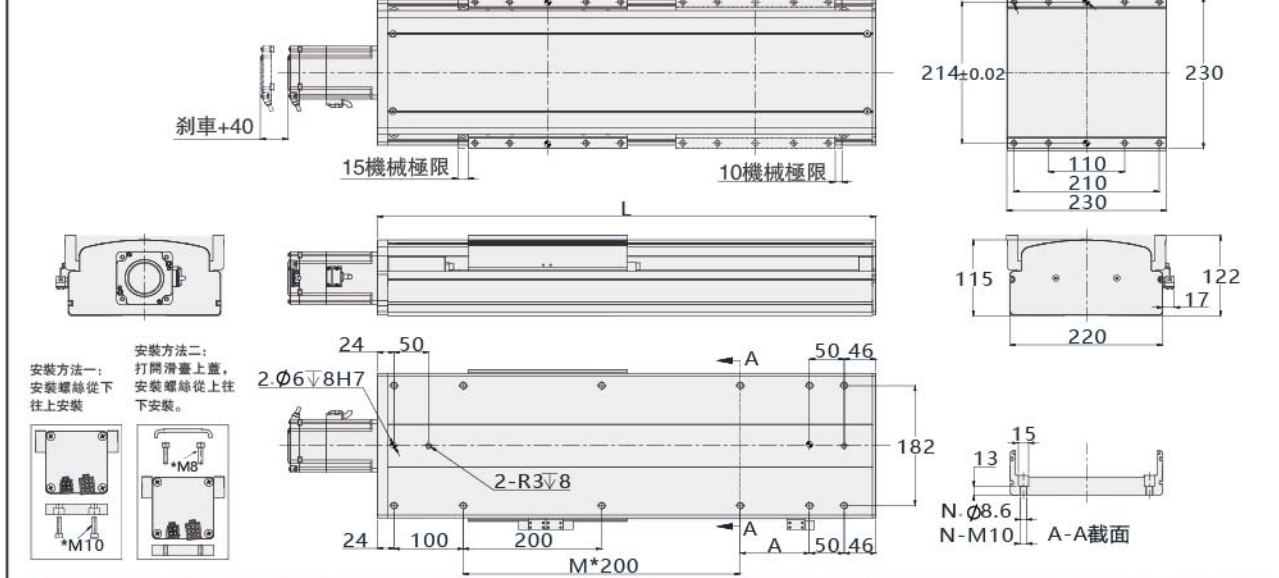

有效行程	50	100	150	200	250	300	350	400	450	500	550	600	650	700	750	800	850	900	950	1000	1050	1100	1150	1200	1250	1300	1350	1400	1450	1500	1550	1600
L	470	520	570	620	670	720	770	820	870	920	970	1020	1070	1120	1170	1220	1270	1320	1370	1420	1470	1520	1570	1620	1670	1720	1770	1820	1870	1920	1970	2020
A	50	100	150	200	50	100	150	200	50	100	150	200	50	100	150	200	50	100	150	200	50	100	150	200	50	100	150	200	50	100	150	200
M	1	1	1	1	2	2	2	2	3	3	3	3	4	4	4	4	5	5	5	5	6	6	6	6	7	7	7	7	8	8	8	8
N	10	10	10	10	12	12	12	12	14	14	14	14	16	16	16	16	18	18	18	18	20	20	20	20	22	22	22	22	24	24	24	24
KG	25.4	26.8	28.3	29.8	31.2	32.7	34.2	35.6	37.1	38.5	40.0	41.5	42.9	44.4	45.8	47.3	48.8	50.2	51.7	53.1	54.6	56.1	57.5	59.0	60.4	61.9	63.4	64.8	66.3	67.7	69.2	70.6

注: 以上不含電機重量。Note: Not including motor weight.
如有特殊行程請先與技術人員聯系。(可制定加長行程) in case special stroke please contact technical services.

馬達直連內置-M Motor built-in

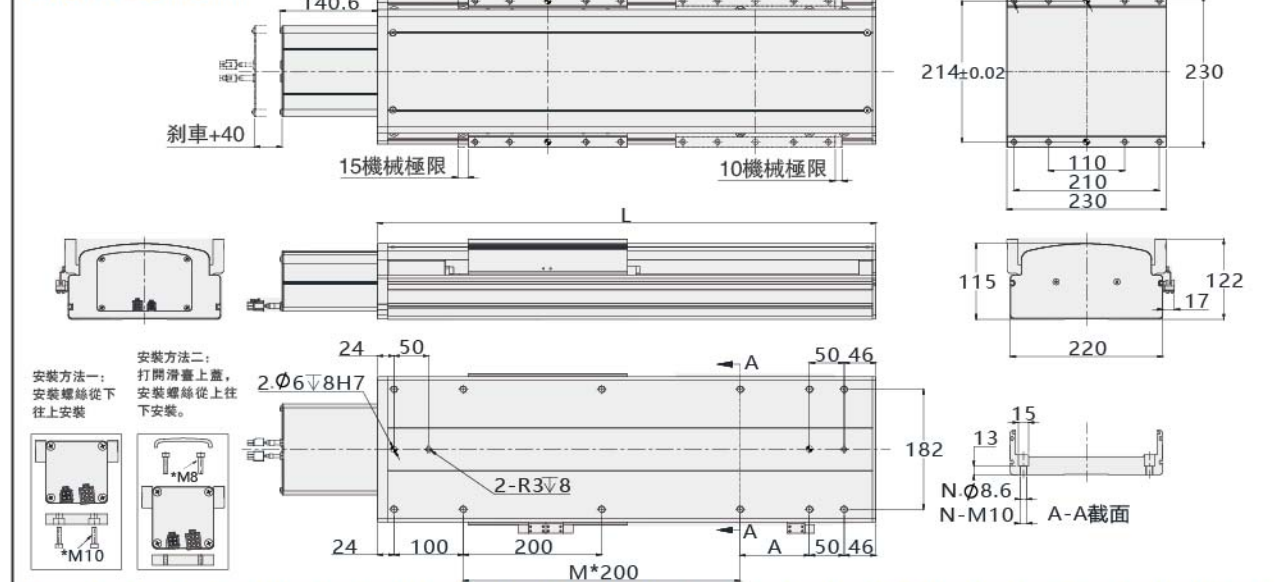

有效行程	50	100	150	200	250	300	350	400	450	500	550	600	650	700	750	800	850	900	950	1000	1050	1100	1150	1200	1250	1300	1350	1400	1450	1500	1550	1600
L	470	520	570	620	670	720	770	820	870	920	970	1020	1070	1120	1170	1220	1270	1320	1370	1420	1470	1520	1570	1620	1670	1720	1770	1820	1870	1920	1970	2020
A	50	100	150	200	50	100	150	200	50	100	150	200	50	100	150	200	50	100	150	200	50	100	150	200	50	100	150	200	50	100	150	200
M	1	1	1	1	2	2	2	2	3	3	3	3	4	4	4	4	5	5	5	5	6	6	6	6	7	7	7	7	8	8	8	8
N	10	10	10	10	12	12	12	12	14	14	14	14	16	16	16	16	18	18	18	18	20	20	20	20	22	22	22	22	24	24	24	24
KG	25.7	27.1	28.6	31.2	31.5	33.0	34.5	35.9	37.4	38.8	40.3	41.8	43.2	44.7	46.1	47.6	49.1	50.5	52.0	53.4	54.9	56.4	57.8	59.3	60.7	62.2	63.7	65.1	66.6	68.0	69.5	70.9

注: 以上不含電機重量。Note: Not including motor weight.
如有特殊行程請先與技術人員聯系。(可制定加長行程) in case special stroke please contact technical services.

馬達左折-BL Motor Left Side

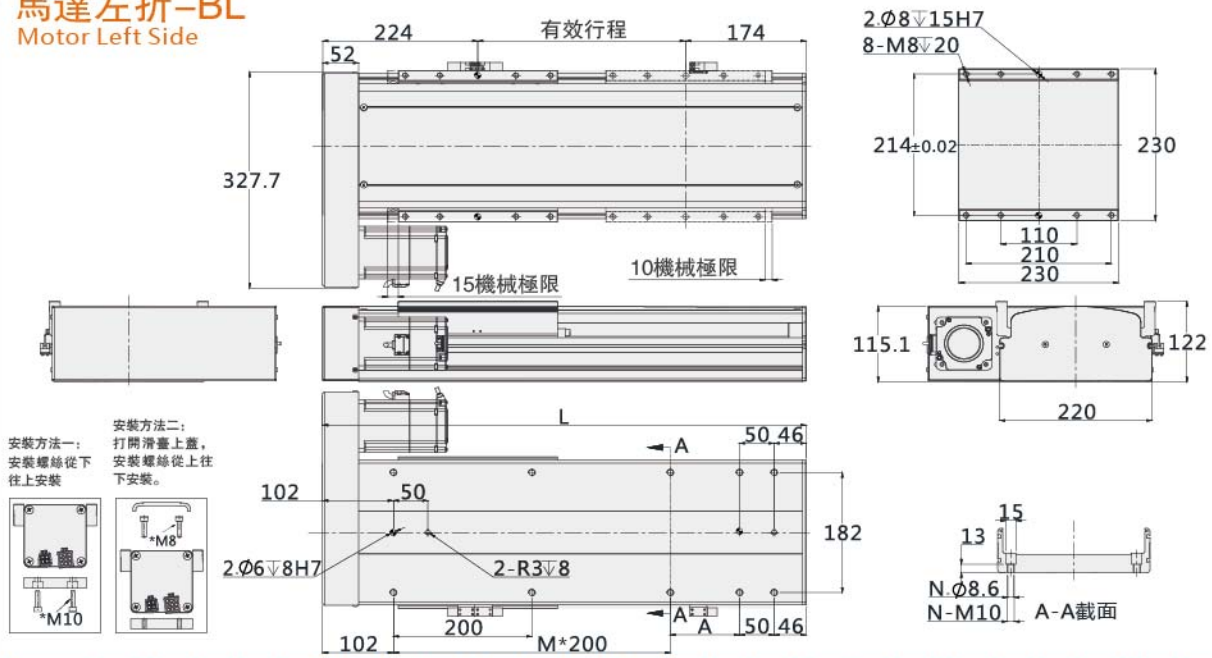

有效行程	50	100	150	200	250	300	350	400	450	500	550	600	650	700	750	800	850	900	950	1000	1050	1100	1150	1200	1250	1300	1350	1400	1450	1500	1550	1600
L	448	498	548	598	648	698	748	798	848	898	948	998	1048	1098	1148	1198	1248	1298	1348	1398	1448	1498	1548	1598	1648	1698	1748	1798	1848	1898	1948	1998
A	50	100	150	200	50	100	150	200	50	100	150	200	50	100	150	200	50	100	150	200	50	100	150	200	50	100	150	200	50	100	150	200
M	1	1	1	1	2	2	2	2	3	3	3	3	4	4	4	4	5	5	5	5	6	6	6	6	7	7	7	7	8	8	8	8
N	8	8	8	8	10	10	10	10	12	12	12	12	14	14	14	14	16	16	16	16	18	18	18	18	20	20	20	20	22	22	22	22
KG	24.4	25.8	27.3	28.8	30.2	31.7	33.2	34.6	36.1	37.5	39.0	40.5	41.9	43.4	44.8	46.3	47.8	49.2	50.7	52.1	53.6	55.1	56.5	58.0	59.4	60.9	62.4	63.8	65.3	66.7	68.2	69.6

注：以上不含電機重量。Note: Not including motor weight.
 如有特殊行程請先與技術人員聯繫。(可定制加長行程) in case special stroke please contact technical services.

馬達下折-BD Motor Bottom Side

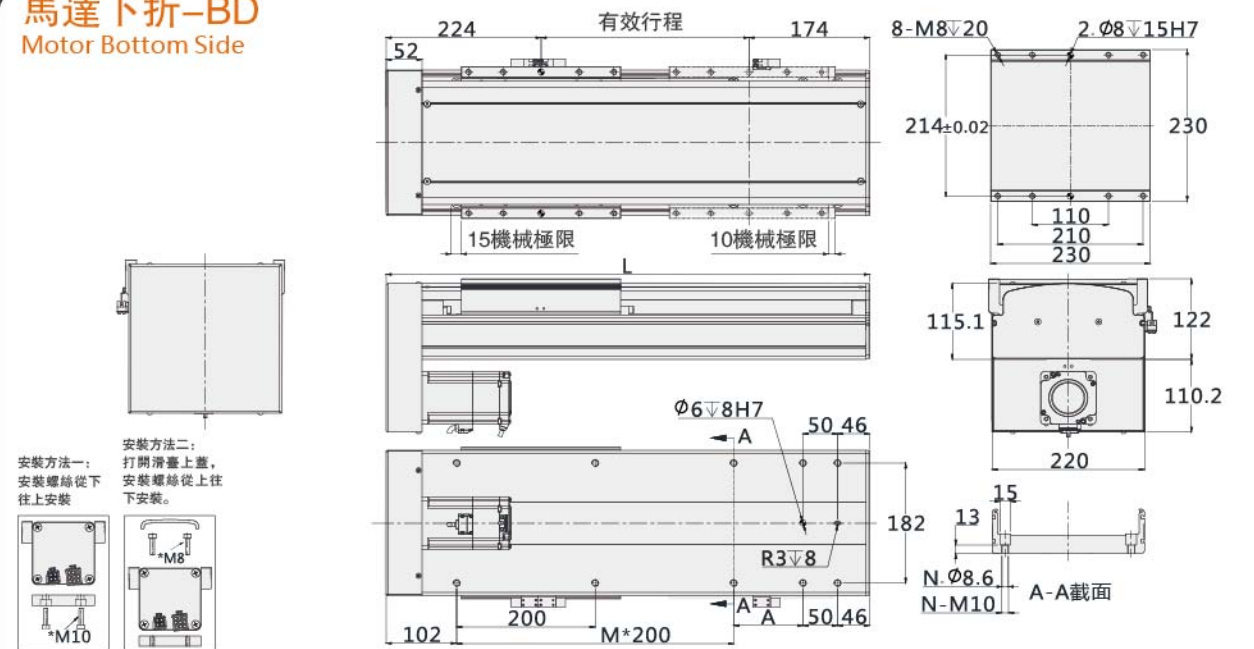

有效行程	50	100	150	200	250	300	350	400	450	500	550	600	650	700	750	800	850	900	950	1000	1050	1100	1150	1200	1250	1300	1350	1400	1450	1500	1550	1600
L	448	498	548	598	648	698	748	798	848	898	948	998	1048	1098	1148	1198	1248	1298	1348	1398	1448	1498	1548	1598	1648	1698	1748	1798	1848	1898	1948	1998
A	50	100	150	200	50	100	150	200	50	100	150	200	50	100	150	200	50	100	150	200	50	100	150	200	50	100	150	200	50	100	150	200
M	1	1	1	1	2	2	2	2	3	3	3	3	4	4	4	4	5	5	5	5	6	6	6	6	7	7	7	7	8	8	8	8
N	8	8	8	8	10	10	10	10	12	12	12	12	14	14	14	14	16	16	16	16	18	18	18	18	20	20	20	20	22	22	22	22
KG	24.4	25.8	27.3	28.8	30.2	31.7	33.2	34.6	36.1	37.5	39.0	40.5	41.9	43.4	44.8	46.3	47.8	49.2	50.7	52.1	53.6	55.1	56.5	58.0	59.4	60.9	62.4	63.8	65.3	66.7	68.2	69.6

注：以上不含電機重量。Note: Not including motor weight.
 如有特殊行程請先與技術人員聯繫。(可定制加長行程) in case special stroke please contact technical services.

馬達右折-BR Motor Right Side

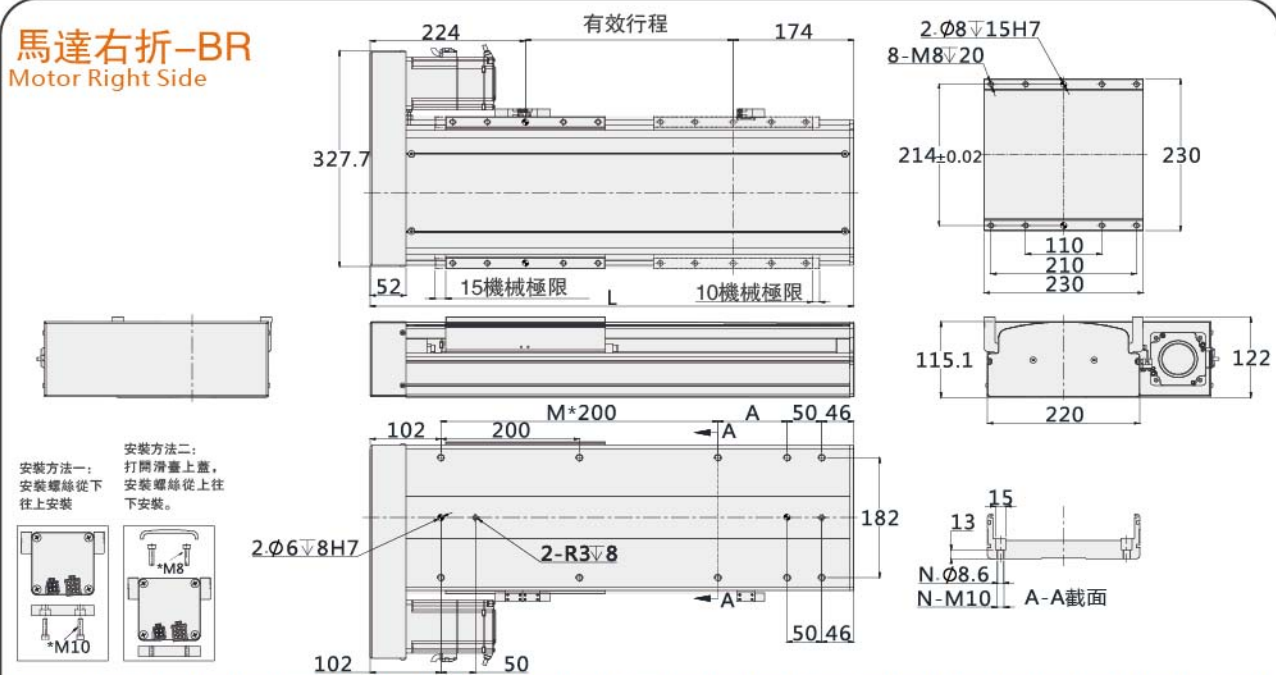

有效行程	50	100	150	200	250	300	350	400	450	500	550	600	650	700	750	800	850	900	950	1000	1050	1100	1150	1200	1250	1300	1350	1400	1450	1500	1550	1600
L	448	498	548	598	648	698	748	798	848	898	948	998	1048	1098	1148	1198	1248	1298	1348	1398	1448	1498	1548	1598	1648	1698	1748	1798	1848	1898	1948	1998
A	50	100	150	200	50	100	150	200	50	100	150	200	50	100	150	200	50	100	150	200	50	100	150	200	50	100	150	200	50	100	150	200
M	1	1	1	1	2	2	2	2	3	3	3	3	4	4	4	4	5	5	5	5	6	6	6	6	7	7	7	7	8	8	8	8
N	8	8	8	8	10	10	10	10	12	12	12	12	14	14	14	14	16	16	16	16	18	18	18	18	20	20	20	20	22	22	22	22
KG	24.4	25.8	27.3	28.8	30.2	31.7	33.2	34.6	36.1	37.5	39.0	40.5	41.9	43.4	44.8	46.3	47.8	49.2	50.7	52.1	53.6	55.1	56.5	58.0	59.4	60.9	62.4	63.8	65.3	66.7	68.2	69.6

注：以上不含電機重量。Note: Not including motor weight.
 如有特殊行程請先與技術人員聯繫。(可定制加長行程) in case special stroke please contact technical services.

密封式絲杆滑臺-LEC5

SEALED SCREW SLIDE

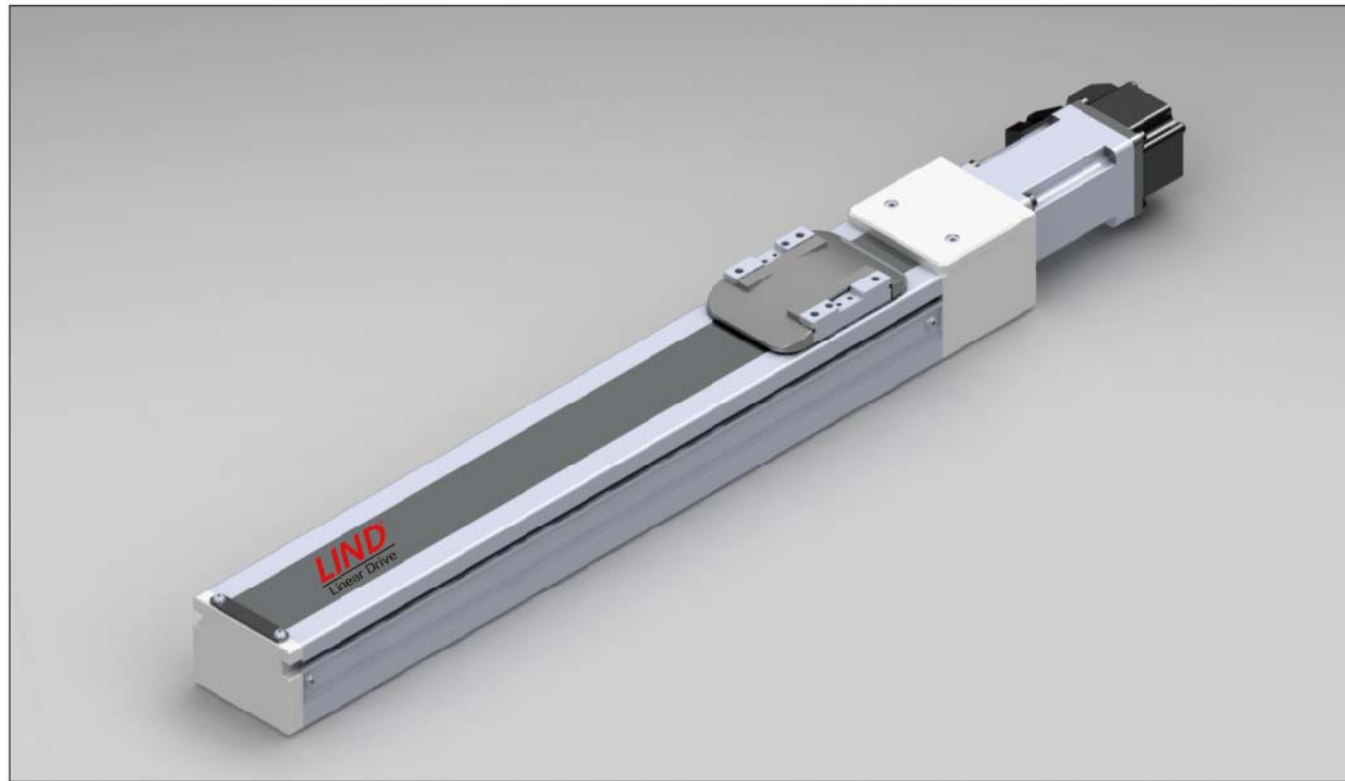

基本型號 Specification

馬達功率(W) Motor Output(W)	100W	
馬達轉速(rpm/mim) Motor Speed(rpm/mim)	*3000	
滾珠絲杆導程-螺距(mm) Belt Lead(mm)	5	10
最高速度(mm/s) Maximum Payload(mm/s)	250	500
最大負載 Rated load(kg)	水平使用 Horizontal	8
	垂直使用 Vertical	3
額定推力 Rated thrust(n)	341	170
行程範圍 Range of travel(mm)	50-600MM/50行程遞增	
絲杆外徑 Screw diameter(mm)	φ12	
重復位置精度 Repeatability(mm)	C7(C)	±0.01
	C5(P)	±0.006
導軌規格 Guide specification	8.5X24	
聯軸器 coupling	8X8	
感應器 sensor	EE-SX674(NPN)	

*馬達加減速度時間為0.2S
motor speed is 0.2S.

*如有特殊行程請先與技術人員聯系。

in case special stroke please contact technical services.

傳感器接線圖 Sensor Wiring diagram

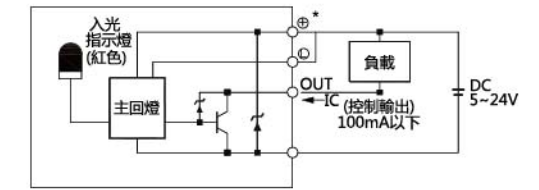

速度與行程 Speed and stroke

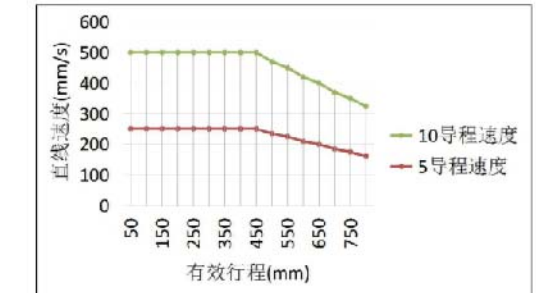

*行程超過450時，絲杆旋轉會產生共振，此時請將速度調低。

When the stroke is more than 500, the rotation of the screw will cause resonance, and then the speed will be lowered

馬達安裝方式 Motor direction

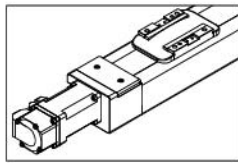

馬達直連外置-BC
Motor Exposed

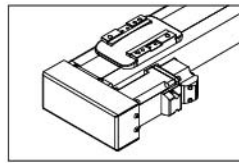

馬達左折-BL
Motor Left Side

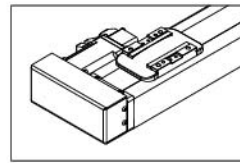

馬達右折-BR
Motor Right Side

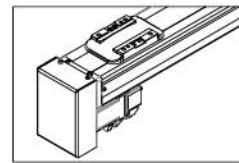

馬達下折-BD
Motor Bottom Side

型號表示方式 Guide for Model Selection

LEC5 - L10-C-S100-BC- ZP40B -T3 - - 001

本體型號 Base Style		絲杆導程(螺距) Ball Screw Lead	精度等級 Accuracy class	行程mm Stroke(mm)	馬達方式 Motor way	馬達品牌 Motor Type	馬達功率 Motor power	感應開關數量 Sensor quantity	感應器類型 Sensor type	備注 Non-standard,d.c.
L5	5mm	C	普通級C7 Common precision	50-600	BC	P 松下	10 100W	T3	3PCS	無 NPN
L10	10mm	P	研磨級C5 High precision		BL	M 三菱	20 -	T2	2PCS	
					BR	T 臺達	40 -	T1	1PCS	
					BD	Y 安川		E	無光電開關	
					Z	57步進電機		刹車 Brakes		
					无	其他品牌電機		無 無刹車		
								B 帶刹車		

*導程：電機旋轉一圈，滑臺移動的直線距離。

安裝示意圖 Installation Instrations&Dimentions

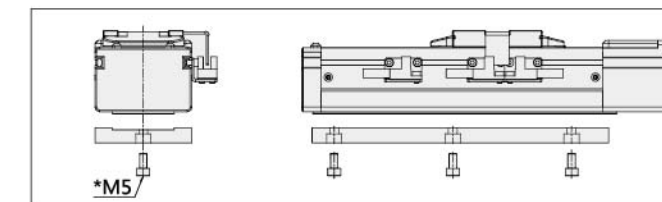

安裝方式：

安裝螺絲從下往上安裝

*注意鎖緊螺絲裝入滑臺的長度不得超過8mm，否則會與內部干涉。

Note that the length of the locking screw installed in the slide shall not exceed 9mm, otherwise it will interfere with the internal.

靜態力矩表 Static torque gauge

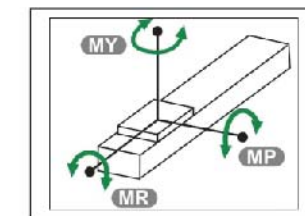

MY	16 (N.M)
MP	20 (N.M)
MR	19 (N.M)

馬達直連外置-BC Motor Exposed

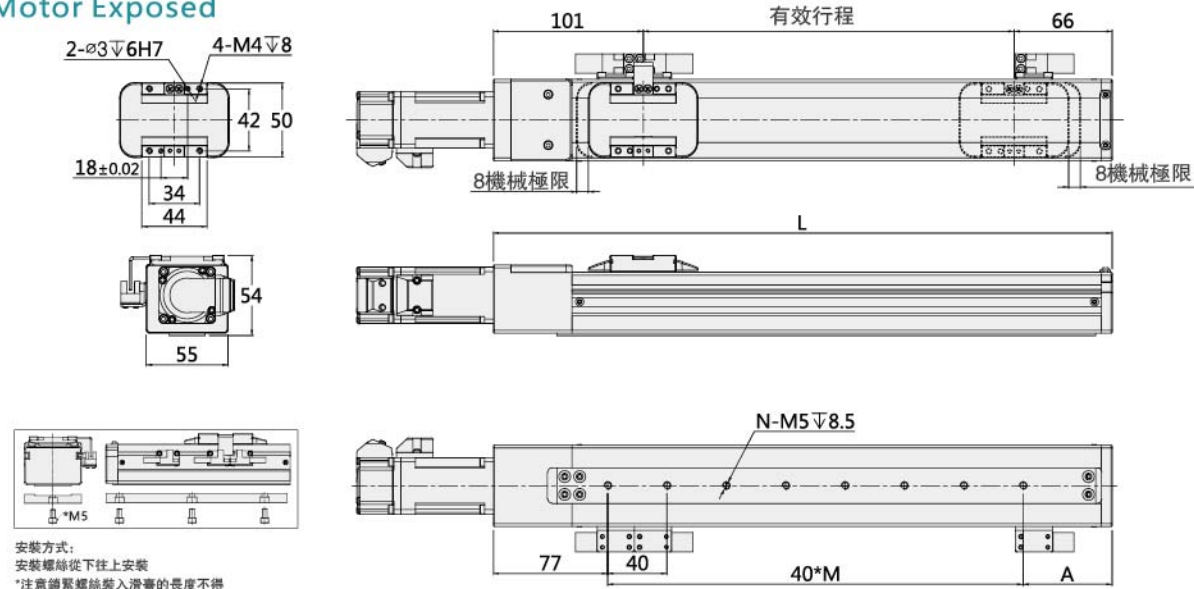

安裝方式:
安裝螺絲從下往上安裝
*注意請緊螺絲裝入滑蓋的長度不得超過8mm, 否則會與內部干涉。

有效行程	50	100	150	200	250	300	350	400	450	500	550	600
L	217	267	317	367	417	467	517	567	617	667	717	767
A	60	30	40	50	60	30	40	50	60	30	40	50
M	2	4	5	6	7	9	10	11	12	14	15	16
N	3	5	6	7	8	10	11	12	13	15	16	17
KG	2.1	2.2	2.3	2.4	2.5	2.6	2.7	2.8	2.9	3.0	3.1	3.2

注: 以上不含電機重量。Note: Not including motor weight.
如有特殊行程請先與技術人員聯繫。(可定制加長行程) in case special stroke please contact technical services.

馬達右折-BR Motor Left Side

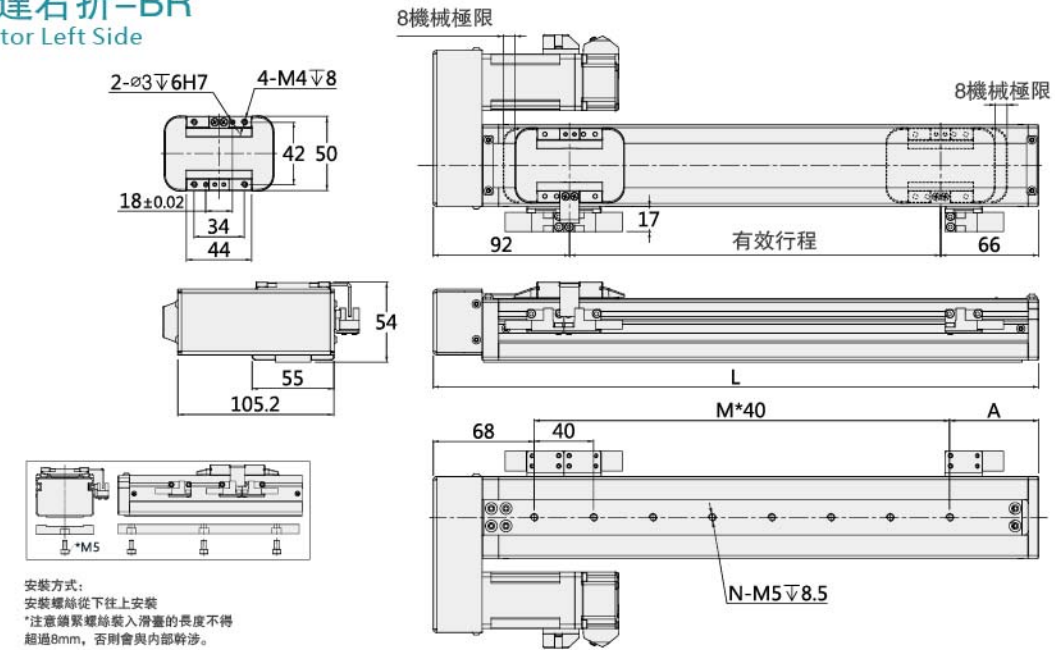

安裝方式:
安裝螺絲從下往上安裝
*注意請緊螺絲裝入滑蓋的長度不得超過8mm, 否則會與內部干涉。

有效行程	50	100	150	200	250	300	350	400	450	500	550	600
L	208	258	308	358	408	458	508	558	608	658	708	758
A	60	30	40	50	60	30	40	50	60	30	40	50
M	2	4	5	6	7	9	10	11	12	14	15	16
N	3	5	6	7	8	10	11	12	13	15	16	17
KG	2.2	2.3	2.4	2.5	2.6	2.7	2.8	2.9	3.0	3.1	3.2	3.3

注: 以上不含電機重量。Note: Not including motor weight.
如有特殊行程請先與技術人員聯繫。(可定制加長行程) in case special stroke please contact technical services.

馬達左折-BL Motor built-in

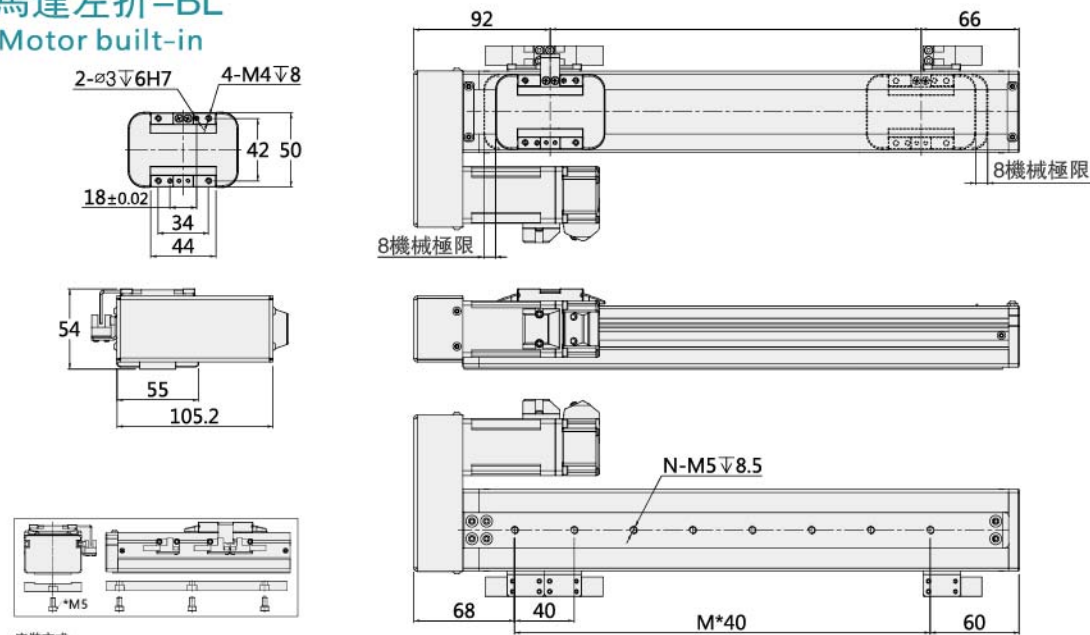

安裝方式:
安裝螺絲從下往上安裝
*注意請緊螺絲裝入滑蓋的長度不得超過8mm, 否則會與內部干涉。

有效行程	50	100	150	200	250	300	350	400	450	500	550	600
L	208	258	308	358	408	458	508	558	608	658	708	758
A	60	30	40	50	60	30	40	50	60	30	40	50
M	2	4	5	6	7	9	10	11	12	14	15	16
N	3	5	6	7	8	10	11	12	13	15	16	17
KG	2.2	2.3	2.4	2.5	2.6	2.7	2.8	2.9	3.0	3.1	3.2	3.3

注: 以上不含電機重量。Note: Not including motor weight.
如有特殊行程請先與技術人員聯繫。(可定制加長行程) in case special stroke please contact technical services.

馬達下折-BD Motor Right Side

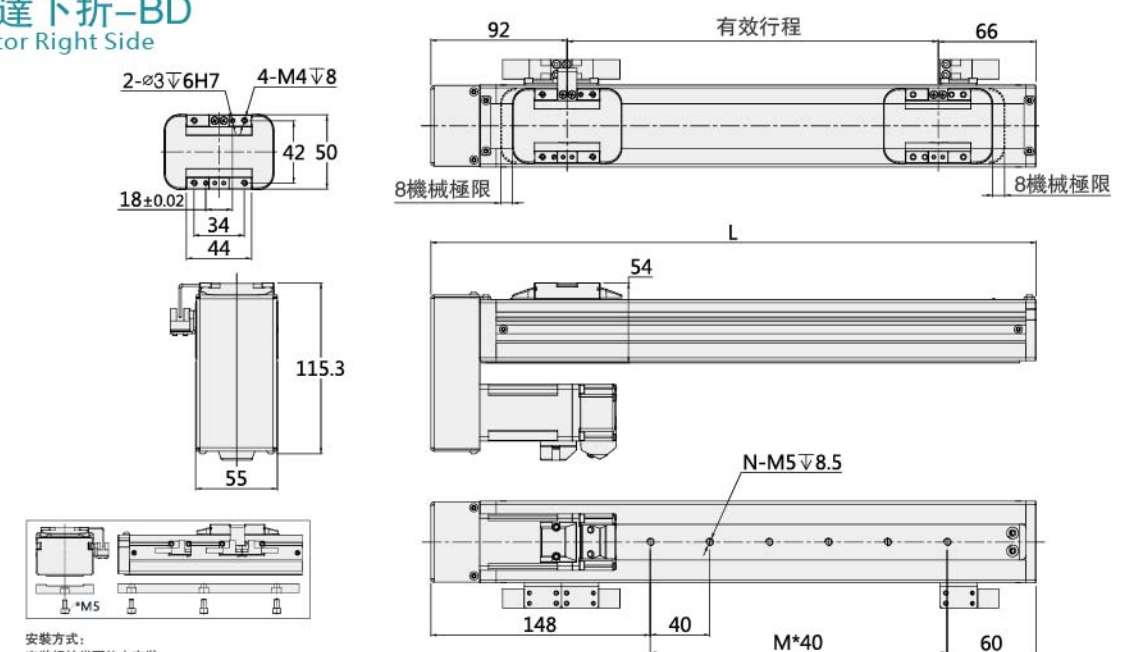

安裝方式:
安裝螺絲從下往上安裝
*注意請緊螺絲裝入滑蓋的長度不得超過8mm, 否則會與內部干涉。

有效行程	50	100	150	200	250	300	350	400	450	500	550	600
L	208	258	308	358	408	458	508	558	608	658	708	758
A	60	30	40	50	60	30	40	50	60	30	40	50
M	0	2	3	4	5	7	8	9	10	12	13	14
N	1	3	4	5	6	8	9	10	11	13	14	15
KG	2.2	2.3	2.4	2.5	2.6	2.7	2.8	2.9	3.0	3.1	3.2	3.3

注: 以上不含電機重量。Note: Not including motor weight.
如有特殊行程請先與技術人員聯繫。(可定制加長行程) in case special stroke please contact technical services.

密封式絲杆滑臺-LEC6

SEALED SCREW SLIDE

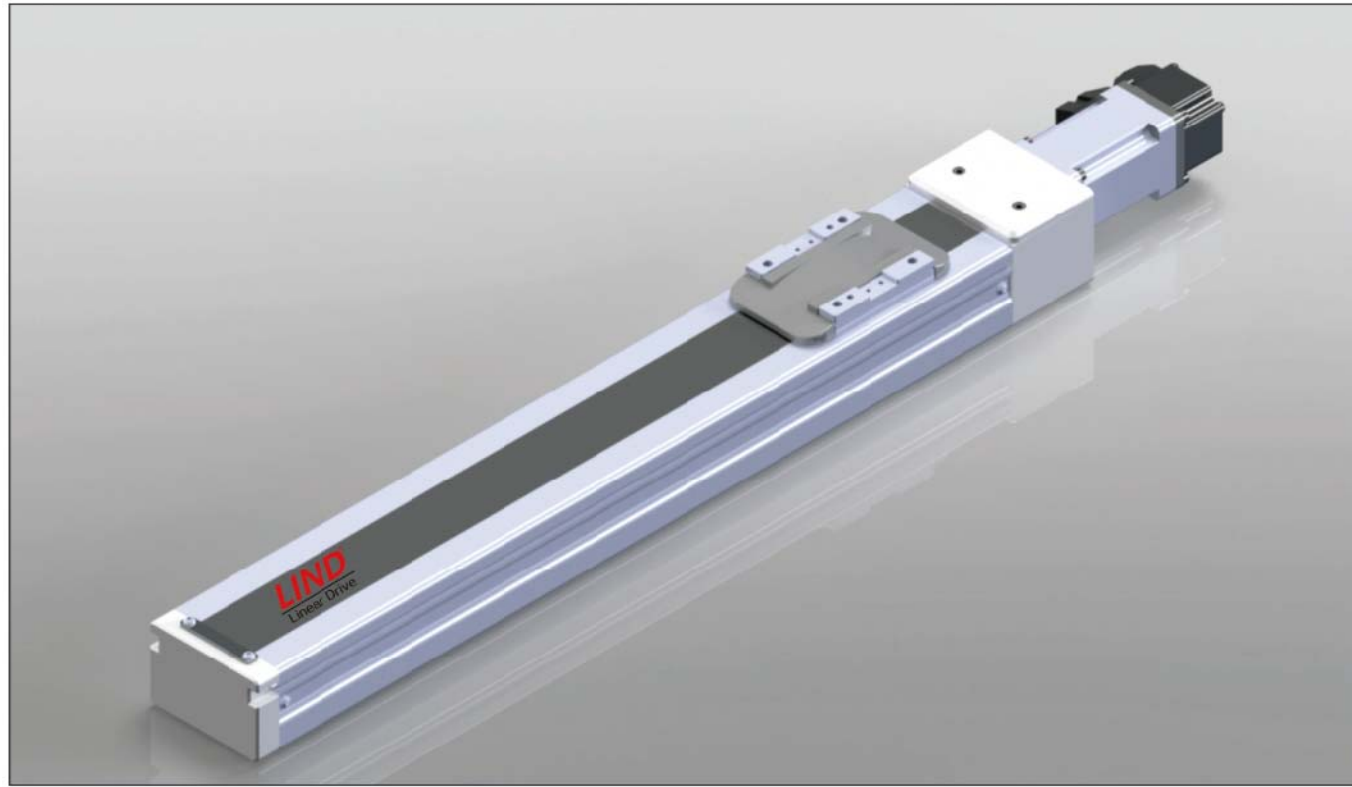

基本型號 Specification

馬達功率(W) Motor Output(W)	100W	
滾珠絲杆導程-螺距(mm) Belt Lead(mm)	5	10
最高速度(mm/s)	250	500
最大負載 Rated load(kg)	水平使用 Horizontal	18 10
	垂直使用 Vertical	9 5
額定推力 Rated thrust(n)	341	170
行程範圍 Range of travel(mm)	50-600MM/50行程遞增	
絲杆外徑 Screw diameter(mm)	φ12	
重複位置精度 Repeatability(mm)	C7(C)	±0.01
	C5(P)	±0.006
導軌規格 Guide specification	9.5X42	
聯軸器 coupling	8X8	
感應器 sensor	EE-SX674(NPN)	

*馬達加減速度時間為0.2S
motor speed is 0.2S.

*如有特殊行程請先與技術人員聯系。

in case special stroke please contact technical services.

傳感器接綫圖 Sensor Wiring diagram

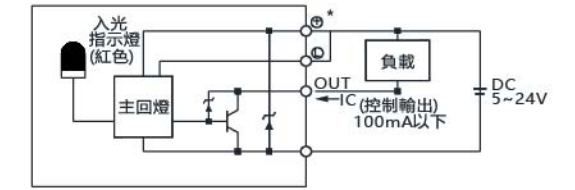

速度與行程 Speed and stroke

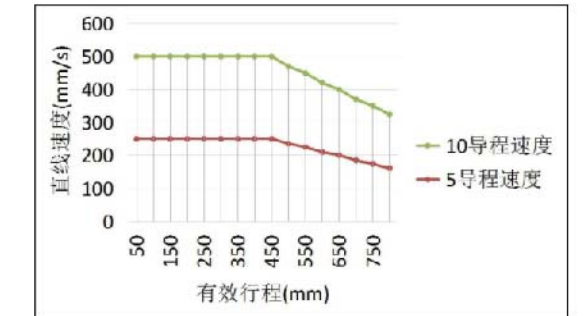

*行程超過500時，絲杆旋轉會產生共振，此時請將速度調低。

When the stroke is more than 500, the rotation of the screw will cause resonance, and then the speed will be lowered

馬達安裝方式 Motor direction

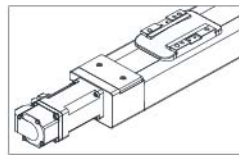

馬達直連外置-BC
Motor Exposed

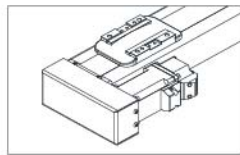

馬達左折-BL
Motor Left Side

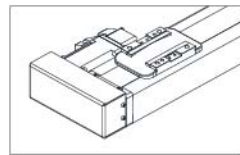

馬達右折-BR
Motor Right Side

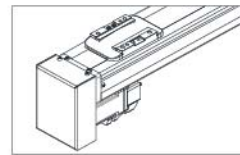

馬達下折-BD
Motor Bottom Side

型號表示方式 Guide for Model Selection

LEC6 - L10-C-S100-BC-ZP40B-T3 - 001

本體型號 Base Style	絲杆導程(螺距) Ball Screw Lead	精度等級 Accuracy class	行程mm Stroke(mm)	馬達方式 Motor way	馬達品牌 Motor Type	馬達功率 Motor power	感應開關數量 Sensor quantity	感應器類型 Sensor type	備注 Non-standard,d.c.
	L5 5mm	C 普通級C7 Common precision	50-600	BC 直連外置	P 松下	10 100W	T3 3PCS	無 NPN	
	L10 10mm	P 研磨級C5 High precision		BL 左折	M 三菱	20 -	T2 2PCS	P PNP	
				BR 右折	T 臺達	40 -	T1 1PCS		
				BD 下折	Y 安川		E 無光電開關		
				Z 客戶自配電機	57 57步進電機	剎車 Brakes			
				无 我司配電機	其他品牌電機	無 無剎車			
						B 帶剎車			

*導程：電機旋轉一圈，滑臺移動的直綫距離。

安裝示意圖 Installation Instrations&Dimentions

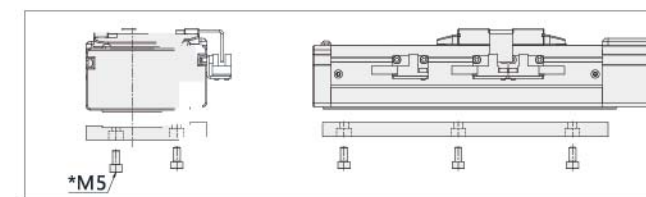

安裝方式：

安裝螺絲從下往上安裝

*注意鎖緊螺絲裝入滑臺的長度不得超過9mm，否則會與內部干涉。

Note that the length of the locking screw installed in the slide shall not exceed 9mm, otherwise it will interfere with the internal.

靜態力矩表 Static torque gauge

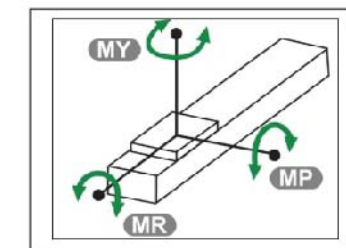

MY	70 (N.M)
MP	80 (N.M)
MR	75 (N.M)

馬達直接外置-BC Motor Exposed

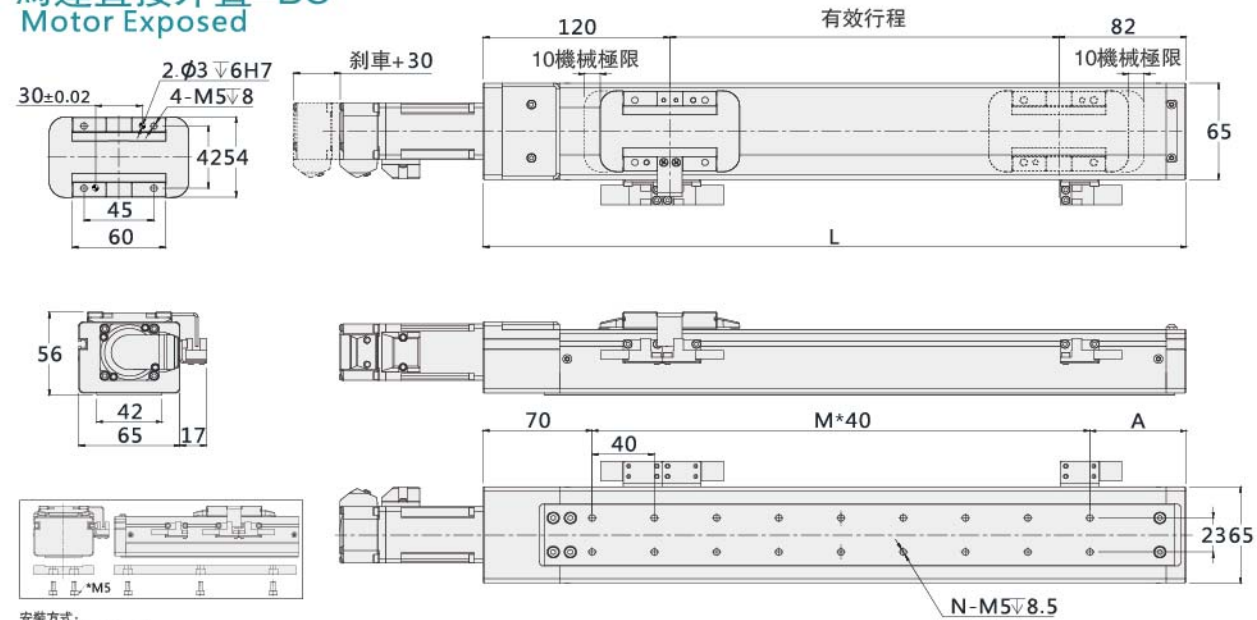

安裝方式:
安裝螺絲從下往上安裝
*注意鎖緊螺絲裝入滑蓋的長度不得超過9mm, 否則會與內部干涉。

有效行程	50	100	150	200	250	300	350	400	450	500	550	600	650
L	252	302	352	402	452	502	552	602	652	702	752	802	852
A	62	32	42	52	62	32	42	52	62	32	42	52	62
M	4	5	6	7	8	10	11	12	13	15	16	17	18
N	10	12	14	16	18	22	24	26	28	32	34	36	38
KG	2.5	2.6	2.8	2.9	3.1	3.2	3.4	3.5	3.7	3.9	4.1	4.3	4.5

注: 以上不含電機重量。Note: Not including motor weight.
如有特殊行程請先與技術人員聯系。in case special stroke please contact technical services.

馬達右折-BR Motor Left Side

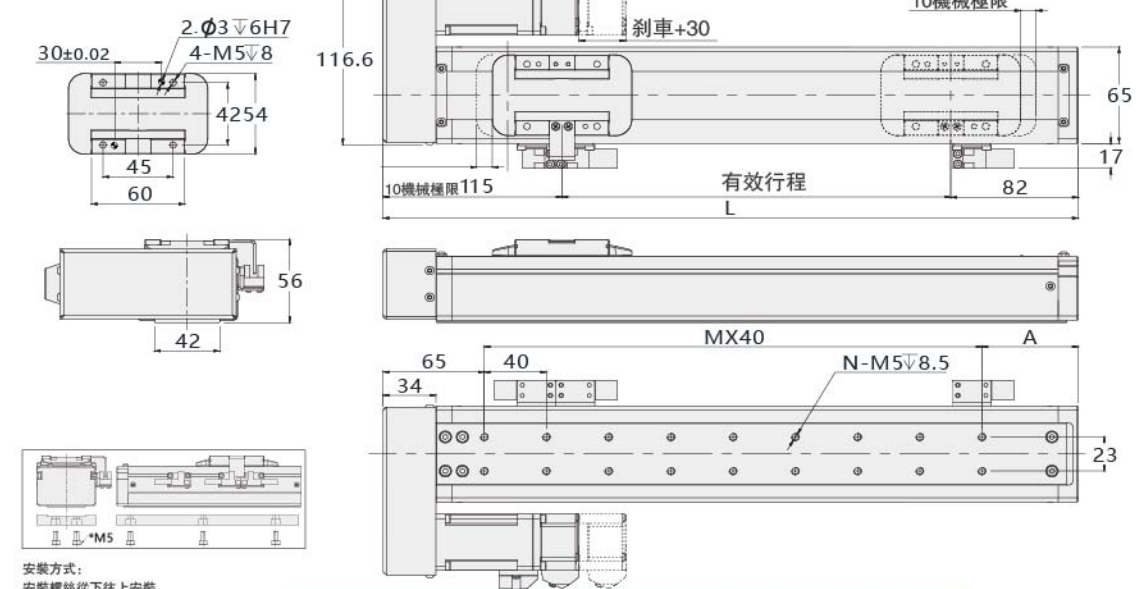

安裝方式:
安裝螺絲從下往上安裝
*注意鎖緊螺絲裝入滑蓋的長度不得超過9mm, 否則會與內部干涉。

有效行程	50	100	150	200	250	300	350	400	450	500	550	600	650
L	247	297	347	397	447	497	547	597	647	697	747	797	847
A	62	32	42	52	62	32	42	52	62	32	42	52	62
M	4	5	6	7	8	10	11	12	13	15	16	17	18
N	10	12	14	16	18	22	24	26	28	32	34	36	38
KG	2.6	2.7	2.9	3	3.2	3.3	3.5	3.6	3.8	4	4.2	4.4	4.6

注: 以上不含電機重量。Note: Not including motor weight.
如有特殊行程請先與技術人員聯系。in case special stroke please contact technical services.

馬達左折-BL Motor built-in

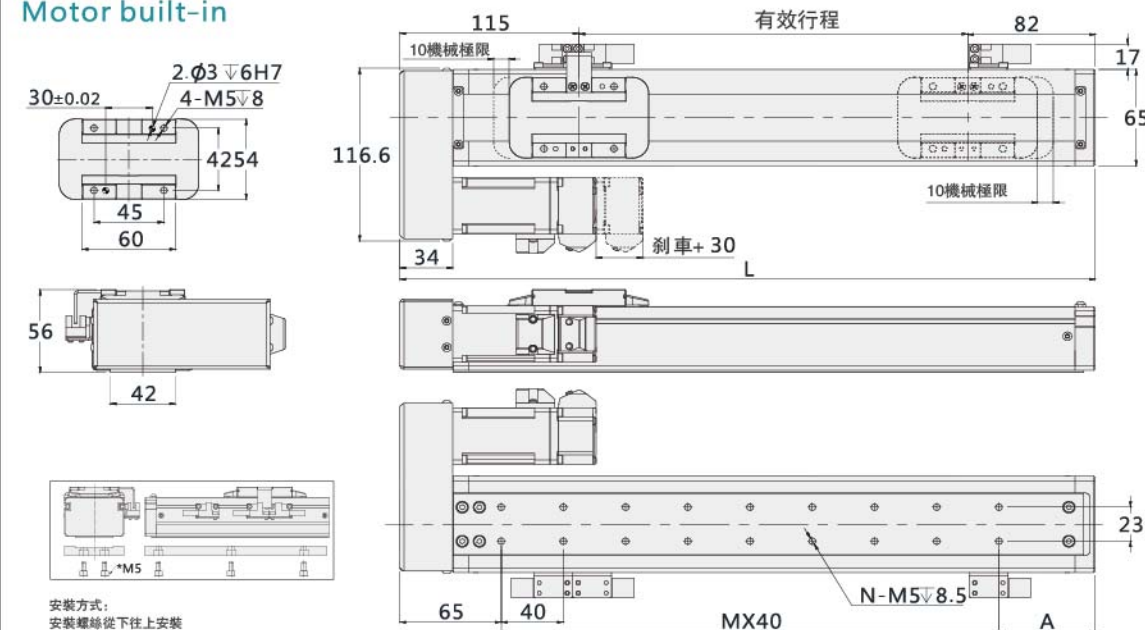

安裝方式:
安裝螺絲從下往上安裝
*注意鎖緊螺絲裝入滑蓋的長度不得超過9mm, 否則會與內部干涉。

有效行程	50	100	150	200	250	300	350	400	450	500	550	600	650
L	247	297	347	397	447	497	547	597	647	697	747	797	847
A	62	32	42	52	62	32	42	52	62	32	42	52	62
M	4	5	6	7	8	10	11	12	13	15	16	17	18
N	10	12	14	16	18	22	24	26	28	32	34	36	38
KG	2.6	2.7	2.9	3	3.2	3.3	3.5	3.6	3.8	4	4.2	4.4	4.6

注: 以上不含電機重量。Note: Not including motor weight.
如有特殊行程請先與技術人員聯系。in case special stroke please contact technical services.

馬達下折-BD Motor Right Side

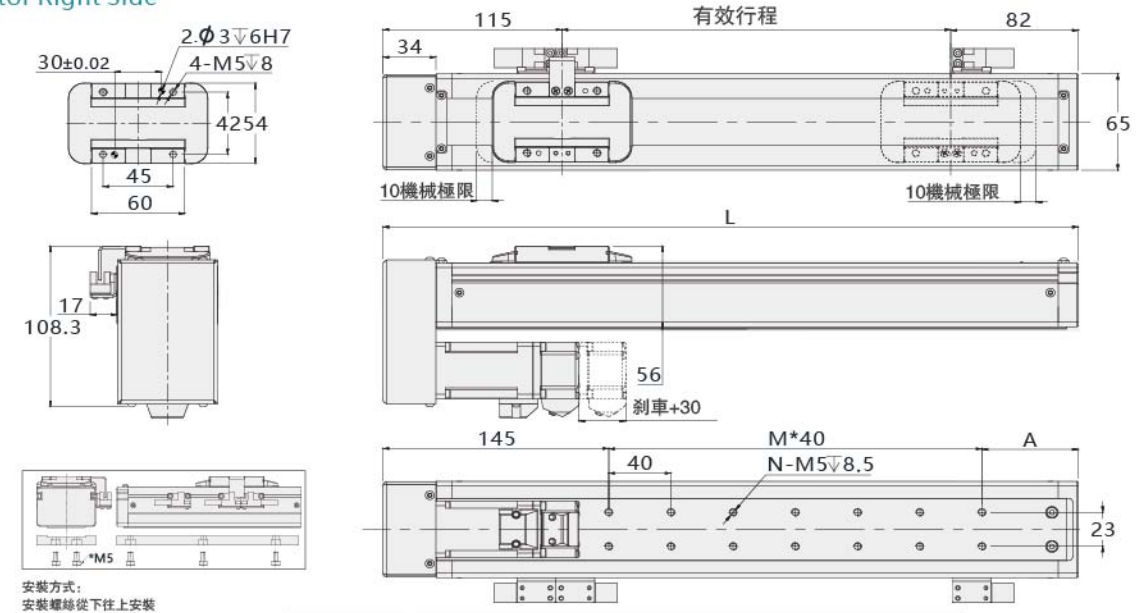

安裝方式:
安裝螺絲從下往上安裝
*注意鎖緊螺絲裝入滑蓋的長度不得超過9mm, 否則會與內部干涉。

有效行程	50	100	150	200	250	300	350	400	450	500	550	600	650
L	247	297	347	397	447	497	547	597	647	697	747	797	847
A	62	32	42	52	62	32	42	52	62	32	42	52	62
M	4	5	6	7	8	10	11	12	13	15	16	17	18
N	6	8	10	12	14	18	20	22	24	28	30	32	34
KG	2.6	2.7	2.9	3	3.2	3.3	3.5	3.6	3.8	4	4.2	4.4	4.6

注: 以上不含電機重量。Note: Not including motor weight.
如有特殊行程請先與技術人員聯系。in case special stroke please contact technical services.

密封式絲杆滑臺-LEC10

SEALED SCREW SLIDE

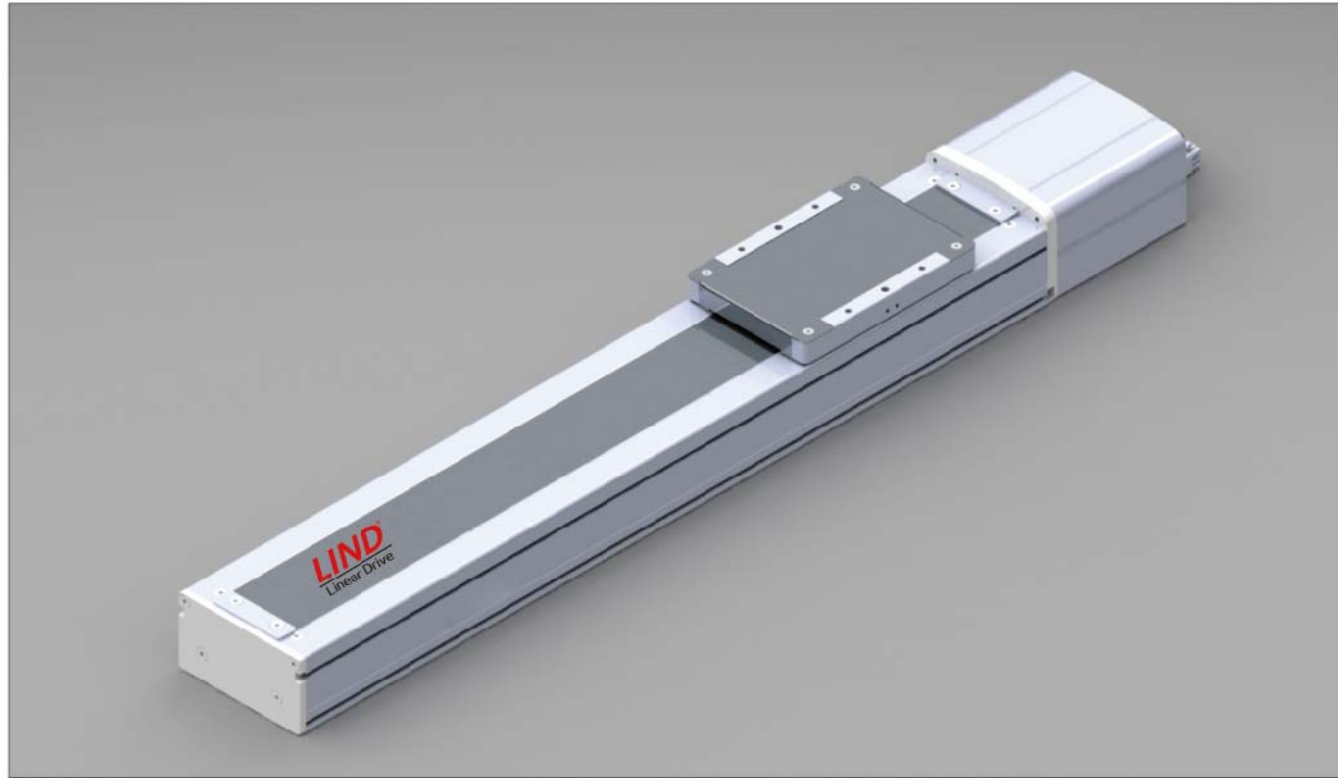

基本型號 Specification

馬達功率(W) Motor Output(W)	200W			
馬達轉速(rpm/mim) Motor Speed(rpm/mim)	*3000			
滾珠絲杆導程-螺距(mm) Belt Lead(mm)	5	10	20	32
最高速度(mm/s) Maximum Payload(mm/s)	250	500	1000	1600
最大負載 Rated load(kg)	水平使用Horizontal	50	40	20
	垂直使用 Vertical	15	12	6
額定推力 Rated thrust(n)	694	341	174	107
行程範圍 Range of travel(mm)	50-1100MM/50行程遞增			
絲杆外徑 Screw diameter(mm)	φ16			
重複位置精度 Repeatability(mm)	C7(C)	±0.01		
	C5(P)	±0.006		
導軌規格 Guide specification	W15XH12-2支			
聯軸器 coupling	10X14(11)*			
感應器 sensor	EE-SX674(NPN)			

*馬達加減速度時間為0.2S
motor speed is 0.2S.

*使用鬆下200W電機時聯軸器為10X11，其他品牌為10X14。

*如有特殊行程請先與技術人員聯系。

in case special stroke please contact technical services.

傳感器接綫圖 Sensor Wiring diagram

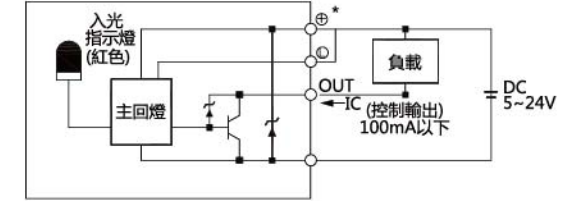

速度與行程 Speed and stroke

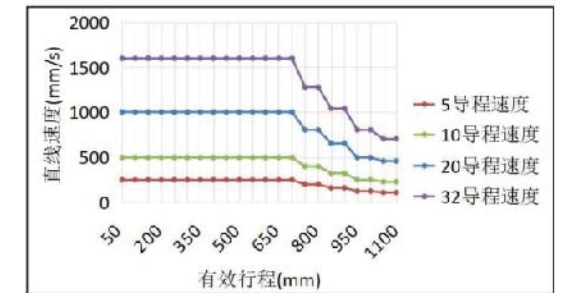

*行程超過750時，絲杆旋轉會產生共振，此時請將速度調低。

When the stroke is more than 500, the rotation of the screw will cause resonance, and then the speed will be lowered

馬達安裝方式 Motor direction

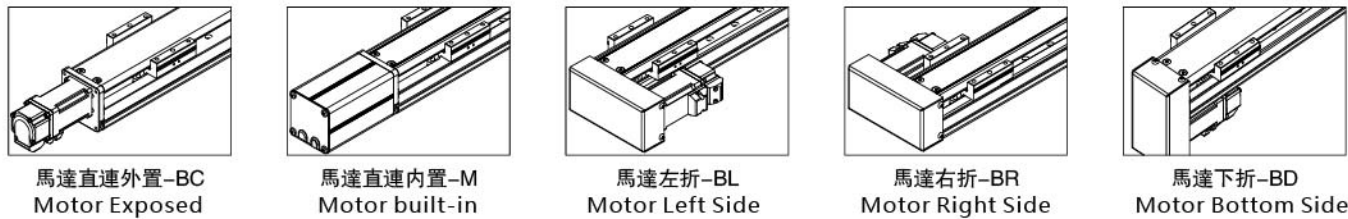

型號表示方式 Guide for Model Selection

LEC10-L10-C-S100-BC-ZP20B-T3--001

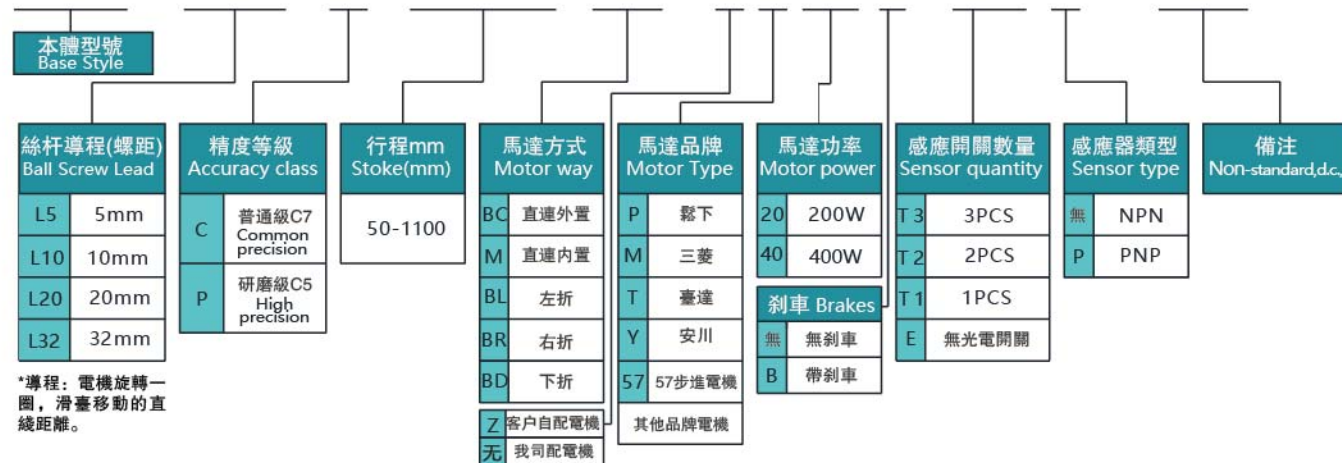

安裝示意圖 Installation Instrations&Dimention

安裝方式：
安裝螺絲從下往上安裝
*注意鎖緊螺絲裝入滑臺的長度不得超過11mm，否則會與內部干涉。

Note that the length of the locking screw installed in the slide shall not exceed 9mm, otherwise it will interfere with the internal.

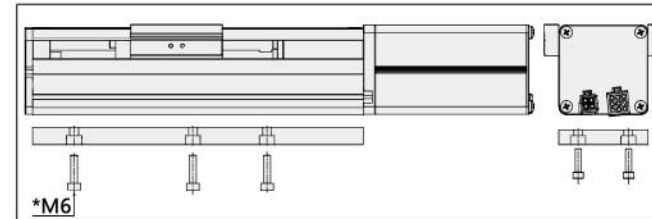

靜態力矩表 Static torque gauge

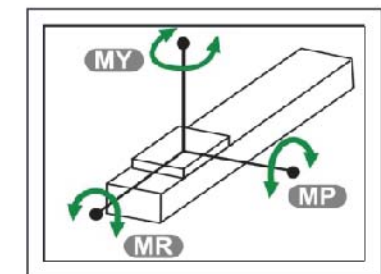

MY	160 (N.M)
MP	160 (N.M)
MR	140 (N.M)

馬達直接外置-BC Motor Exposed

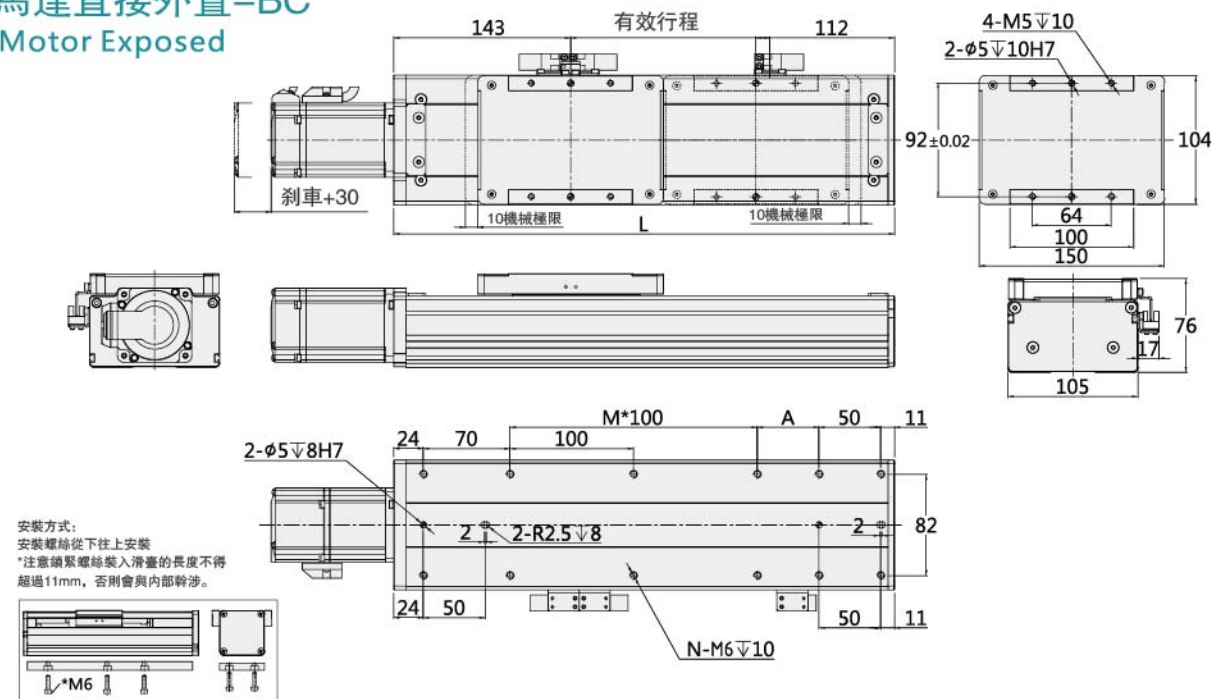

安裝方式:
安裝螺絲從下往上安裝
*注意鎖緊螺絲裝入滑蓋的長度不得超過11mm, 否則會與內部干涉。

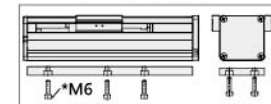

有效行程	50	100	150	200	250	300	350	400	450	500	550	600	650	700	750	800	850	900	950	1000	1050	1100
L	305	355	405	455	505	555	605	655	705	755	805	855	905	955	1005	1055	1105	1155	1205	1255	1305	1355
A	50	100	50	100	50	100	50	100	50	100	50	100	50	100	50	100	50	100	50	100	50	100
M	1	1	2	2	3	3	4	4	5	5	6	6	7	7	8	8	9	9	10	10	11	11
N	10	10	12	12	14	14	16	16	18	18	20	20	22	22	24	24	26	26	28	28	30	30
KG	5.7	6.1	6.6	7.0	7.4	7.8	8.3	8.7	9.1	9.6	10.0	10.4	10.9	11.3	11.7	12.1	12.6	13.0	13.4	13.9	14.3	14.7

注: 以上不含電機重量。Note: Not including motor weight.
如有特殊行程請先與技術人員聯系。in case special stroke please contact technical services.

馬達左折-BL Motor Left Side

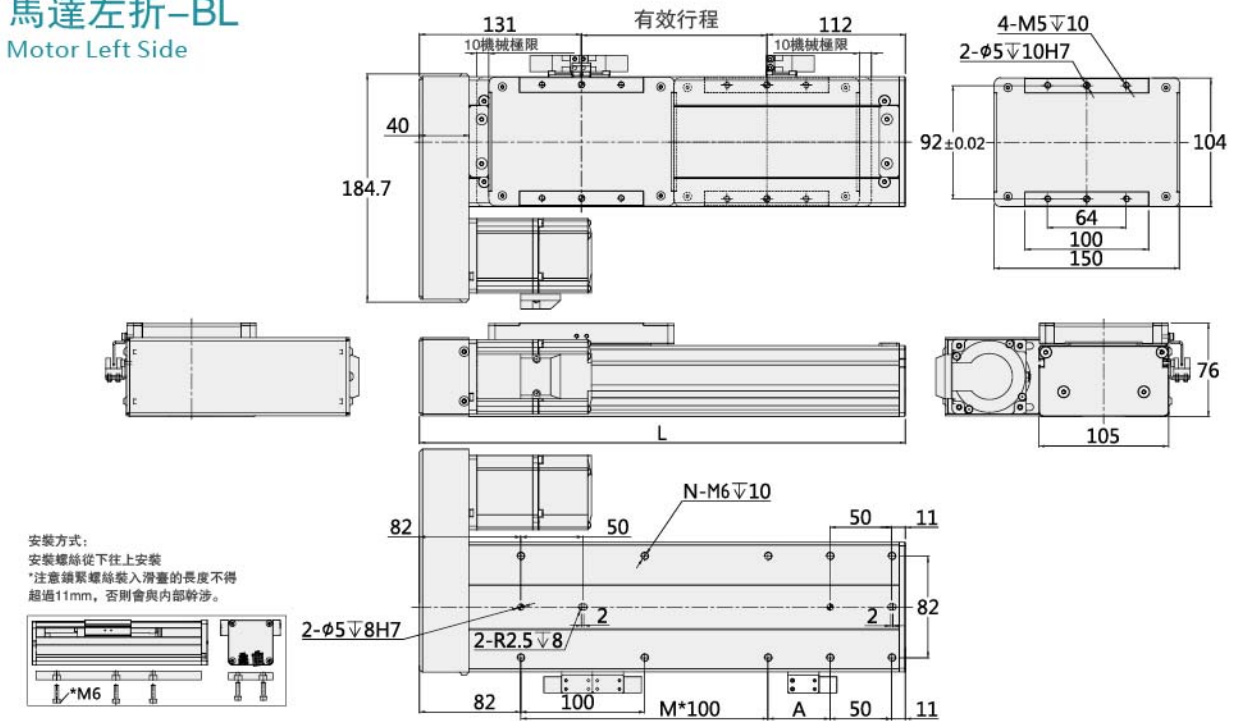

安裝方式:
安裝螺絲從下往上安裝
*注意鎖緊螺絲裝入滑蓋的長度不得超過11mm, 否則會與內部干涉。

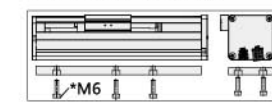

有效行程	50	100	150	200	250	300	350	400	450	500	550	600	650	700	750	800	850	900	950	1000	1050	1100
L	293	343	393	443	493	543	593	643	693	743	793	843	893	943	993	1043	1093	1143	1193	1243	1293	1343
A	50	100	50	100	50	100	50	100	50	100	50	100	50	100	50	100	50	100	50	100	50	100
M	1	1	2	2	3	3	4	4	5	5	6	6	7	7	8	8	9	9	10	10	11	11
N	8	8	10	10	12	12	14	14	16	16	18	18	20	20	22	22	24	24	26	26	28	28
KG	6.4	6.9	7.3	7.7	8.1	8.6	9.0	9.4	9.9	10.3	10.7	11.2	11.6	12.0	12.4	12.9	13.3	13.7	14.2	14.6	15.0	15.5

注: 以上不含電機重量。Note: Not including motor weight.
如有特殊行程請先與技術人員聯系。in case special stroke please contact technical services.

馬達直接內置-M Motor built-in

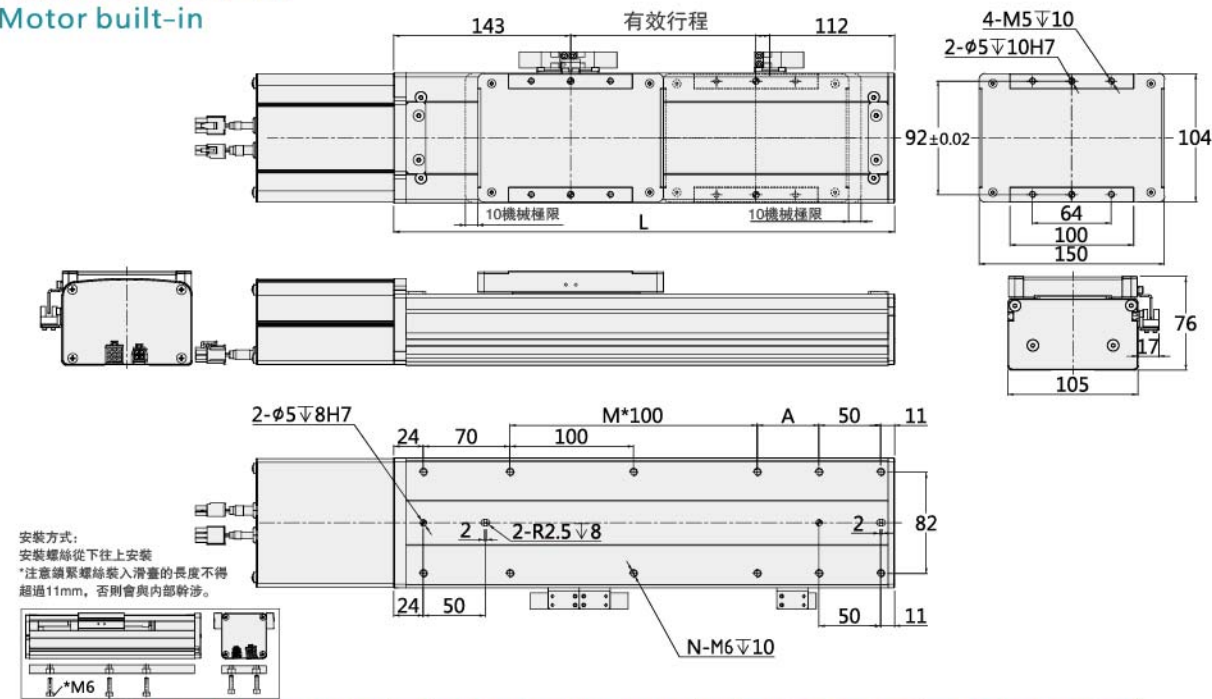

安裝方式:
安裝螺絲從下往上安裝
*注意鎖緊螺絲裝入滑蓋的長度不得超過11mm, 否則會與內部干涉。

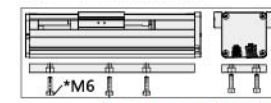

有效行程	50	100	150	200	250	300	350	400	450	500	550	600	650	700	750	800	850	900	950	1000	1050	1100
L	305	355	405	455	505	555	605	655	705	755	805	855	905	955	1005	1055	1105	1155	1205	1255	1305	1355
A	50	100	50	100	50	100	50	100	50	100	50	100	50	100	50	100	50	100	50	100	50	100
M	1	1	2	2	3	3	4	4	5	5	6	6	7	7	8	8	9	9	10	10	11	11
N	10	10	12	12	14	14	16	16	18	18	20	20	22	22	24	24	26	26	28	28	30	30
KG	5.7	6.1	6.6	7.0	7.4	7.8	8.3	8.7	9.1	9.6	10.0	10.4	10.9	11.3	11.7	12.1	12.6	13.0	13.4	13.9	14.3	14.7

注: 以上不含電機重量。Note: Not including motor weight.
如有特殊行程請先與技術人員聯系。in case special stroke please contact technical services.

馬達右折-BR Motor Right Side

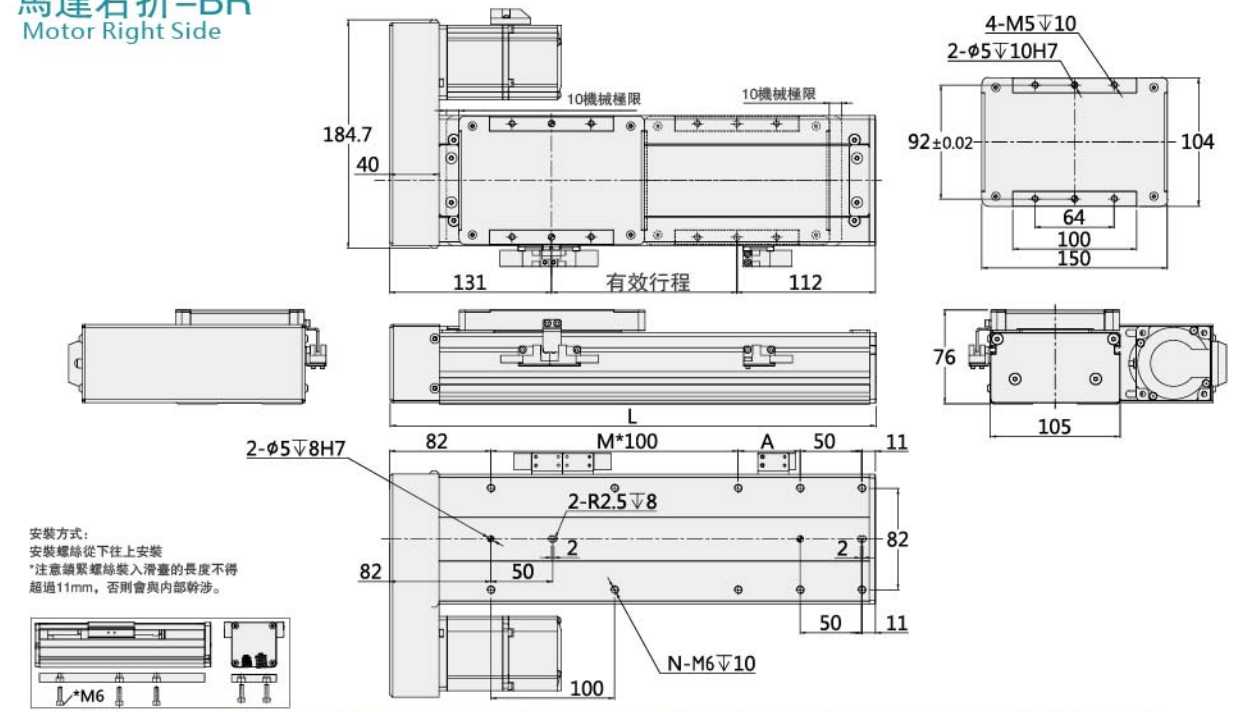

安裝方式:
安裝螺絲從下往上安裝
*注意鎖緊螺絲裝入滑蓋的長度不得超過11mm, 否則會與內部干涉。



有效行程	50	100	150	200	250	300	350	400	450	500	550	600	650	700	750	800	850	900	950	1000	1050	1100
L	293	343	393	443	493	543	593	643	693	743	793	843	893	943	993	1043	1093	1143	1193	1243	1293	1343
A	50	100	50	100	50	100	50	100	50	100	50	100	50	100	50	100	50	100	50	100	50	100
M	1	1	2	2	3	3	4	4	5	5	6	6	7	7	8	8	9	9	10	10	11	11
N	8	8	10	10	12	12	14	14	16	16	18	18	20	20	22	22	24	24	26	26	28	28
KG	6.4	6.9	7.3	7.7	8.1	8.6	9.0	9.4	9.9	10.3	10.7	11.2	11.6	12.0	12.4	12.9	13.3	13.7	14.2	14.6	15.0	15.5

注: 以上不含電機重量。Note: Not including motor weight.
如有特殊行程請先與技術人員聯系。in case special stroke please contact technical services.

馬達下折-BD
Motor Bottom Side

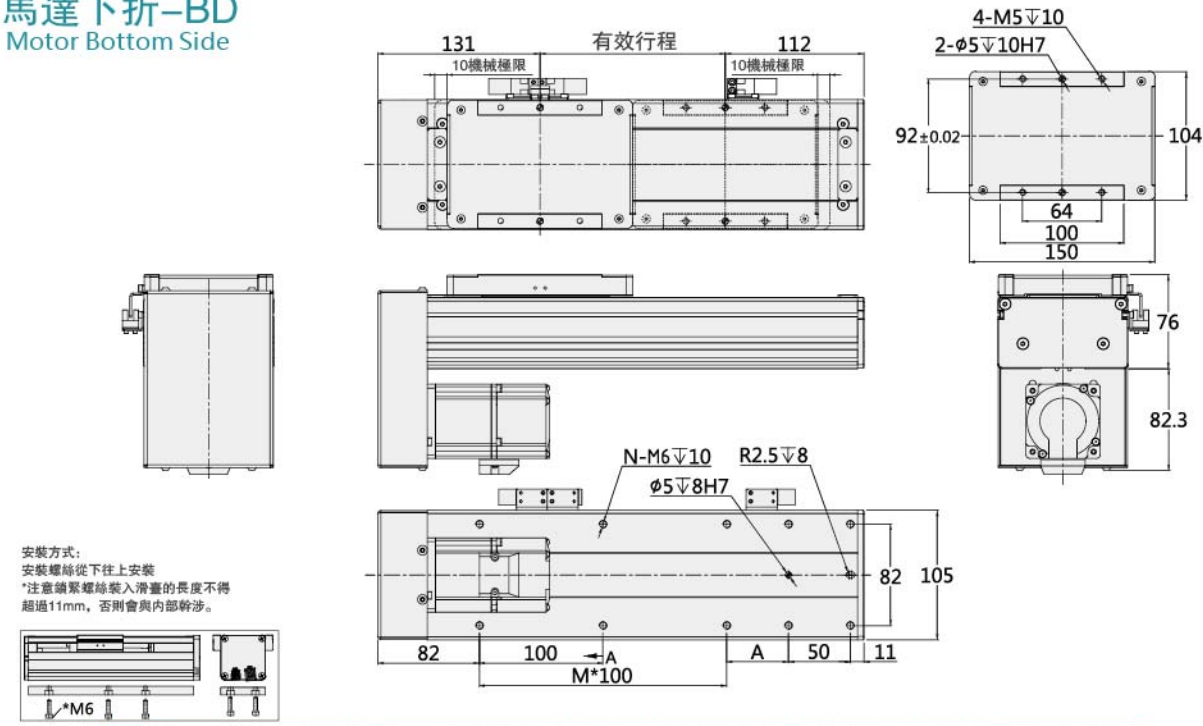

安裝方式:
安裝螺絲從下往上安裝
*注意鎖緊螺絲裝入滑臺的長度不得超過11mm, 否則會與內部干涉。

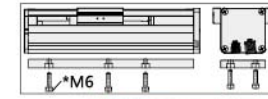

有效行程	50	100	150	200	250	300	350	400	450	500	550	600	650	700	750	800	850	900	950	1000	1050	1100
L	293	343	393	443	493	543	593	643	693	743	793	843	893	943	993	1043	1093	1143	1193	1243	1293	1343
A	50	100	50	100	50	100	50	100	50	100	50	100	50	100	50	100	50	100	50	100	50	100
M	1	1	2	2	3	3	4	4	5	5	6	6	7	7	8	8	9	9	10	10	11	11
N	8	8	10	10	12	12	14	14	16	16	18	18	20	20	22	22	24	24	26	26	28	28
KG	6.4	6.9	7.3	7.7	8.1	8.6	9.0	9.4	9.9	10.3	10.7	11.2	11.6	12.0	12.4	12.9	13.3	13.7	14.2	14.6	15.0	15.5

注: 以上不含電機重量。Note: Not including motor weight.
如有特殊行程請先與技術人員聯系。in case special stroke please contact technical services.

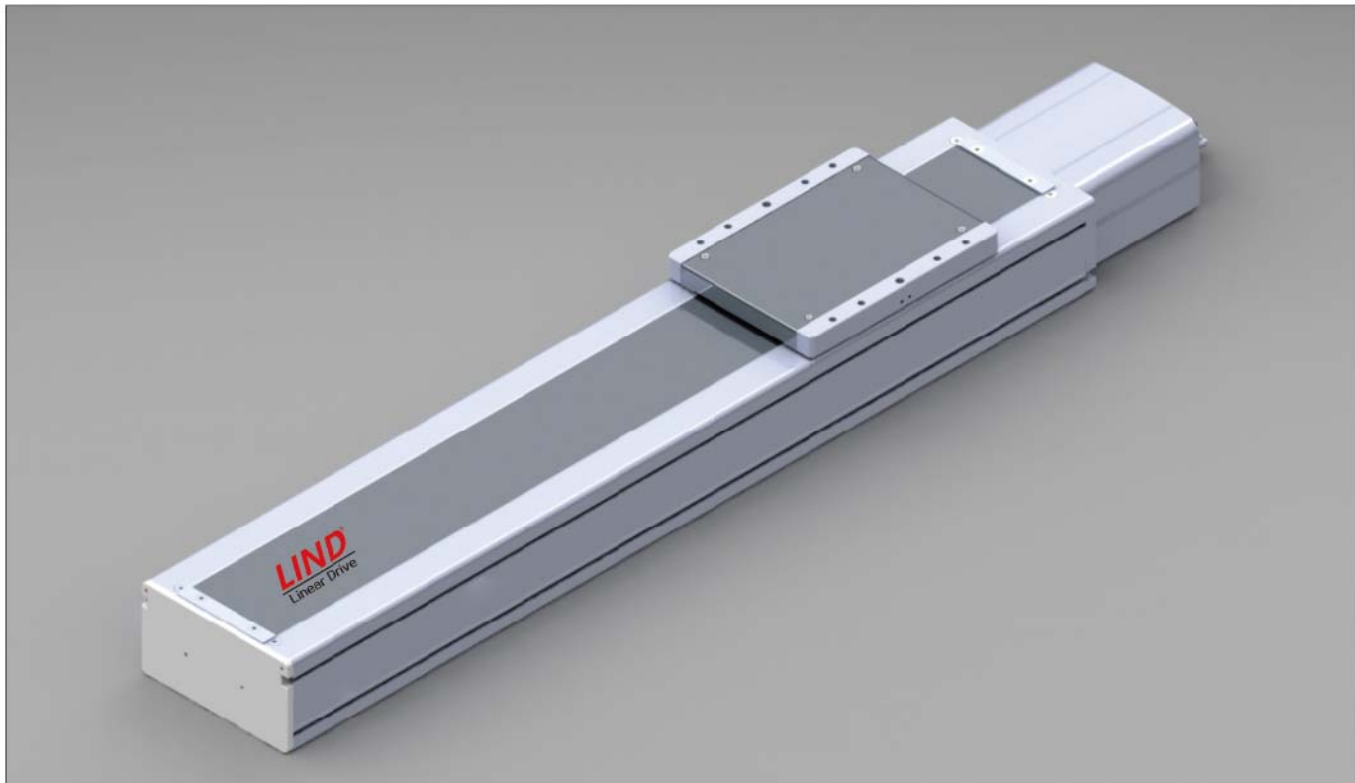

馬達安裝方式 Motor direction

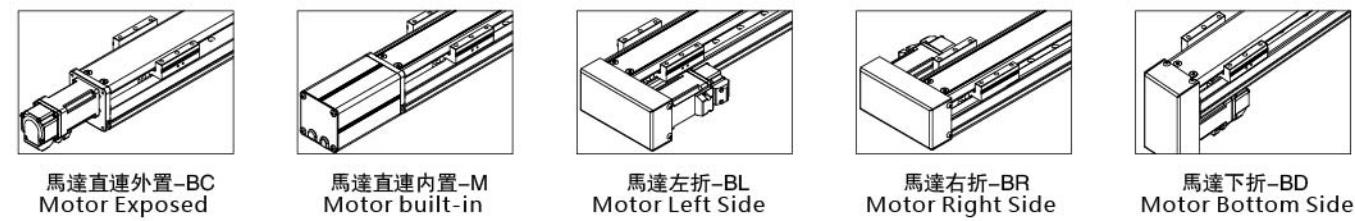

型號表示方式 Guide for Model Selection

LEC13-L10-C-S100-BC-ZP20B-T3 _ - 001

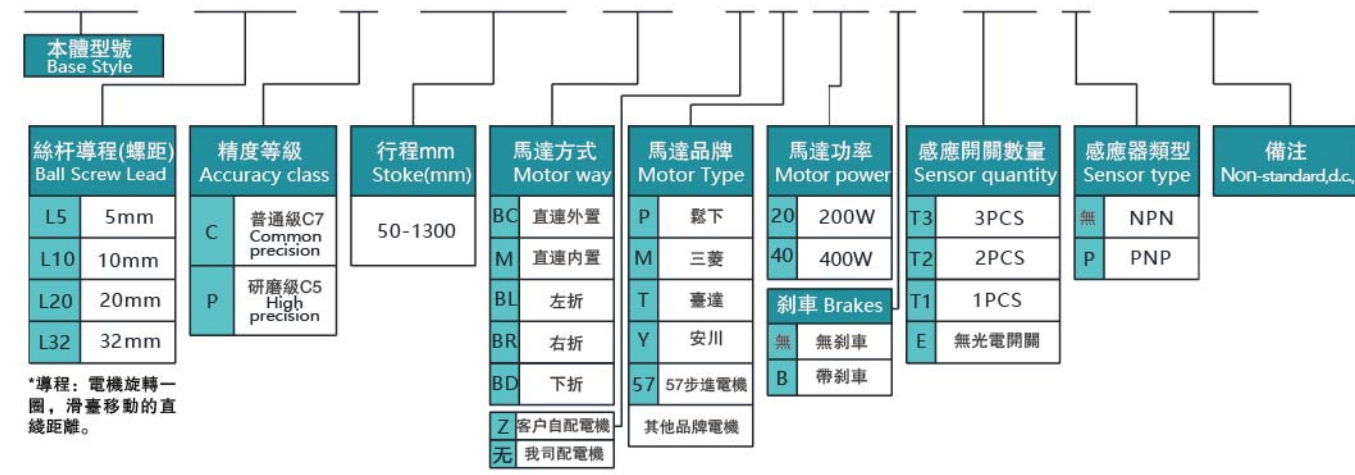

基本型號 Specification

馬達功率(W) Motor Output(W)	400W			
馬達轉速(rpm/mim) Motor Speed(rpm/mim)	*3000			
滾珠絲杆導程-螺距(mm) Belt Lead(mm)	5	10	20	32
最高速度(mm/s)Maximum Payload(mm/s)	250	500	1000	1600
最大負載 Rated load(kg)	水平使用Horizontal	110	88	40
	垂直使用 Vertical	33	25	10
額定推力 Rated thrust(n)	1388	694	347	218
行程範圍 Range of travel(mm)	50-1100MM/50行程遞增			
絲杆外徑 Screw diameter(mm)	φ20 φ16		φ16	
重復位置精度 Repeatability(mm)	C7(C)	±0.01		
	C5(P)	±0.006		
導軌規格 Guide specification	W15XH12-2支			
聯軸器 coupling	10X14(11)*			
感應器 sensor	EE-SX674(NPN)			

*馬達加減速度時間為0.2S
motor speed is 0.2S.

*標配絲杆φ16, 也可定制φ20。

*使用鬆下200W電機時聯軸器為10X11, 其他品牌為10X14。

*如有特殊行程請先與技術人員聯系。

in case special stroke please contact technical services.

安裝示意圖 Installation Instrations&Dimentions

安裝方式:
安裝螺絲從下往上安裝
method 1
fix the screw from bottom to up direction

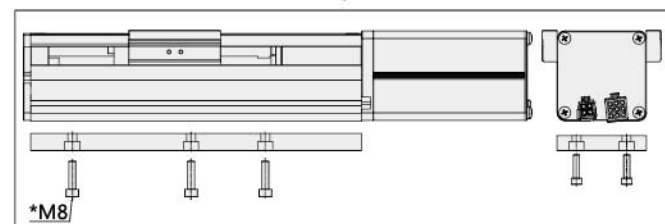

傳感器接綫圖 Sensor Wiring diagram

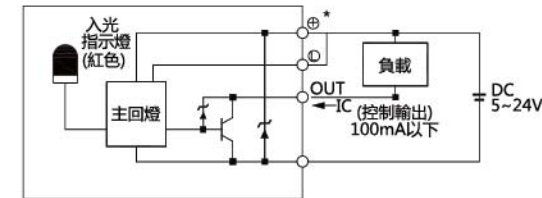

速度與行程 Speed and stroke

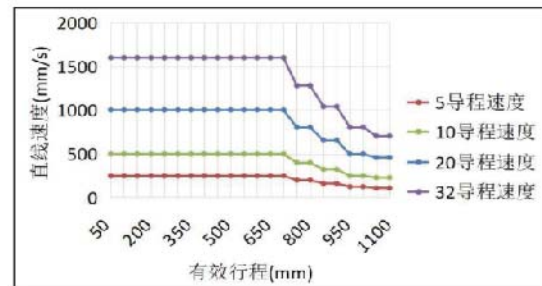

*行程超過750時, 絲杆旋轉會產生共振, 此時請將速度調低。

When the stroke is more than 500, the rotation of the screw will cause resonance, and then the speed will be lowered

靜態力矩表 Static torque gauge

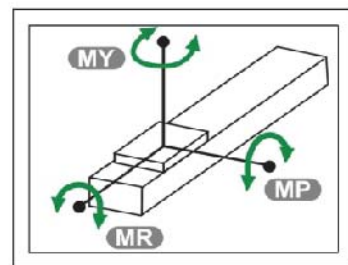

MY	551 (N.M)
MP	552 (N.M)
MR	485 (N.M)

馬達直接外置-BC Motor Exposed

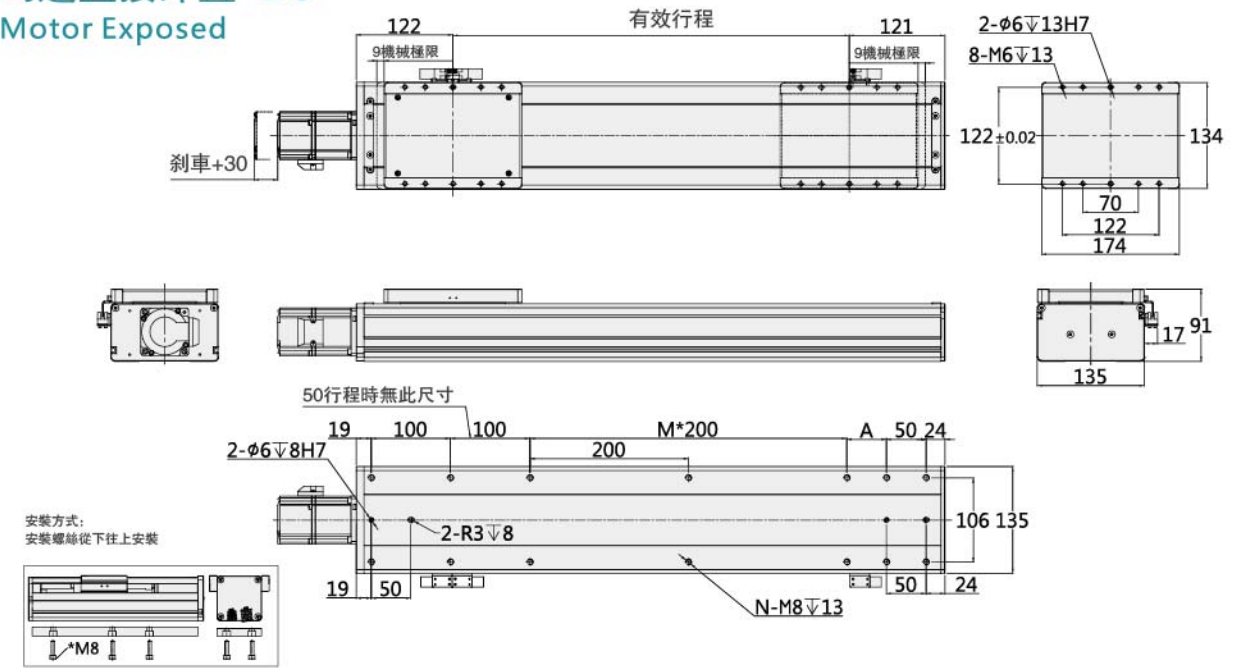

有效行程	50	100	150	200	250	300	350	400	450	500	550	600	650	700	750	800	850	900	950	1000	1050	1100	1150	1200	1250	1300
L	293	343	393	443	493	543	593	643	693	743	793	843	893	943	993	1043	1093	1143	1193	1243	1293	1343	1393	1443	1493	1543
A	0	0	0	0	0	50	100	150	200	50	100	150	200	50	100	150	200	50	100	150	200	50	100	150	200	50
M	0	0	0	0	0	1	1	1	1	2	2	2	2	3	3	3	3	4	4	4	4	5	5	5	5	6
N	8	10	10	10	10	12	12	12	12	14	14	14	14	16	16	16	16	18	18	18	18	20	20	20	20	22
KG	6.2	6.6	7.1	7.5	7.9	8.3	8.8	9.2	9.6	10.1	10.5	10.9	11.3	11.8	12.2	12.6	13.1	13.5	13.9	14.4	14.8	15.2	15.6	16.1	16.5	16.9

注: 以上不含電機重量。Note: Not including motor weight.

如有特殊行程請先與技術人員聯系。in case special stroke please contact technical services.

馬達直接內置-M Motor built-in

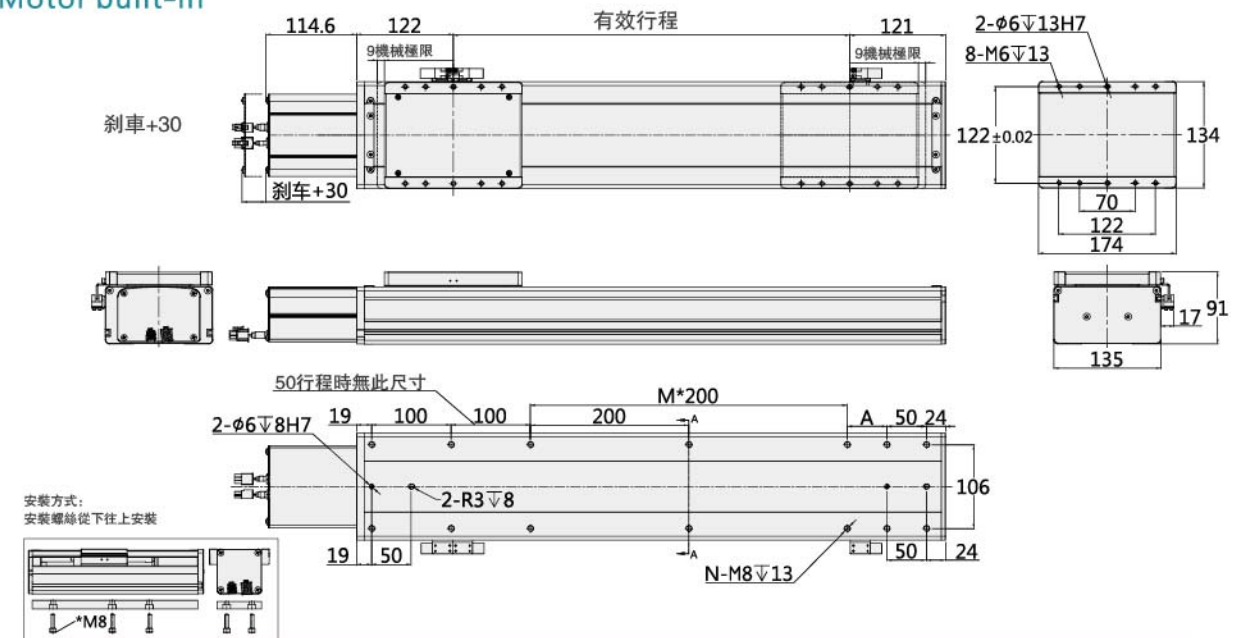

有效行程	50	100	150	200	250	300	350	400	450	500	550	600	650	700	750	800	850	900	950	1000	1050	1100	1150	1200	1250	1300
L	293	343	393	443	493	543	593	643	693	743	793	843	893	943	993	1043	1093	1143	1193	1243	1293	1343	1393	1443	1493	1543
A	0	0	0	0	0	50	100	150	200	50	100	150	200	50	100	150	200	50	100	150	200	50	100	150	200	50
M	0	0	0	0	0	1	1	1	1	2	2	2	2	3	3	3	3	4	4	4	4	5	5	5	5	6
N	8	10	10	10	10	12	12	12	12	14	14	14	14	16	16	16	16	18	18	18	18	20	20	20	20	22
KG	6.4	6.8	7.3	7.7	8.1	8.5	9.0	9.4	9.8	10.3	10.7	11.1	11.6	12.0	12.4	12.8	13.3	13.7	14.1	14.6	15.0	15.4	15.8	16.3	16.7	17.1

注: 以上不含電機重量。Note: Not including motor weight.

如有特殊行程請先與技術人員聯系。in case special stroke please contact technical services.

馬達左折-BL Motor Left Side

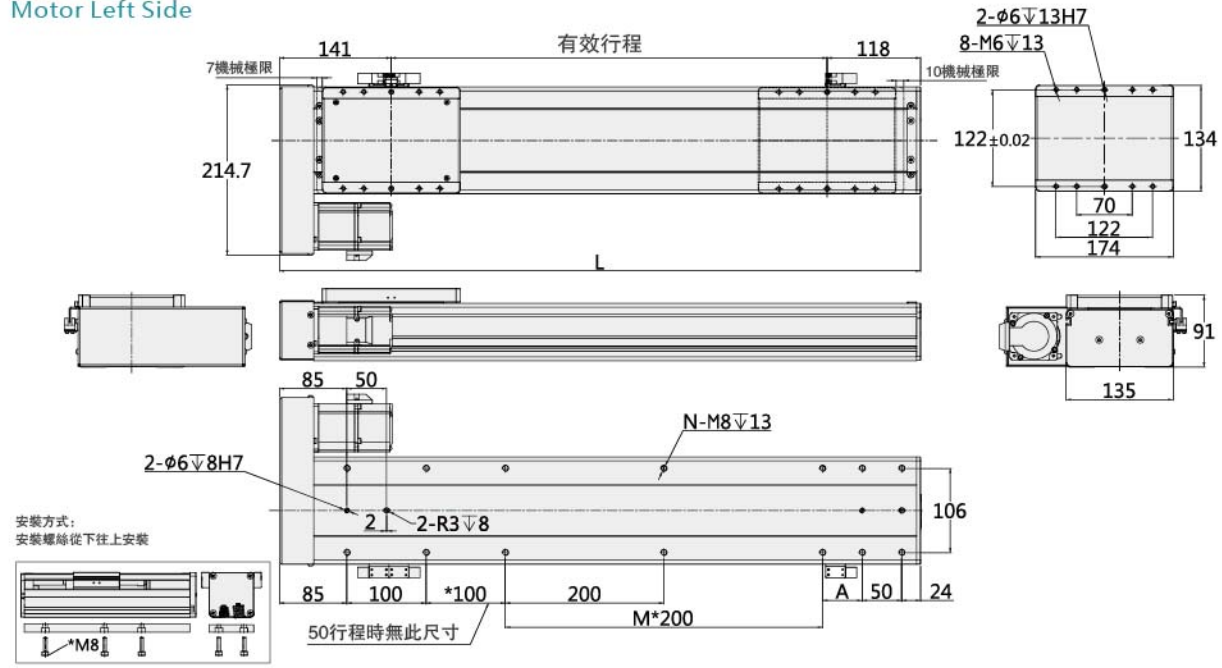

有效行程	50	100	150	200	250	300	350	400	450	500	550	600	650	700	750	800	850	900	950	1000	1050	1100	1150	1200	1250	1300
L	309	359	409	459	509	559	609	659	709	759	809	859	909	959	1009	1059	1109	1159	1209	1259	1309	1359	1409	1459	1509	1559
A	0	0	0	0	0	0	50	100	150	200	50	100	150	200	50	100	150	200	50	100	150	200	50	100	150	200
M	0	0	0	0	0	0	1	1	1	1	2	2	2	2	3	3	3	3	4	4	4	4	5	5	5	5
N	8	8	10	10	10	10	12	12	12	12	14	14	14	14	16	16	16	16	18	18	18	18	18	20	20	20
KG	7.0	7.5	7.9	8.3	8.7	9.2	9.6	10.0	10.5	10.9	11.3	11.8	12.2	12.6	13.0	13.5	13.9	14.3	14.8	15.2	15.6	16.1	16.5	16.9	17.3	17.8

注：以上不含電機重量。Note: Not including motor weight.
如有特殊行程請先與技術人員聯繫。in case special stroke please contact technical services.

馬達下折-BD Motor Bottom Side

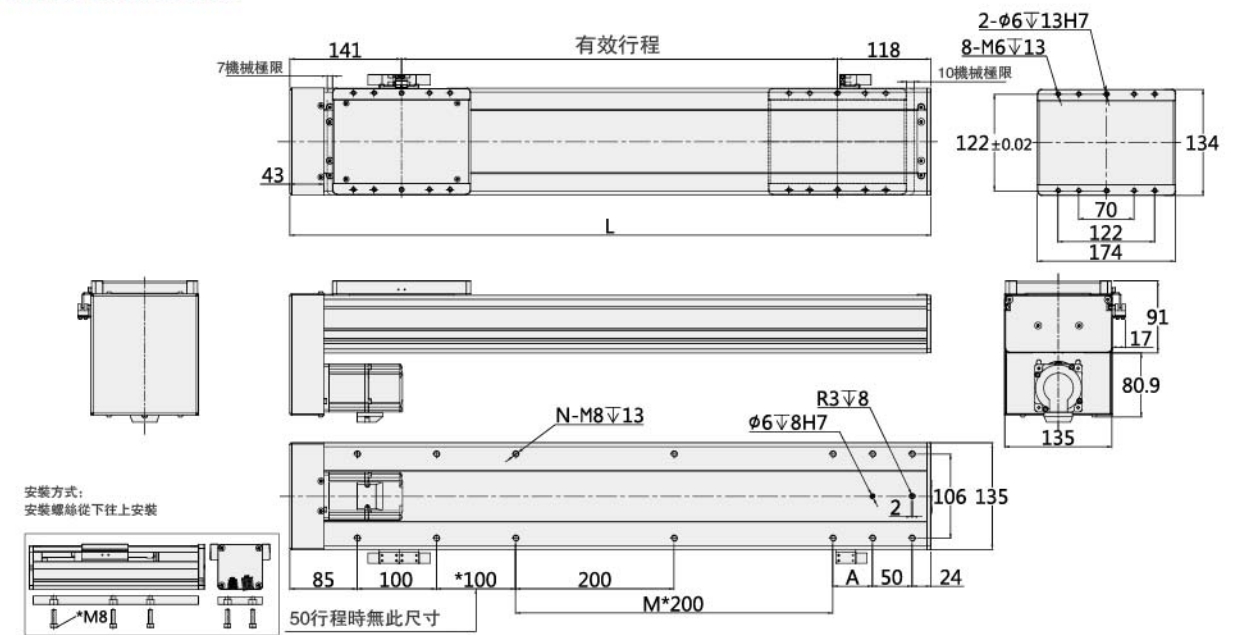

有效行程	50	100	150	200	250	300	350	400	450	500	550	600	650	700	750	800	850	900	950	1000	1050	1100	1150	1200	1250	1300
L	309	359	409	459	509	559	609	659	709	759	809	859	909	959	1009	1059	1109	1159	1209	1259	1309	1359	1409	1459	1509	1559
A	0	0	0	0	0	0	50	100	150	200	50	100	150	200	50	100	150	200	50	100	150	200	50	100	150	200
M	0	0	0	0	0	0	1	1	1	1	2	2	2	2	3	3	3	3	4	4	4	4	5	5	5	5
N	8	8	10	10	10	10	12	12	12	12	14	14	14	14	16	16	16	16	18	18	18	18	20	20	20	20
KG	7.0	7.5	7.9	8.3	8.7	9.2	9.6	10.0	10.5	10.9	11.3	11.8	12.2	12.6	13.0	13.5	13.9	14.3	14.8	15.2	15.6	16.1	16.5	16.9	17.3	17.8

注：以上不含電機重量。Note: Not including motor weight.
如有特殊行程請先與技術人員聯繫。in case special stroke please contact technical services.

馬達右折-BR Motor Right Side

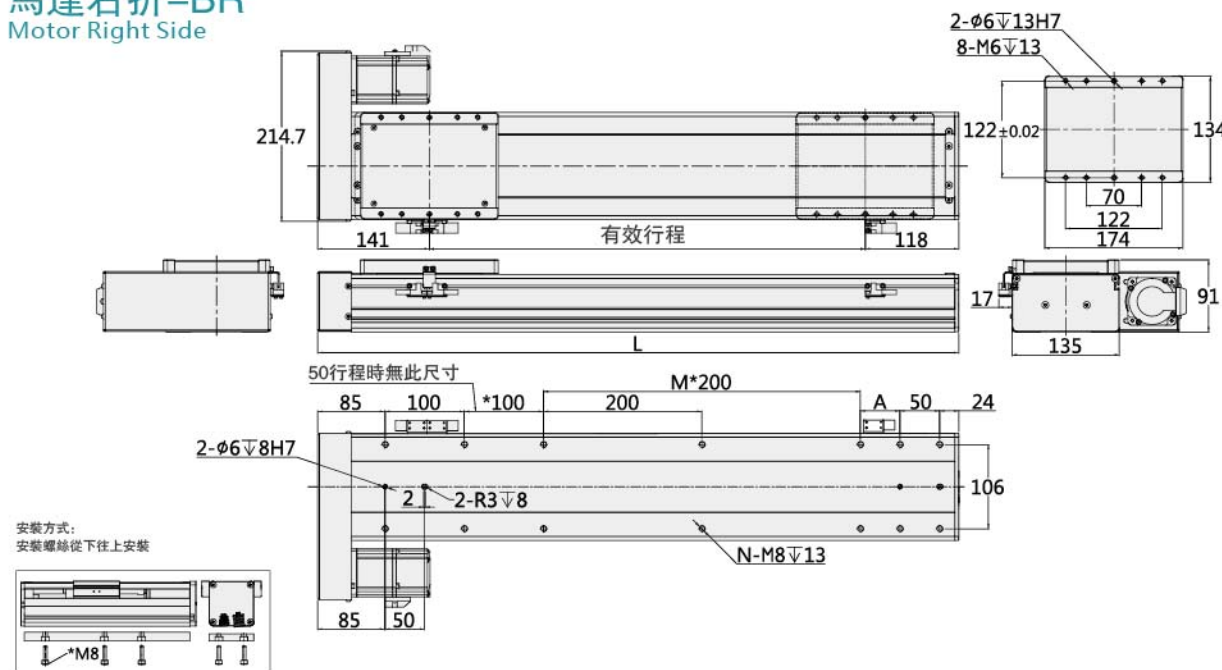

有效行程	50	100	150	200	250	300	350	400	450	500	550	600	650	700	750	800	850	900	950	1000	1050	1100	1150	1200	1250	1300
L	309	359	409	459	509	559	609	659	709	759	809	859	909	959	1009	1059	1109	1159	1209	1259	1309	1359	1409	1459	1509	1559
A	0	0	0	0	0	0	50	100	150	200	50	100	150	200	50	100	150	200	50	100	150	200	50	100	150	200
M	0	0	0	0	0	0	1	1	1	1	2	2	2	2	3	3	3	3	4	4	4	4	5	5	5	5
N	8	8	10	10	10	10	12	12	12	12	14	14	14	14	16	16	16	16	18	18	18	18	20	20	20	20
KG	7.0	7.5	7.9	8.3	8.7	9.2	9.6	10.0	10.5	10.9	11.3	11.8	12.2	12.6	13.0	13.5	13.9	14.3	14.8	15.2	15.6	16.1	16.5	16.9	17.3	17.8

注：以上不含電機重量。Note: Not including motor weight.
如有特殊行程請先與技術人員聯繫。in case special stroke please contact technical services.

密封式絲杆滑臺-LEC17

SEALED SCREW SLIDE



基本型號 Specification

馬達功率(W) Motor Output(W)	400W/750				
馬達轉速(rpm/mim) Motor Speed(rpm/mim)	*3000				
滾珠絲杆導程-螺距(mm) Belt Lead(mm)	5	10	20	40	
最高速度(mm/s) Maximum Payload(mm/s)	250	500	1000	1600	
最大負載 Rated load(kg)	水平使用Horizontal	120	110/120	75/83	22/43
	垂直使用 Vertical	40/50	30/40	14/25	7/12
額定推力 Rated thrust(n)	1388/2553	694/1281	347/640	174/320	
行程範圍 Range of travel(mm)	50-1400MM/50行程遞增				
絲杆外徑 Screw diameter(mm)	φ20φ25		φ20		
重複位置精度 Repeatability(mm)	C7(C)	±0.01			
	C5(P)	±0.006			
導軌規格 Guide specification	W20XH15-2支				
聯軸器 coupling	12X14(400W)/12X19(750W)				
感應器 sensor	EE-SX674(NPN)				

*馬達加減速度時間為0.2S
motor speed is 0.2S.

*標配絲杆φ20, 也可定制φ25。

*如有特殊行程請先與技術人員聯系。

in case special stroke please contact technical services.

傳感器接綫圖 Sensor Wiring diagram

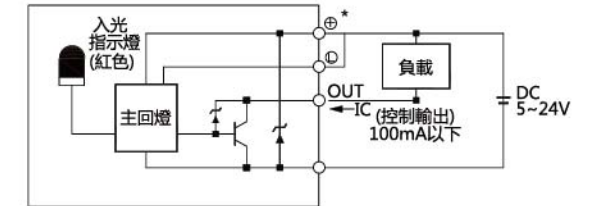

速度與行程 Speed and stroke

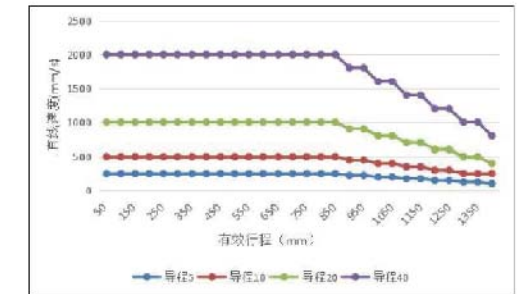

*行程超過850時, 絲杆旋轉會產生共振, 此時請將速度調低。

When the stroke is more than 500, the rotation of the screw will cause resonance, and then the speed will be lowered

馬達安裝方式 Motor direction

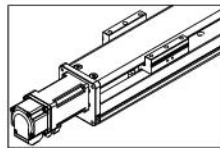

馬達直連外置-BC
Motor Exposed

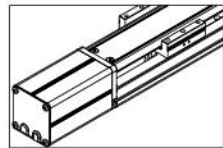

馬達直連內置-M
Motor built-in

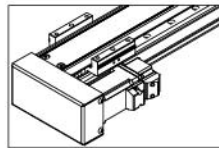

馬達左折-BL
Motor Left Side

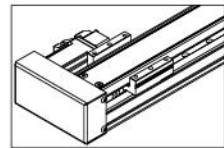

馬達右折-BR
Motor Right Side

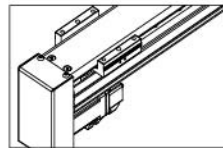

馬達下折-BD
Motor Bottom Side

型號表示方式 Guide for Model Selection

LEC17-L10-C-S100-BC-ZP40B-T3-001

本體型號 Base Style	絲杆導程(螺距) Ball Screw Lead	精度等級 Accuracy class	行程mm Stroke(mm)	馬達方式 Motor way	馬達品牌 Motor Type	馬達功率 Motor power	感應開關數量 Sensor quantity	感應器類型 Sensor type	備註 Non-standard, d.c.
	L5 5mm	C 普通級C7 Common precision	50-1400	BC 直連外置	P 聯下	40 400W	T3 3PCS	無 NPN	
	L10 10mm	P 研磨級C5 High precision		M 直連內置	M 三菱	75 750W	T2 2PCS	P PNP	
	L20 20mm			BL 左折	T 臺達	86 86步進	T1 1PCS		
	L40 40mm			BR 右折	Y 安川		E 無光電開關		
				BD 下折	86 86步進電機				
				Z 客戶自配電機 無 我司配電機	其他品牌電機				
						剎車 Brakes			
						無 無剎車			
						B 帶剎車			

*導程: 電機旋轉一圈, 滑臺移動的直綫距離。

安裝示意圖 Installation Instrations&Dimentions

安裝方式:
安裝螺絲從下往上安裝
method 1
fix the screw from bottom to up direction

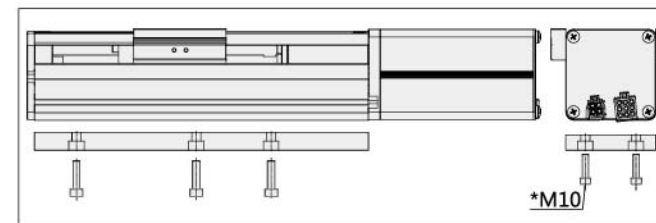

靜態力矩表 Static torque gauge

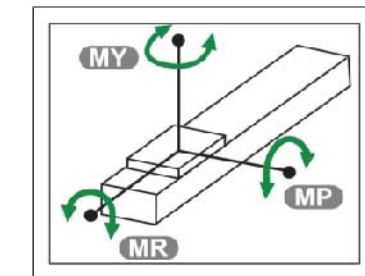

MY	1032 (N.M)
MP	1034 (N.M)
MR	908 (N.M)

馬達直接外置-BC Motor Exposed

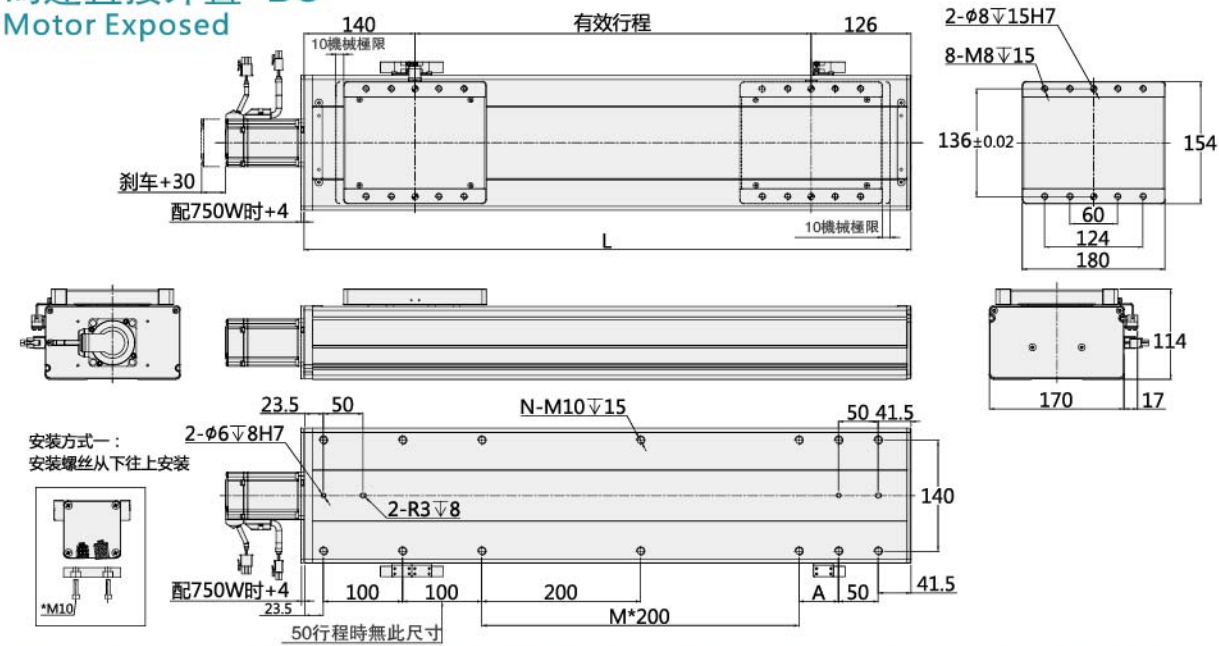

有效行程	50	100	150	200	250	300	350	400	450	500	550	600	650	700	750	800	850	900	950	1000	1050	1100	1150	1200	1250	1300	1350	1400
L	316	366	416	466	516	566	616	666	716	766	816	866	916	966	1016	1066	1116	1166	1216	1266	1316	1366	1416	1466	1516	1566	1616	1666
A	0	0	0	0	0	50	100	150	200	50	100	150	200	50	100	150	200	50	100	150	200	50	200	50	100	150	200	50
M	0	0	0	0	0	1	1	1	1	2	2	2	2	3	3	3	3	4	4	4	4	5	5	5	5	6	6	6
N	8	10	10	10	10	12	12	12	12	14	14	14	14	16	16	16	16	18	18	18	18	20	20	20	20	22	22	22
KG	8.8	9.6	10.4	11.1	11.9	12.7	13.5	14.3	15.1	15.9	16.7	17.5	18.3	19	19.8	20.6	21.4	22.2	23	23.8	24.6	25.4	26.2	27	27.8	28.5	29.3	30

注：以上不含電機重量。Note: Not including motor weight.
如有特殊行程請先與技術人員聯繫。in case special stroke please contact technical services.

馬達左折-BL Motor Left Side

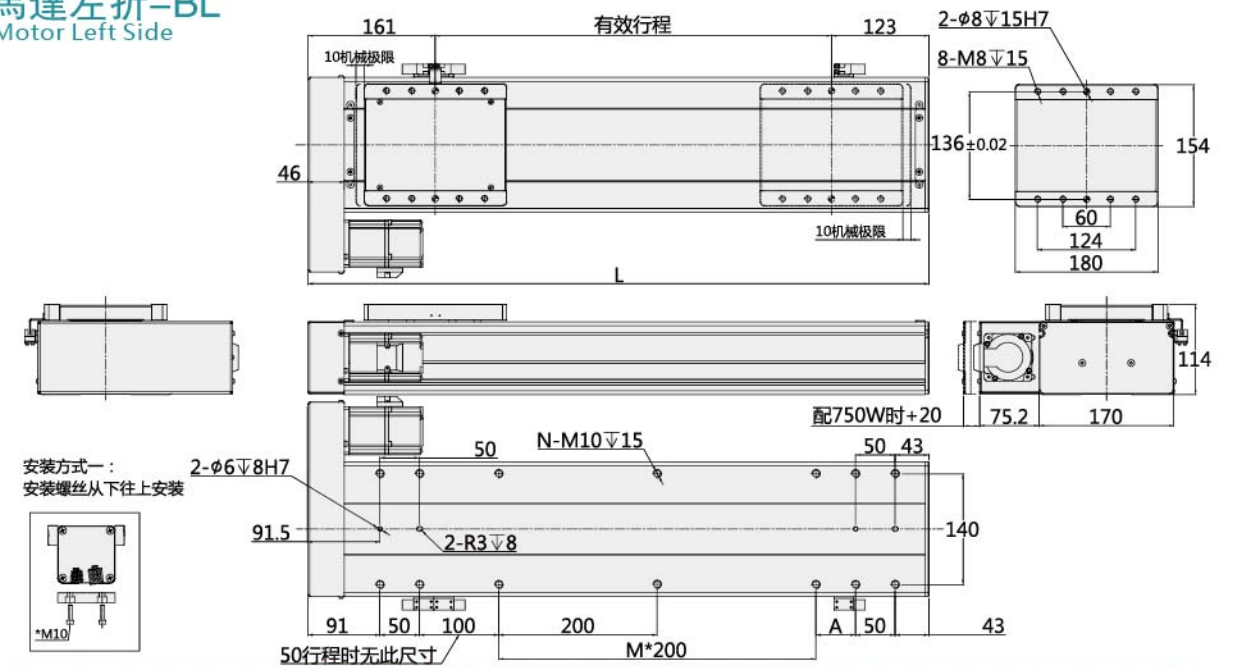

有效行程	50	100	150	200	250	300	350	400	450	500	550	600	650	700	750	800	850	900	950	1000	1050	1100	1150	1200	1250	1300	1350	1400
L	334	384	434	484	534	584	634	684	734	784	834	884	934	984	1034	1084	1134	1184	1234	1284	1334	1384	1434	1484	1534	1584	1634	1684
A	0	0	0	0	0	50	100	150	200	50	100	150	200	50	100	150	200	50	100	150	200	50	200	50	100	150	200	50
M	0	0	0	0	0	1	1	1	1	2	2	2	2	3	3	3	3	4	4	4	4	5	5	5	5	6	6	6
N	8	10	10	10	10	12	12	12	12	14	14	14	14	16	16	16	16	18	18	18	18	20	20	20	20	22	22	22
KG	10	10.7	11.5	12.2	13	13.8	14.9	15.4	16.2	17	17.8	18.6	19.4	20.1	20.9	21.7	22.5	23.3	24.1	24.9	25.7	26.5	27.3	28.1	28.9	29.6	30.5	31.2

注：以上不含電機重量。Note: Not including motor weight.
如有特殊行程請先與技術人員聯繫。in case special stroke please contact technical services.

馬達直接內置-M Motor built-in

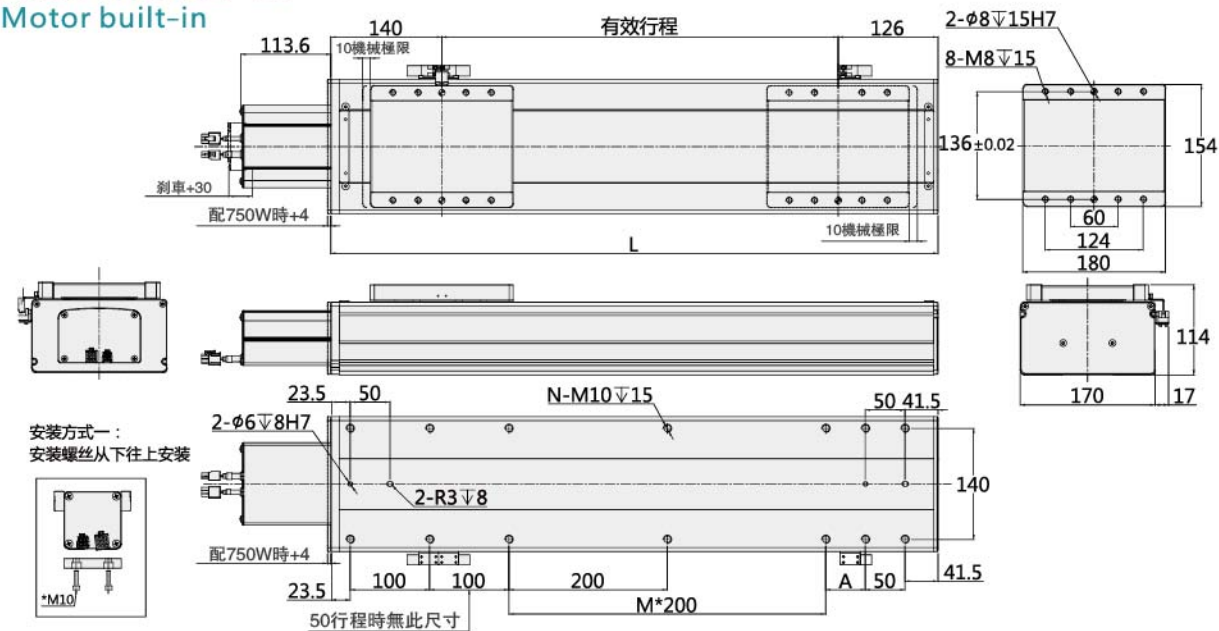

有效行程	50	100	150	200	250	300	350	400	450	500	550	600	650	700	750	800	850	900	950	1000	1050	1100	1150	1200	1250	1300	1350	1400
L	316	366	416	466	516	566	616	666	716	766	816	866	916	966	1016	1066	1116	1166	1216	1266	1316	1366	1416	1466	1516	1566	1616	1666
A	0	0	0	0	0	50	100	150	200	50	100	150	200	50	100	150	200	50	100	150	200	50	200	50	100	150	200	50
M	0	0	0	0	0	1	1	1	1	2	2	2	2	3	3	3	3	4	4	4	4	5	5	5	5	6	6	6
N	8	10	10	10	10	12	12	12	12	14	14	14	14	16	16	16	16	18	18	18	18	20	20	20	20	22	22	22
KG	8.8	9.6	10.4	11.1	11.9	12.7	13.5	14.3	15.1	15.9	16.7	17.5	18.3	19	19.8	20.6	21.4	22.2	23	23.8	24.6	25.4	26.2	27	27.8	28.5	29.3	30

注：以上不含電機重量。Note: Not including motor weight.
如有特殊行程請先與技術人員聯繫。in case special stroke please contact technical services.

馬達右折-BR Motor Right Side

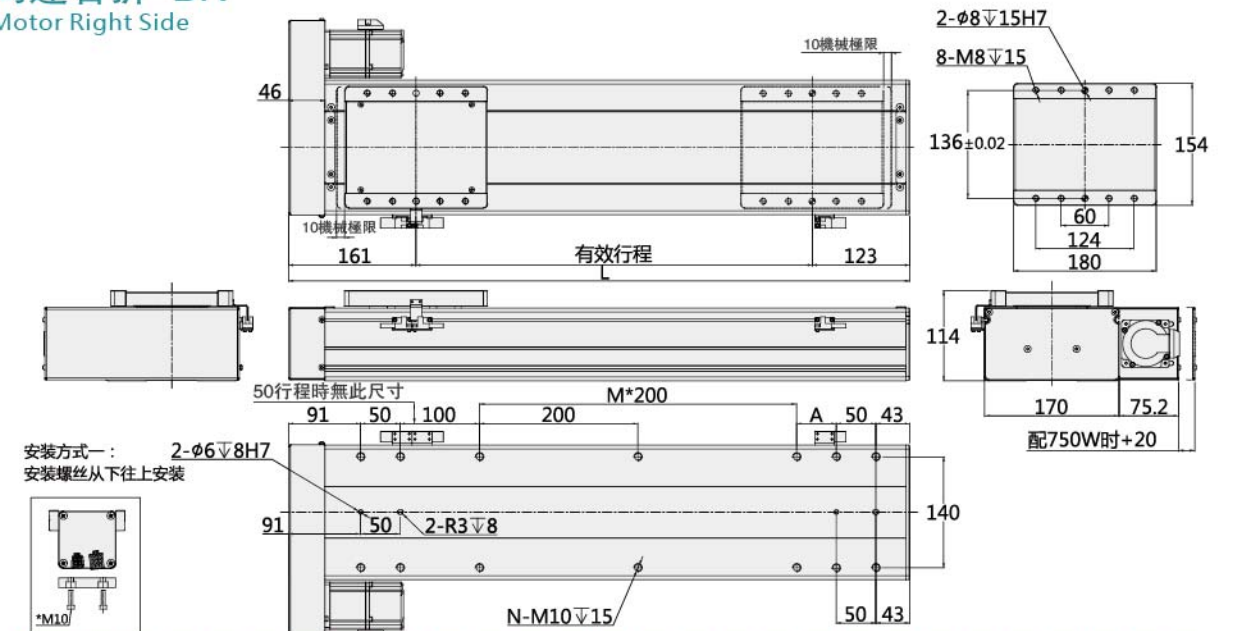

有效行程	50	100	150	200	250	300	350	400	450	500	550	600	650	700	750	800	850	900	950	1000	1050	1100	1150	1200	1250	1300	1350	1400
L	334	384	434	484	534	584	634	684	734	784	834	884	934	984	1034	1084	1134	1184	1234	1284	1334	1384	1434	1484	1534	1584	1634	1684
A	0	0	0	0	0	50	100	150	200	50	100	150	200	50	100	150	200	50	100	150	200	50	200	50	100	150	200	50
M	0	0	0	0	0	1	1	1	1	2	2	2	2	3	3	3	3	4	4	4	4	5	5	5	5	6	6	6
N	8	10	10	10	10	12	12	12	12	14	14	14	14	16	16	16	16	18	18	18	18	20	20	20	20	22	22	22
KG	10	10.7	11.5	12.2	13	13.8	14.9	15.4	16.2	17	17.8	18.6	19.4	20.1	20.9	21.7	22.5	23.3	24.1	24.9	25.7	26.5	27.3	28.1	28.9	29.6	30.5	31.2

注：以上不含電機重量。Note: Not including motor weight.
如有特殊行程請先與技術人員聯繫。in case special stroke please contact technical services.

馬達下折-BD
Motor Bottom Side

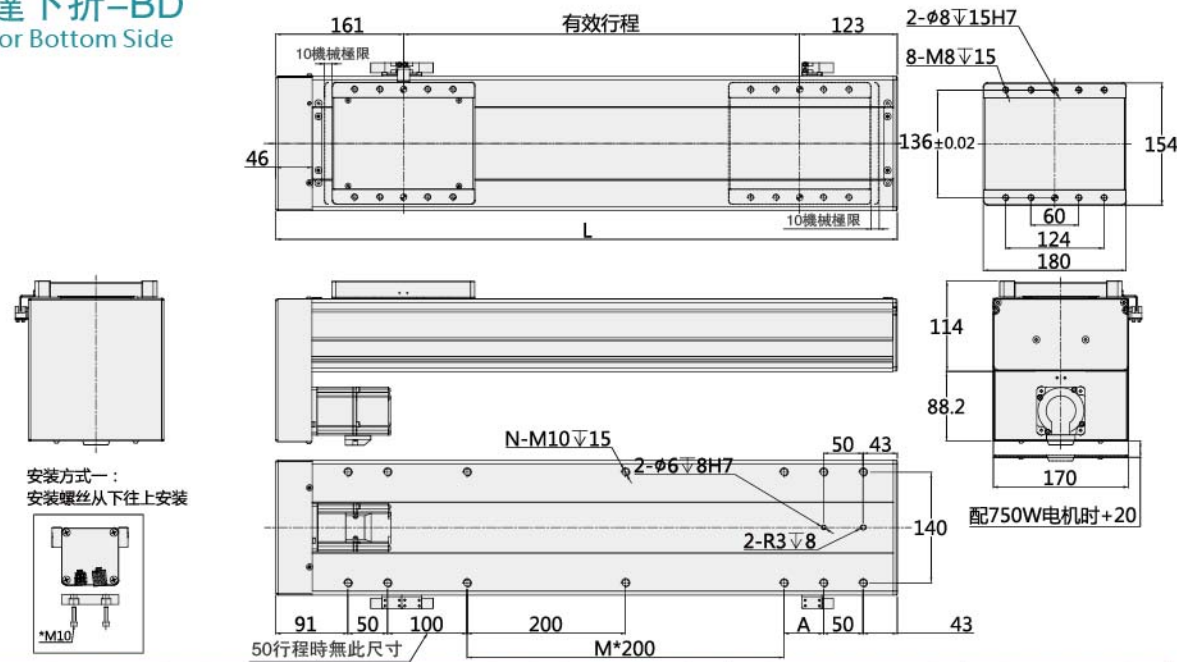

有效行程	50	100	150	200	250	300	350	400	450	500	550	600	650	700	750	800	850	900	950	1000	1050	1100	1150	1200	1250	1300	1350	1400
L	334	384	434	484	534	584	634	684	734	784	834	884	934	984	1034	1084	1134	1184	1234	1284	1334	1384	1434	1484	1534	1584	1634	1684
A	0	0	0	0	0	50	100	150	200	50	100	150	200	50	100	150	200	50	100	150	200	50	200	50	100	150	200	50
M	0	0	0	0	0	1	1	1	1	2	2	2	2	3	3	3	3	4	4	4	4	5	5	5	5	6	6	6
N	8	10	10	10	10	12	12	12	12	14	14	14	14	16	16	16	16	18	18	18	18	20	20	20	20	22	22	22
KG	10.2	10.9	11.7	12.9	13.2	14	15.1	15.6	16.4	17.2	18	18.8	19.8	20.3	21.2	21.9	22.7	23.5	24.3	25.1	25.9	26.7	27.5	28.3	29.2	29.8	30.7	31.4

注：以上不含電機重量。Note: Not including motor weight.
如有特殊行程請先與技術人員聯繫。in case special stroke please contact technical services.

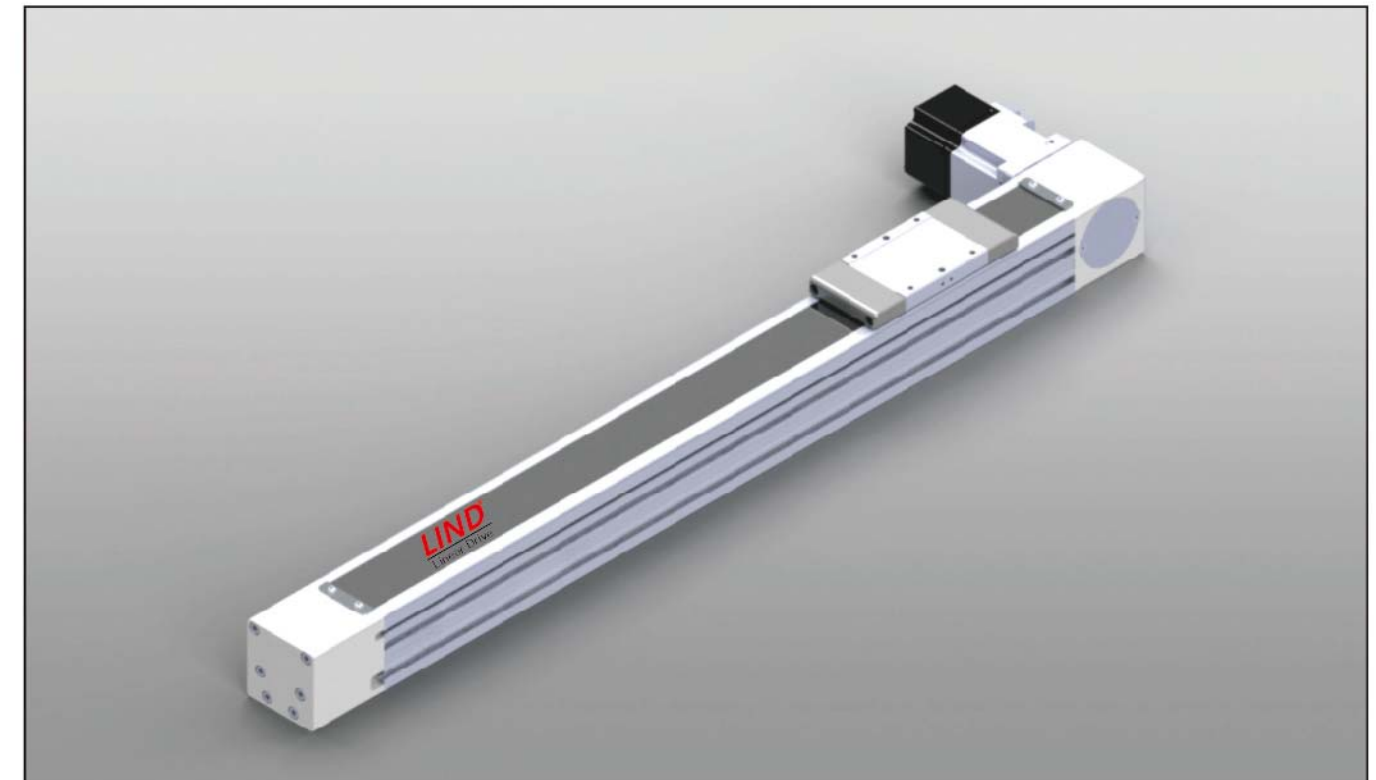

馬達安裝方式 Motor direction

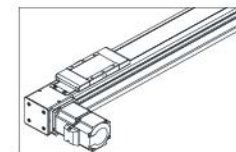

馬達上折-BU
Motor Exposed

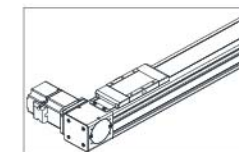

馬達下折-BD
Motor Bottom Side

型號表示方式 Guide for Model Selection

LBC6-L120-S100-L- ZP40B- T3- _ 001

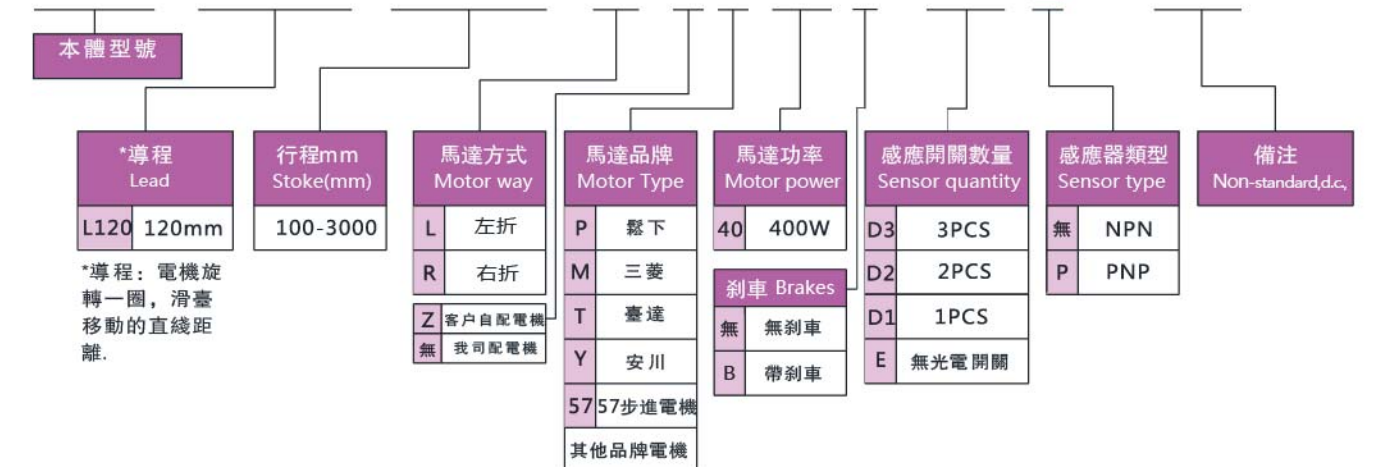

基本型號 Specification

馬達轉速 Motor Speed(rpm/mim)	500	1000	1500	2000	2500	3000
最高速度(mm/s) Maximum Payload(mm/s)	1000	2000	3000	4000	5000	6000
最高負載(水平使用) Rated load(kg)	9	5	3	2	1.5	1
重複位置精度(mm) Repeatability(mm)	±0.05					
*導程(mm) Lead(mm)	120					
額定推力 (N) Rated thrust(n)	65					
行程範圍 Range of travel(mm)	100-3000MM/50行程遞增					
馬達功率 Motor Output(W)	400					
皮帶寬度 Synchro band width(mm)	20					
導軌規格 Guide specification	W15XH12					
感應器 sensor	EE-SX674(NPN)					

*導程:電機旋轉一圈, 滑臺移動的直線距離。

* Guide: the rotation of the motor and the straight distance of the sliding table.

*馬達加減速度時間為0.4S.
motor speed is 0.4S.

*如有特殊行程請先與技術人員聯系。
in case special stroke please contact technical services.

安裝示意圖 Installation Instrations&Dimentions

安裝方式一:
安裝螺絲從下往上安裝
method 1
fix the screw from bottom to up direction

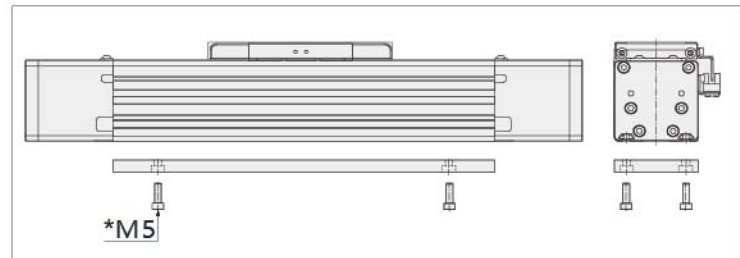

安裝方式二:
通過安裝壓塊, 安裝螺絲從上往下安裝
method 2
Install screw from top to bottom by installing press block

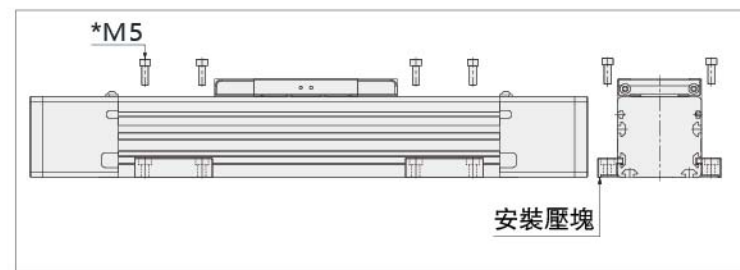

傳感器接綫圖 Sensor Wiring diagram

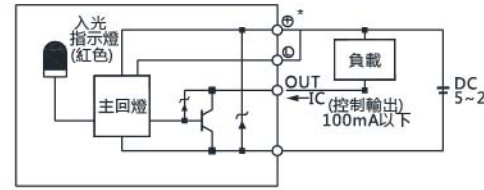

速度與行程 Speed and stroke

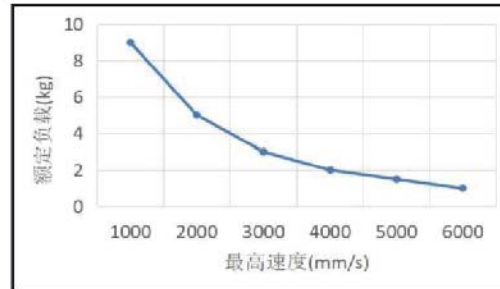

靜態力矩表 Static torque gauge

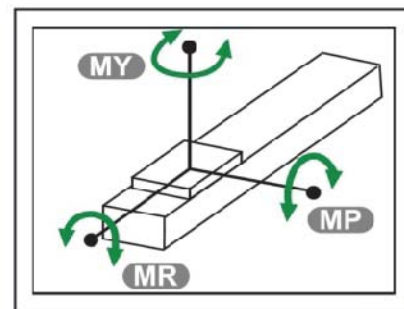

MY	44 (N.M)
MP	44 (N.M)
MR	12 (N.M)

馬達左折-L Motor Left Side

有效行程	100	200	300	400	500	600	700	800	900	1000	1100	1200	1300	1400	1500
L	406	506	606	706	806	906	1006	1106	1206	1306	1406	1506	1606	1706	1806
KG	3.7	4.3	4.9	5.5	6.1	6.7	7.4	8	8.6	9.2	9.8	10.4	11	11.7	12.3

有效行程	1600	1700	1800	1900	2000	2100	2200	2300	2400	2500	2600	2700	2800	2900	3000
L	1906	2006	2106	2206	2306	2406	2506	2606	2706	2806	2906	3006	3106	3206	3306
KG	12.9	13.5	14.1	14.8	15.4	16	16.6	17.2	17.8	18.4	19	19.6	20.3	20.9	21.5

注: 以上不含電機重量。Note: Not including motor weight.
如有特殊行程請先與技術人員聯系。in case special stroke please contact technical services.

馬達右折-R Motor Right Side

有效行程	100	200	300	400	500	600	700	800	900	1000	1100	1200	1300	1400	1500
L	406	506	606	706	806	906	1006	1106	1206	1306	1406	1506	1606	1706	1806
KG	3.7	4.3	4.9	5.5	6.1	6.7	7.4	8	8.6	9.2	9.8	10.4	11	11.7	12.3

有效行程	1600	1700	1800	1900	2000	2100	2200	2300	2400	2500	2600	2700	2800	2900	3000
L	1906	2006	2106	2206	2306	2406	2506	2606	2706	2806	2906	3006	3106	3206	3306
KG	12.9	13.5	14.1	14.8	15.4	16	16.6	17.2	17.8	18.4	19	19.6	20.3	20.9	21.5

注: 以上不含電機重量。Note: Not including motor weight.
如有特殊行程請先與技術人員聯系。in case special stroke please contact technical services.

歐規同步帶滑臺-LBC6H

EUCLIDEAN SYNCHRONIZATION BELT SLIDER

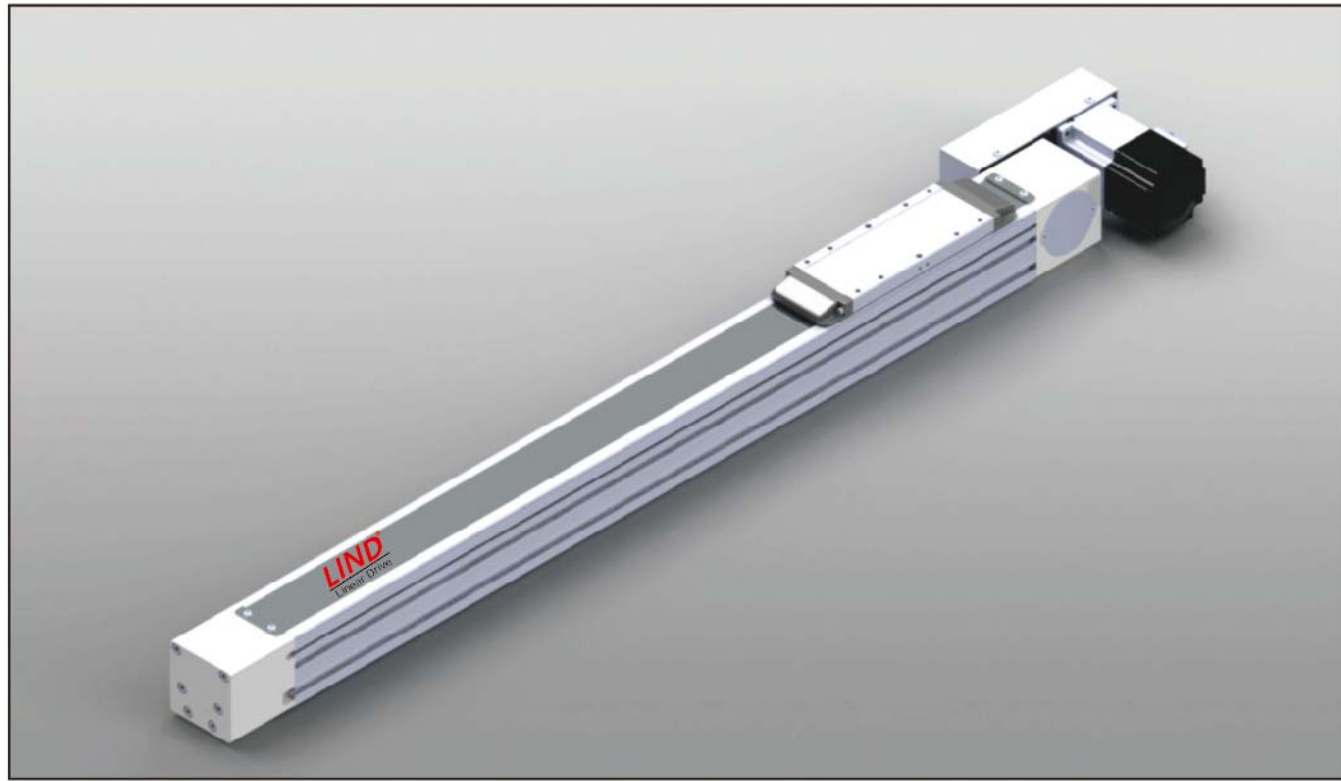

馬達安裝方式 Motor direction

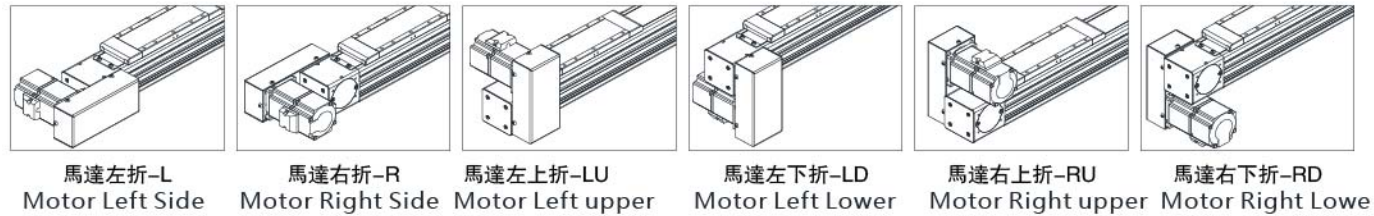

型號表示方式 Guide for Model Selection

LBC6H-L160-S100-L- ZP40B-T3- _ 001

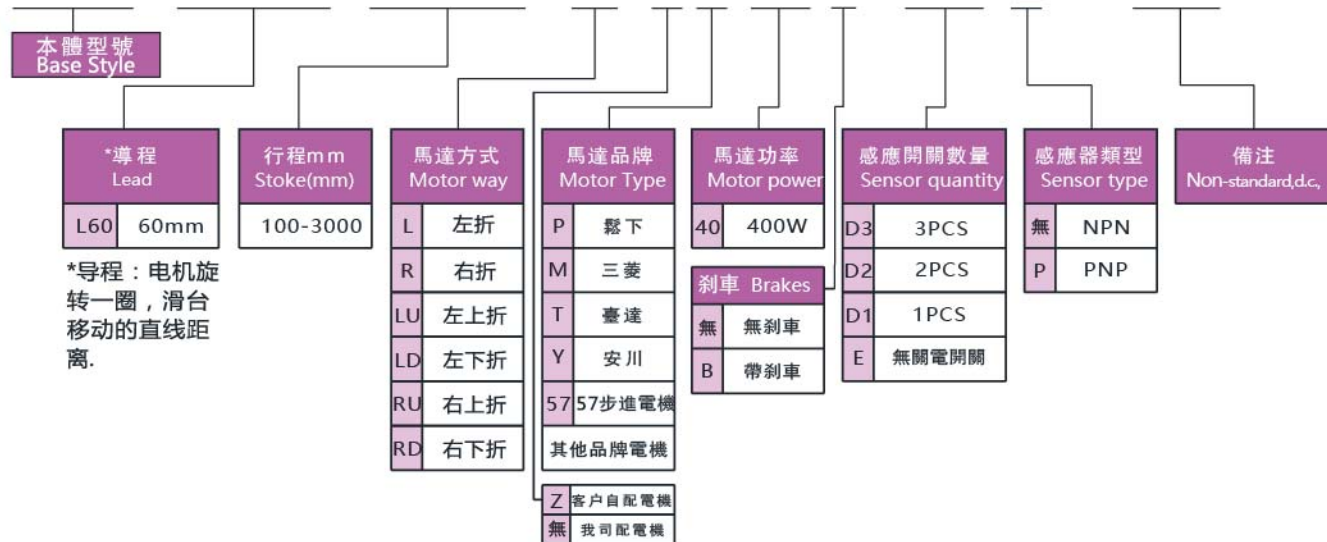

基本型號 Specification

馬達轉速 Motor Speed(rpm/mim)	500 1000 1500 2000 2500 3000
最高速度(mm/s) Maximum Payload(mm/s)	500 1000 1500 2000 2500 3000
最高負載(水平使用) Rated load(kg)	22 14 10 8 6 5
重復位置精度(mm) Repeatability(mm)	±0.05
*導程(mm) Lead(mm)	60
額定推力(N) Rated thrust(N)	122
行程範圍 Range of travel(mm)	100-3000MM/50行程遞增
馬達功率 Motor Output(W)	400
皮帶寬度 Synchro band width(mm)	20
導軌規格 Guide specification	W15XH12
感應器 sensor	EE-SX674(NPN)

*導程:電機旋轉一圈，滑臺移動的直線距離。

* Guide: the rotation of the motor and the straight distance of the sliding table.

*馬達加減速度時間為0.4S.
motor speed is 0.4S.

*如有特殊行程請先與技術人員聯系。

in case special stroke please contact technical services.

安裝示意圖 Installation Instrations&Dimentions

安裝方式一：

安裝螺絲從下往上安裝

method 1

fix the screw from bottom to up direction

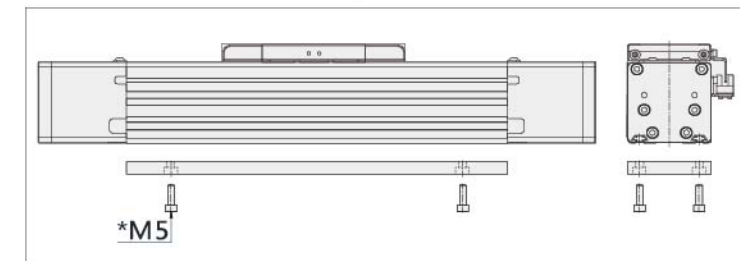

安裝方式二：

通過安裝壓塊，安裝螺絲從上往下安裝

method 2

Install screw from top to bottom by installing press block

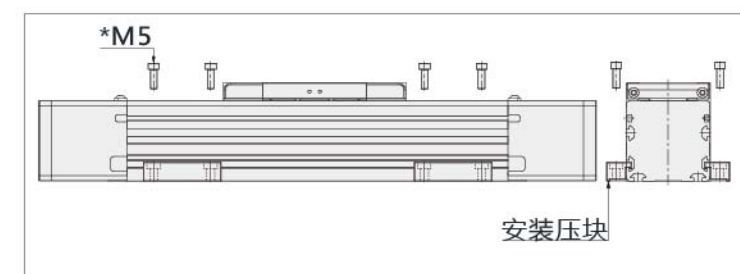

傳感器接綫圖 Sensor Wiring diagram

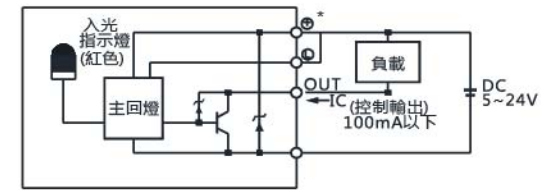

速度與行程 Speed and stroke

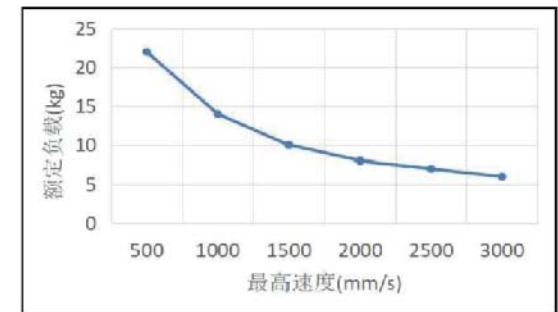

靜態力矩表 Static torque gauge

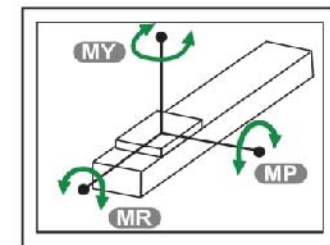

MY	280(N.M)
MP	280(N.M)
MR	60(N.M)

馬達左折-L Motor Left Side

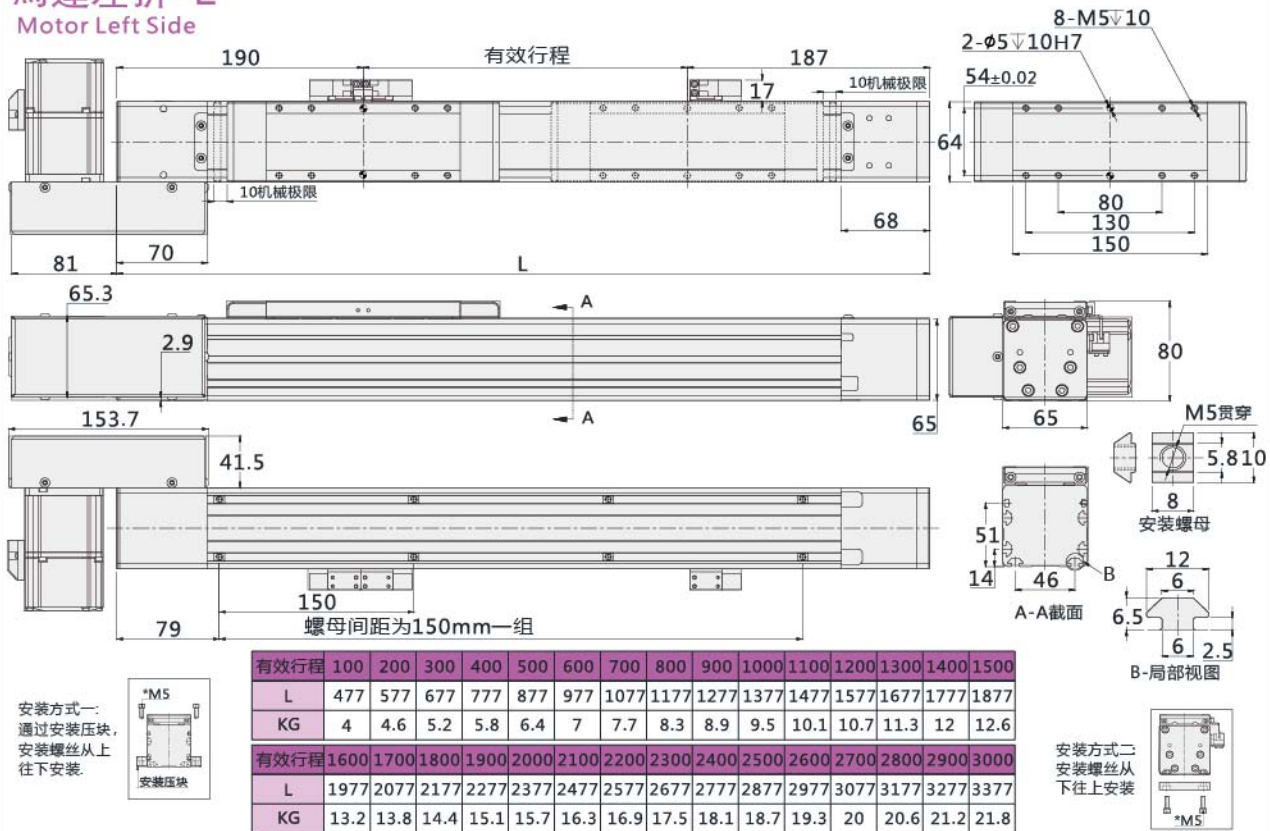

注：以上不含電機重量。Note: Not including motor weight.
如有特殊行程請先與技術人員聯繫。in case special stroke please contact technical services.

馬達左上折-LU Motor Left upper

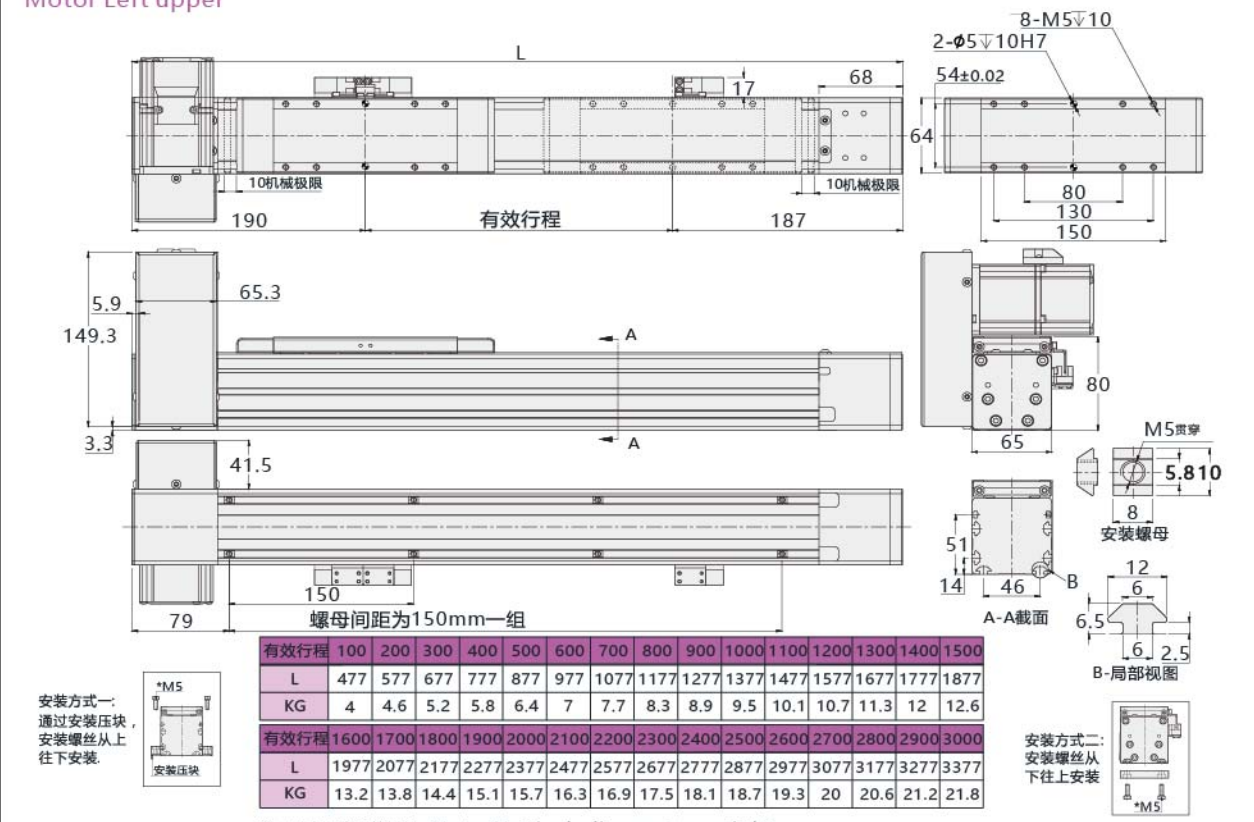

注：以上不含電機重量。Note: Not including motor weight.
如有特殊行程請先與技術人員聯繫。in case special stroke please contact technical services.

馬達右折-R Motor Right Side

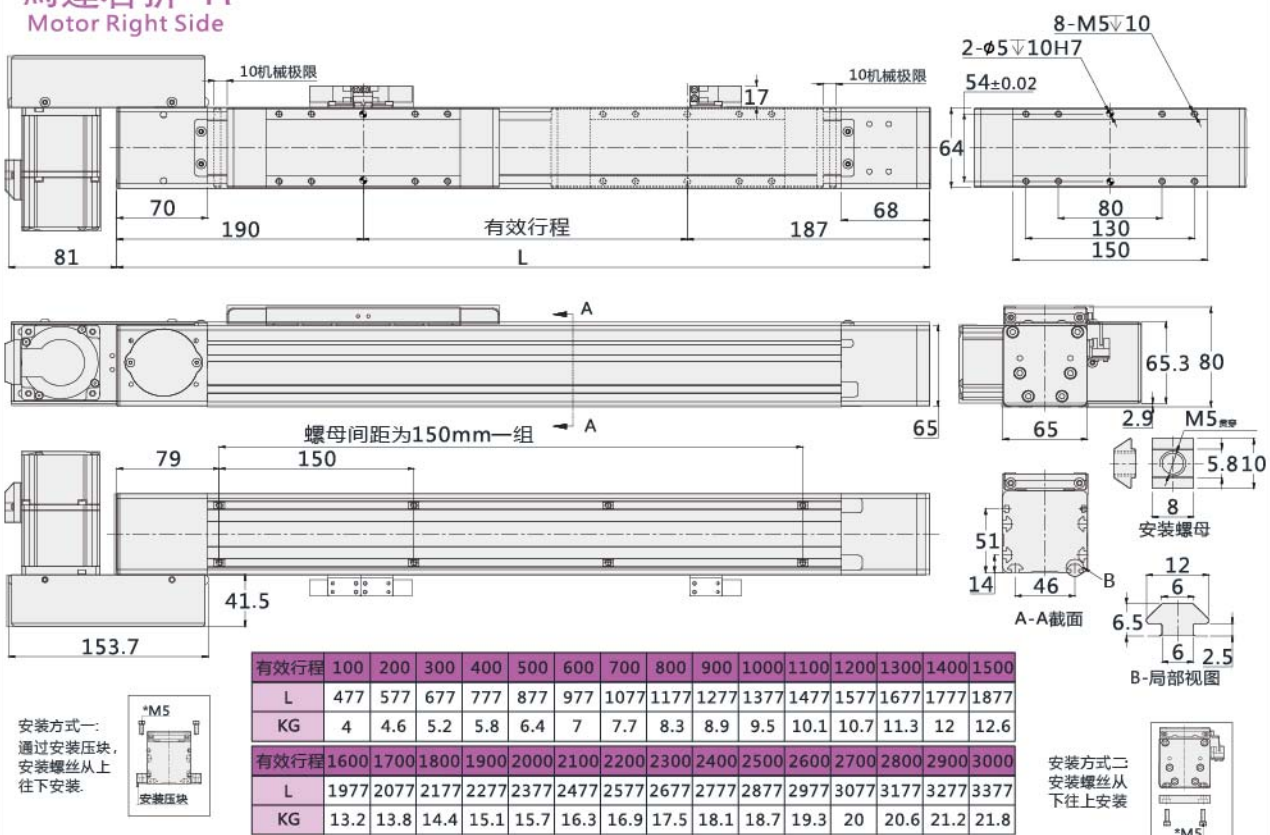

注：以上不含電機重量。Note: Not including motor weight.
如有特殊行程請先與技術人員聯繫。in case special stroke please contact technical services.

馬達左下折-LD Motor Right Side

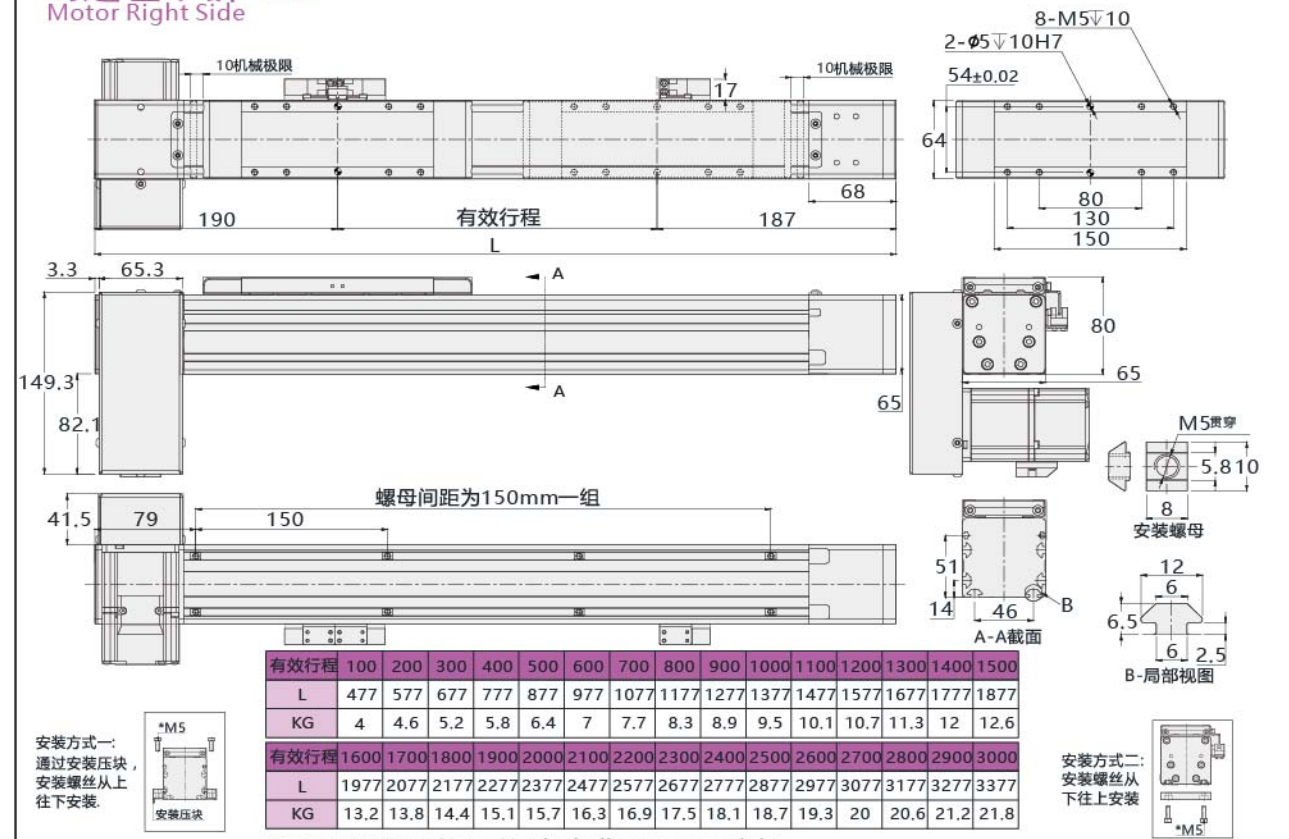

注：以上不含電機重量。Note: Not including motor weight.
如有特殊行程請先與技術人員聯繫。in case special stroke please contact technical services.

基本型號 Specification

馬達轉速(w) Motor Speed(rpm/mim)	400W		750W	
行星減速機 (減速比) Gear reducer	5:1	10:1	5:1	10:1
*導程(mm) Lead(mm)	176/5	176/10	176/5	176/10
最高速度(mm/s) Maximum Payload(mm/s)	1760	880	1760	880
最大負載 (水平使用) Rated load	25	50	50	80
最大負載 (垂直使用) Rated load	10	20	18	38
額定推力 (N) Rated thrust(N)	208	416	385	770
行程範圍 Range of travel(mm)	100-3000MM/50行程遞增			
重複位置精度(mm) Repeatability(mm)	±0.05			
皮帶寬度(mm) Synchro band width(mm)	30(S8M)			
導軌規格(mm) Guide specification	W20XH15.5			
感應器 sensor	EE-SX674(NPN)			

*導程:電機旋轉一圈, 滑臺移動的直綫距離。

* Guide: the rotation of the motor and the straight distance of the sliding table.

*馬達加減速度時間為0.4S.
motor speed is 0.4S.

*如有特殊行程請先與技術人員聯系。

in case special stroke please contact technical services.

安裝示意圖 Installation Instratons&Dimentions

安裝方式一:

安裝螺絲從下往上安裝

method 1

fix the screw from bottom to up direction

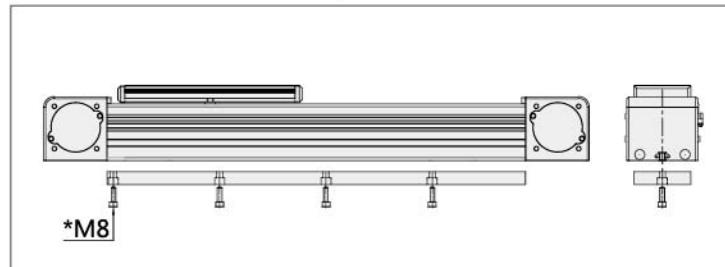

安裝方式二:

通過安裝壓塊, 安裝螺絲從上往下安裝。

method 2

Install screw from top to bottom by installing press block

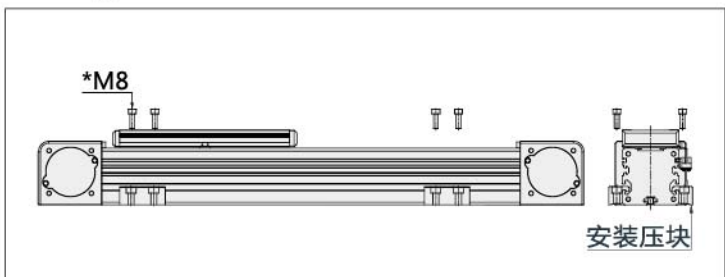

傳感器接綫圖 Sensor Wiring diagram

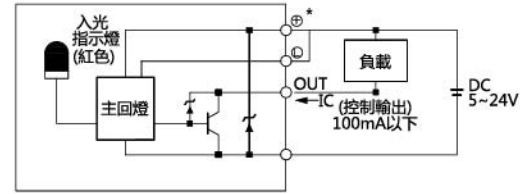

馬達左折-L Motor Left Side

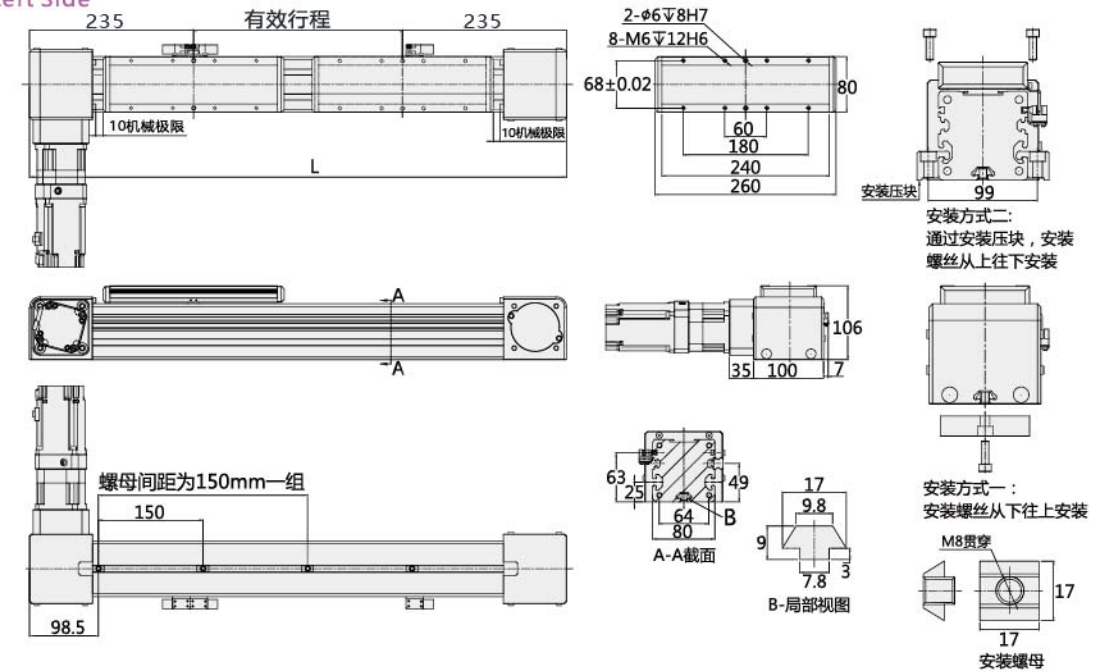

有效行程	100	200	300	400	500	600	700	800	900	1000	1100	1200	1300	1400	1500	1600	1700	1800	1900	2000	2100	2200	2300	2400	2500	2600	2700	2800	2900
L	570	670	770	870	970	1070	1170	1270	1370	1470	1570	1670	1770	1870	1970	2070	2170	2270	2370	2470	2570	2670	2770	2870	2970	3070	3170	3270	3370
KG	13.4	14.1	14.8	15.4	16.1	16.8	17.5	18.1	18.8	19.5	20.1	20.8	21.5	22.2	22.8	23.5	24.2	24.9	25.5	26.2	26.9	27.6	28.2	28.9	29.6	30.2	30.9	31.6	32.3
有效行程	3000	3100	3200	3300	3400	3500	3600	3700	3800	3900	4000	4100	4200	4300	4400	4500	4600	4700	4800	4900	5000	5100	5200	5300	5400	5500	5600	5700	5800
L	3470	3570	3670	3770	3870	3970	4070	4170	4270	4370	4470	4570	4670	4770	4870	4970	5070	5170	5270	5370	5470	5570	5670	5770	5870	5970	6070	6170	6270
KG	33.0	33.7	34.4	35.1	35.8	36.5	37.2	37.9	38.6	39.3	40.0	40.7	41.4	42.1	42.8	43.5	44.2	44.9	45.6	46.3	47.0	47.7	48.4	49.1	49.8	50.5	51.2	51.9	52.6

注: 以上不含電機重量。Note: Not including motor weight.

如有特殊行程請先與技術人員聯系。in case special stroke please contact technical services.

靜態力矩表 Static torque gauge

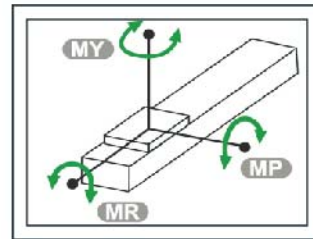

MY	210 (N.M)
MP	210 (N.M)
MR	75 (N.M)

馬達右折-R Motor Right Side

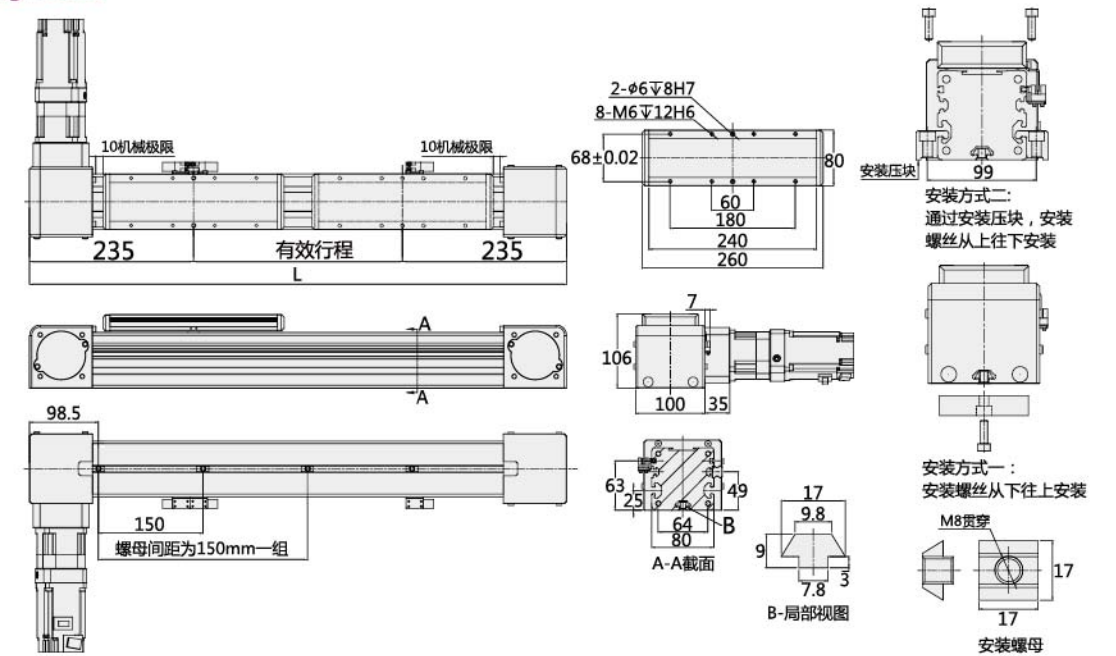

有效行程	100	200	300	400	500	600	700	800	900	1000	1100	1200	1300	1400	1500	1600	1700	1800	1900	2000	2100	2200	2300	2400	2500	2600	2700	2800	2900
L	570	670	770	870	970	1070	1170	1270	1370	1470	1570	1670	1770	1870	1970	2070	2170	2270	2370	2470	2570	2670	2770	2870	2970	3070	3170	3270	3370
KG	13.4	14.1	14.8	15.4	16.1	16.8	17.5	18.1	18.8	19.5	20.1	20.8	21.5	22.2	22.8	23.5	24.2	24.9	25.5	26.2	26.9	27.6	28.2	28.9	29.6	30.2	30.9	31.6	32.3
有效行程	3000	3100	3200	3300	3400	3500	3600	3700	3800	3900	4000	4100	4200	4300	4400	4500	4600	4700	4800	4900	5000	5100	5200	5300	5400	5500	5600	5700	5800
L	3470	3570	3670	3770	3870	3970	4070	4170	4270	4370	4470	4570	4670	4770	4870	4970	5070	5170	5270	5370	5470	5570	5670	5770	5870	5970	6070	6170	6270
KG	33.0	33.7	34.4	35.1	35.8	36.5	37.2	37.9	38.6	39.3	40.0	40.7	41.4	42.1	42.8	43.5	44.2	44.9	45.6	46.3	47.0	47.7	48.4	49.1	49.8	50.5	51.2	51.9	52.6

注: 以上不含電機重量。Note: Not including motor weight.

如有特殊行程請先與技術人員聯系。in case special stroke please contact technical services.

歐規同步帶滑臺-LB8H

EUCLIDEAN SYNCHRONIZATION BELT SLIDER



馬達安裝方式 Motor direction

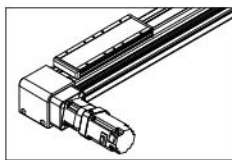

馬達左折-L
Motor Left Side

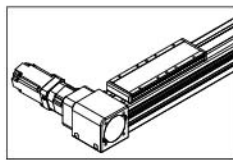

馬達右折-R
Motor Right Side

型號表示方式 Guide for Model Selection

LB8H-L176-S100-L-ZP40B-T5 - -N5 -001

本體型號 Base Style	*導程 Lead	行程mm Stroke(mm)	馬達方式 Motor way	馬達品牌 Motor Type	馬達功率 Motor power	感應開關數量 Sensor quantity	感應器類型 Sensor type	行星減速機 減速比 Planetary reducer Deceleration ratio	備註 Non-standard, d.c.
	L176 176mm <small>*導程：电机旋转一圈，滑台移动的直线距离。</small>	100-5700	L 左折 R 右折 Z 客户自配电机 無 我司配电机	P 松下 M 三菱 T 台达 Y 安川 57 57步進电机 其他品牌电机	40 400W 75 750W	D3 3PCS D2 2PCS D1 1PCS E 無關電開關	无 NPN P PNP	N5 5:1 N10 10:1 N15 15:1	
					剎車 Brakes				
					无 無剎車 B 帶剎車				

基本型號 Specification

馬達轉速(w) Motor Speed(rpm/mim)	400W		750W	
	5:1	10:1	5:1	10:1
行星減速機 (減速比) Gear reducer	5:1	10:1	5:1	10:1
*導程(mm) Lead(mm)	176/5	176/10	176/5	176/10
最高速度(mm/s) Maximum Payload(mm/s)	1760	880	1760	880
最大負載 (水平使用) Rated load	30	60	58	100
最大負載 (垂直使用) Rated load	10	22	20	40
額定推力 (N) Rated thrust(N)	208	416	385	770
行程範圍 Range of travel(mm)	100-5700MM/50行程遞增			
重複位置精度(mm) Repeatability(mm)	±0.05			
皮帶寬度(mm) Synchro band width(mm)	30(S8M)			
導軌規格(mm) Guide specification	W20XH15.5			
感應器 sensor	EE-SX674(NPN)			

*導程:電機旋轉一圈，滑臺移動的直線距離。

* Guide: the rotation of the motor and the straight distance of the sliding table.

*馬達加減速度時間為0.4S.
motor speed is 0.4S.

*如有特殊行程請先與技術人員聯系。

in case special stroke please contact technical services.

安裝示意圖 Installation Instratons&Dimentions

安裝方式一：

安裝螺絲從下往上安裝

method 1

fix the screw from bottom to up direction

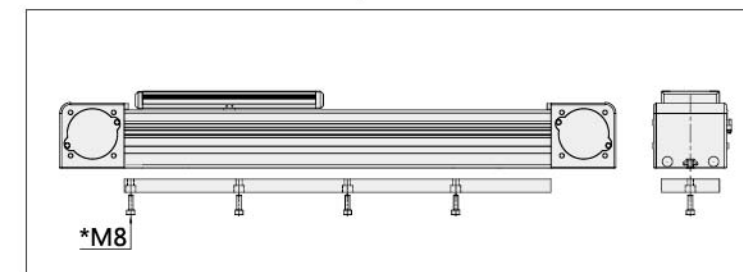

安裝方式二：

通過安裝壓塊，安裝螺絲從上往下安裝。

method 2

Install screw from top to bottom by installing press block

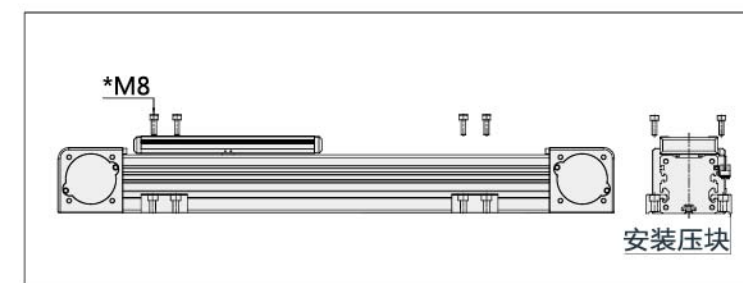

傳感器接線圖 Sensor Wiring diagram

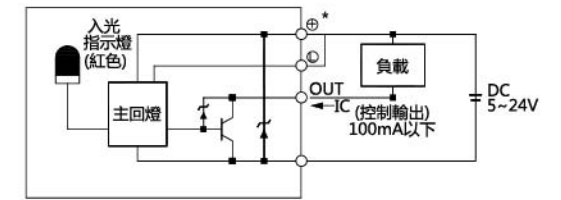

靜態力矩表 Static torque gauge

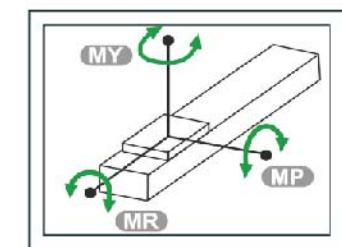

MY	333 (N.M)
MP	333 (N.M)
MR	118 (N.M)

馬達左折-L
Motor Left Side

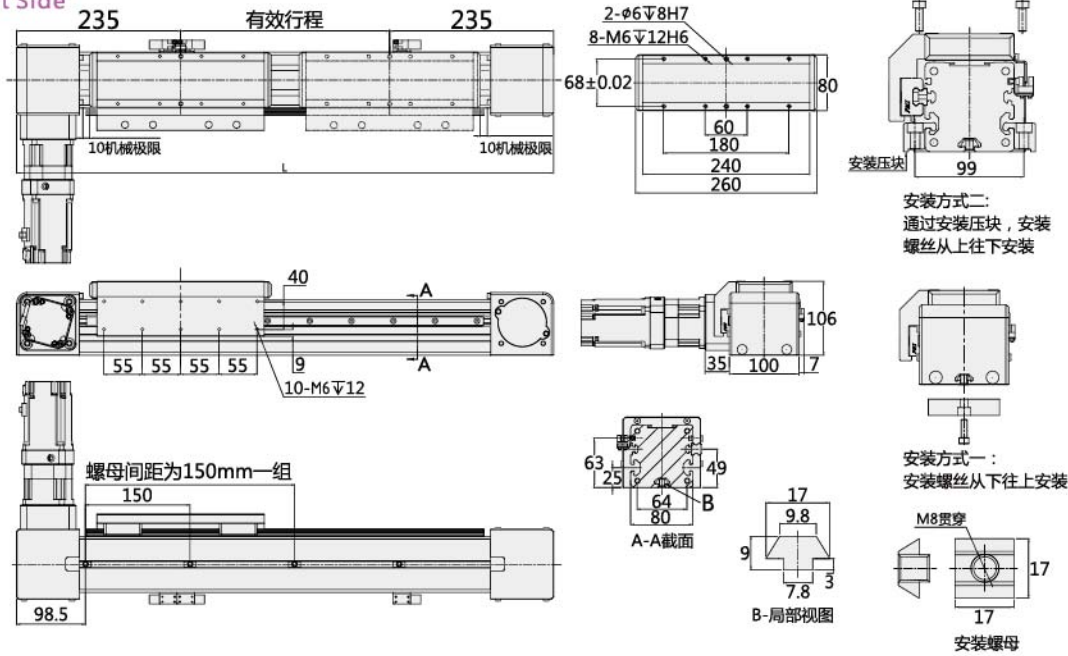

有效行程	100	200	300	400	500	600	700	800	900	1000	1100	1200	1300	1400	1500	1600	1700	1800	1900	2000	2100	2200	2300	2400	2500	2600	2700	2800	2900
L	570	670	770	870	970	1070	1170	1270	1370	1470	1570	1670	1770	1870	1970	2070	2170	2270	2370	2470	2570	2670	2770	2870	2970	3070	3170	3270	3370
KG	15.2	16.0	16.7	17.5	18.3	19.0	19.8	20.6	21.4	22.2	23.0	23.8	24.6	25.4	26.2	27.0	27.8	28.6	29.4	30.2	31.0	31.8	32.6	33.4	34.2	35.0	35.8	36.6	37.4
有效行程	3000	3100	3200	3300	3400	3500	3600	3700	3800	3900	4000	4100	4200	4300	4400	4500	4600	4700	4800	4900	5000	5100	5200	5300	5400	5500	5600	5700	5800
L	3470	3570	3670	3770	3870	3970	4070	4170	4270	4370	4470	4570	4670	4770	4870	4970	5070	5170	5270	5370	5470	5570	5670	5770	5870	5970	6070	6170	6270
KG	38.2	39.0	39.7	40.5	41.3	42.1	42.9	43.7	44.5	45.3	46.1	46.9	47.7	48.5	49.3	50.1	50.9	51.7	52.5	53.3	54.1	54.9	55.7	56.5	57.3	58.1	58.9	59.7	60.5

注：以上不含電機重量。Note: Not including motor weight.
如有特殊行程請先與技術人員聯繫。in case special stroke please contact technical services.

馬達右折-R
Motor Right Side

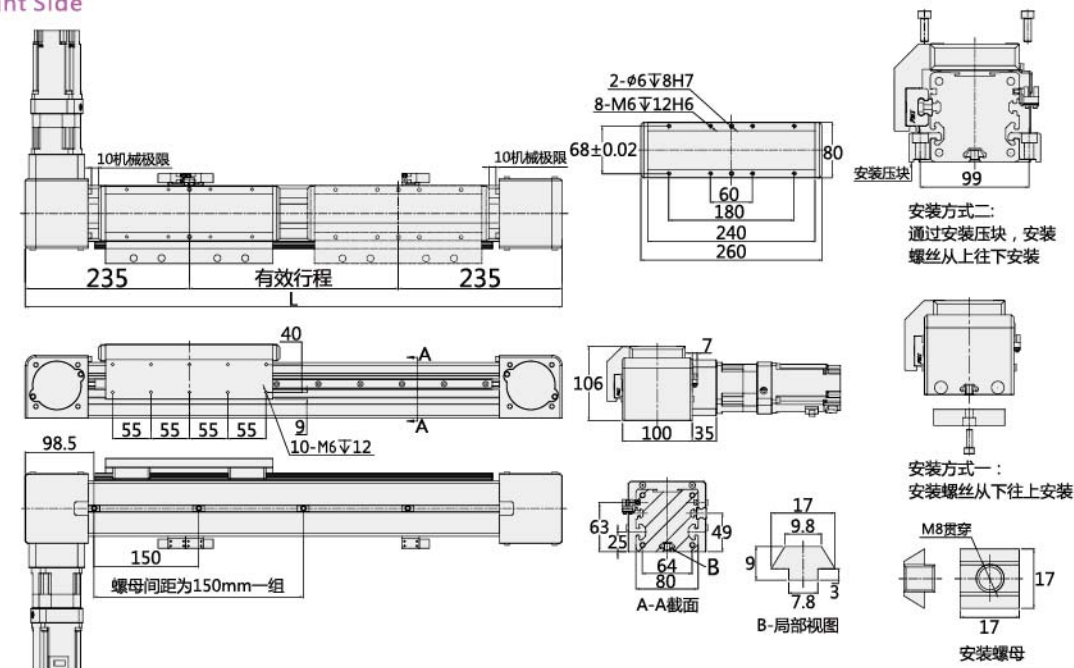

有效行程	100	200	300	400	500	600	700	800	900	1000	1100	1200	1300	1400	1500	1600	1700	1800	1900	2000	2100	2200	2300	2400	2500	2600	2700	2800	2900
L	570	670	770	870	970	1070	1170	1270	1370	1470	1570	1670	1770	1870	1970	2070	2170	2270	2370	2470	2570	2670	2770	2870	2970	3070	3170	3270	3370
KG	15.2	16.0	16.7	17.5	18.3	19.0	19.8	20.6	21.4	22.2	23.0	23.8	24.6	25.4	26.2	27.0	27.8	28.6	29.4	30.2	31.0	31.8	32.6	33.4	34.2	35.0	35.8	36.6	37.4
有效行程	3000	3100	3200	3300	3400	3500	3600	3700	3800	3900	4000	4100	4200	4300	4400	4500	4600	4700	4800	4900	5000	5100	5200	5300	5400	5500	5600	5700	5800
L	3470	3570	3670	3770	3870	3970	4070	4170	4270	4370	4470	4570	4670	4770	4870	4970	5070	5170	5270	5370	5470	5570	5670	5770	5870	5970	6070	6170	6270
KG	38.2	39.0	39.7	40.5	41.3	42.1	42.9	43.7	44.5	45.3	46.1	46.9	47.7	48.5	49.3	50.1	50.9	51.7	52.5	53.3	54.1	54.9	55.7	56.5	57.3	58.1	58.9	59.7	60.5

注：以上不含電機重量。Note: Not including motor weight.
如有特殊行程請先與技術人員聯繫。in case special stroke please contact technical services.

SEMI-CLOSED SYNCHRONIZED BELT SLIDER

半封閉同步帶滑臺-LB10



馬達安裝方式 Motor direction

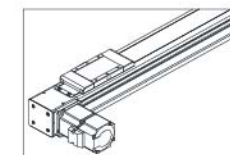

馬達左折-L
Motor Left Side

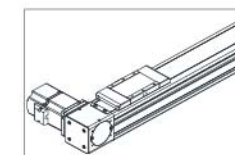

馬達右折-R
Motor Right Side

型號表示方式 Guide for Model Selection

LB10-L90-S100- L- ZP40B - T3 _ -001

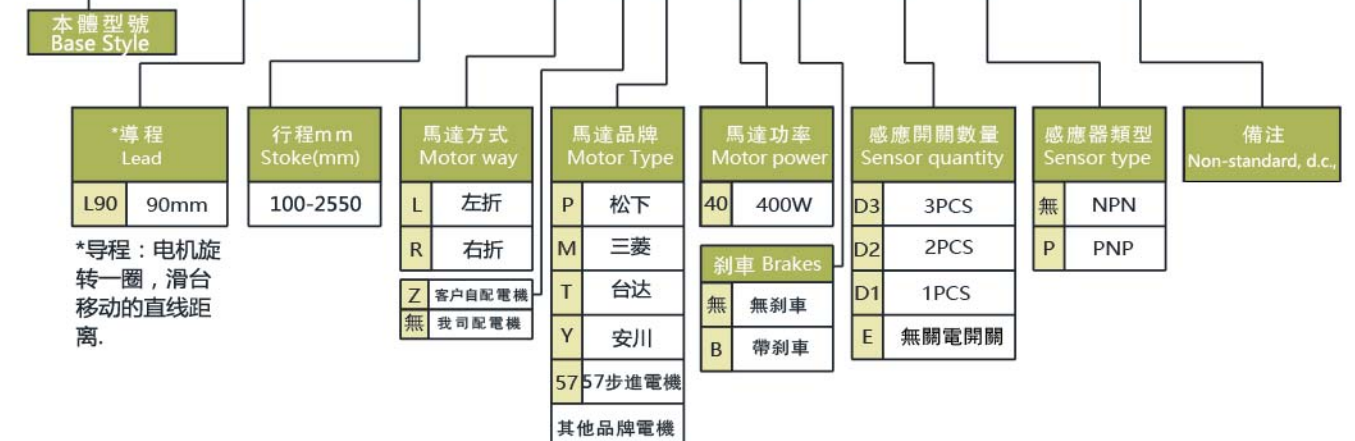

基本型號 Specification

馬達轉速(w) Motor Speed(rpm/mm)	500	1000	1500	2000	2500	3000
最高速度(mm/s) Maximum Payload(mm/s)	750	1500	2250	3000	3750	4500
最大負載 (水平使用) Rated load	15	8	5	3	2	1
重複位置精度(mm) Repeatability(mm)	±0.04					
*導程(mm) Lead(mm)	90					
額定推力 (N) Rated thrust(N)	81					
行程範圍 Range of travel(mm)	100-2550MM/50行程遞增					
馬達功率 Motor Output(w)	400					
皮帶寬度(mm) Synchro band width(mm)	20					
導軌規格(mm) Guide specification	W15XH12-2支					
連軸器 coupling	12X14					
感應器 sensor	EE-SX674(NPN)					

*導程:電機旋轉一圈,滑臺移動的直線距離。

* Guide: the rotation of the motor and the straight distance of the sliding table.

*馬達加減速度時間為0.4S.

motor speed is 0.4S.

*如有特殊行程請先與技術人員聯系。

in case special stroke please contact technical services.

安裝示意圖 Installation Instrations&Dimentions

安裝方式一:

安裝螺絲從上往下安裝

*注意鎖緊螺絲轉入滑臺的長度不得超過11mm, 否則會與內部干涉。

Note that the length of the locking screw installed in the slide shall not exceed 10mm, otherwise it will interfere with the internal.

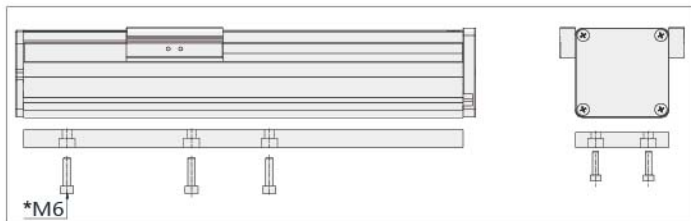

安裝方式二:

打開滑臺上蓋, 安裝螺絲從上往下安裝
method 2

Open the top cover of the slide and install the screw from top to bottom

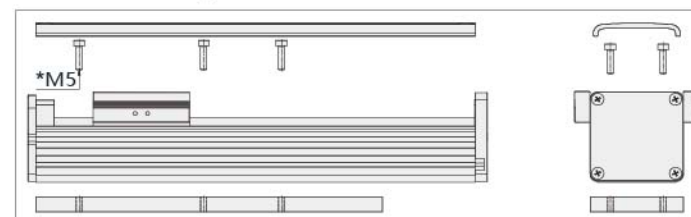

傳感器接綫圖 Sensor Wiring diagram

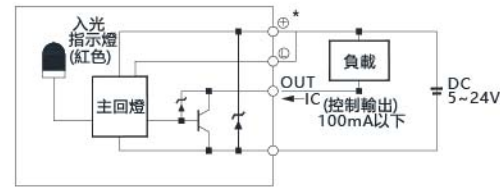

負載與速度 Speed and stroek

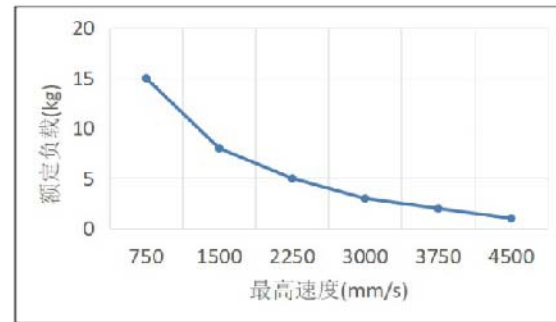

靜態力矩表 Static torque gauge

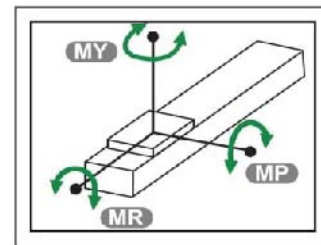

MY	160 (N.M)
MP	160 (N.M)
MR	140 (N.M)

馬達左折-L Motor Left Side

安裝方式一:

安裝螺絲從下往上安裝
*注意鎖緊螺絲裝入滑臺的長度不得超過11mm, 否則會與內部干涉。

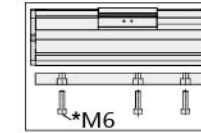

安裝方式二:

打開滑臺上蓋, 安裝螺絲從上往下安裝

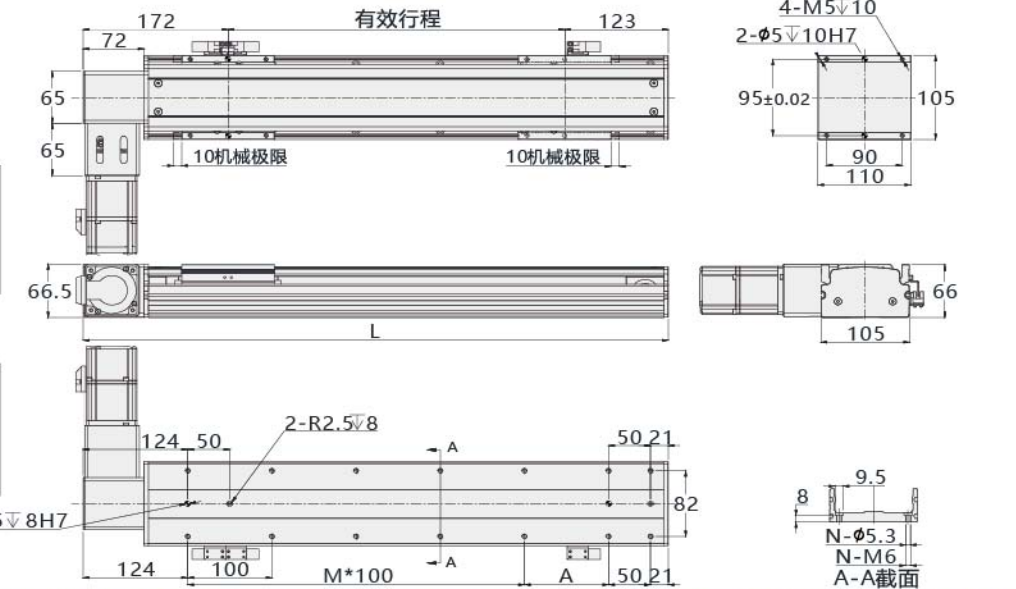
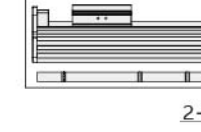

有效行程	50	100	150	200	250	300	350	400	450	500	550	600	650	700	750	800	850	900	950	1000	1050	1100	1150	1200	1250	1300
L	345	395	445	495	545	595	645	695	745	795	845	895	945	995	1045	1095	1145	1195	1245	1295	1345	1395	1445	1495	1545	1595
A	50	100	50	100	50	100	50	100	50	100	50	100	50	100	50	100	50	100	50	100	50	100	50	100	50	100
M	1	1	2	2	3	3	4	4	5	5	6	6	7	7	8	8	9	9	10	10	11	11	12	12	13	13
N	8	8	10	10	12	12	14	14	16	16	18	18	20	20	22	22	24	24	26	26	28	28	30	30	32	32
KG	4.8	5.1	5.4	5.7	6	6.3	6.6	6.9	7.2	7.5	7.8	8.1	8.4	8.7	9	9.3	9.6	9.9	10.2	10.5	10.8	11.1	11.4	11.7	12	12.3
有效行程	1350	1400	1450	1500	1550	1600	1650	1700	1750	1800	1850	1900	1950	2000	2050	2100	2150	2200	2250	2300	2350	2400	2450	2500	2550	2600
L	1645	1695	1745	1795	1845	1895	1945	1995	2045	2095	2145	2195	2245	2295	2345	2395	2445	2495	2545	2595	2645	2695	2745	2795	2845	2895
A	50	100	50	100	50	100	50	100	50	100	50	100	50	100	50	100	50	100	50	100	50	100	50	100	50	100
M	14	14	15	15	16	16	17	17	18	18	19	19	20	20	21	21	22	22	23	23	24	24	25	25	26	26
N	34	34	36	36	38	38	40	40	42	42	44	44	46	46	48	48	50	50	52	52	54	54	56	56	58	58
KG	12.6	13.1	13.4	13.9	14.2	14.5	15	15.3	15.7	16	16.3	16.7	17	17.4	17.7	18	18.3	18.6	19	19.4	19.7	20.1	20.4	20.8	21.2	21.6

注: 以上不含電機重量。 Note: Not including motor weight..

馬達右折-R Motor Right Side

安裝方式一:

安裝螺絲從下往上安裝
*注意鎖緊螺絲裝入滑臺的長度不得超過11mm, 否則會與內部干涉。

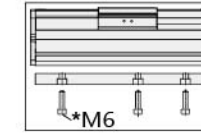

安裝方式二:

打開滑臺上蓋, 安裝螺絲從上往下安裝

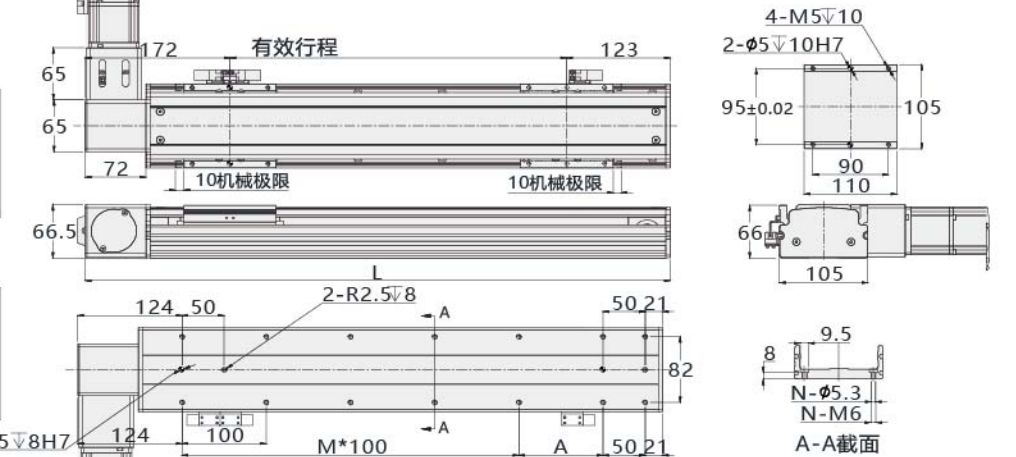
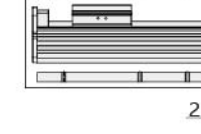

有效行程	50	100	150	200	250	300	350	400	450	500	550	600	650	700	750	800	850	900	950	1000	1050	1100	1150	1200	1250	1300
L	345	395	445	495	545	595	645	695	745	795	845	895	945	995	1045	1095	1145	1195	1245	1295	1345	1395	1445	1495	1545	1595
A	50	100	50	100	50	100	50	100	50	100	50	100	50	100	50	100	50	100	50	100	50	100	50	100	50	100
M	1	1	2	2	3	3	4	4	5	5	6	6	7	7	8	8	9	9	10	10	11	11	12	12	13	13
N	8	8	10	10	12	12	14	14	16	16	18	18	20	20	22	22	24	24	26	26	28	28	30	30	32	32
KG	4.8	5.1	5.4	5.7	6	6.3	6.6	6.9	7.2	7.5	7.8	8.1	8.4	8.7	9	9.3	9.6	9.9	10.2	10.5	10.8	11.1	11.4	11.7	12	12.3
有效行程	1350	1400	1450	1500	1550	1600	1650	1700	1750	1800	1850	1900	1950	2000	2050	2100	2150	2200	2250	2300	2350	2400	2450	2500	2550	2600
L	1645	1695	1745	1795	1845	1895	1945	1995	2045	2095	2145	2195	2245	2295	2345	2395	2445	2495	2545	2595	2645	2695	2745	2795	2845	2895
A	50	100	50	100	50	100	50	100	50	100	50	100	50	100	50	100	50	100	50	100	50	100	50	100	50	100
M	14	14	15	15	16	16	17	17	18	18	19	19	20	20	21	21	22	22	23	23	24	24	25	25	26	26
N	34	34	36	36	38	38	40	40	42	42	44	44	46	46	48	48	50	50	52	52	54	54	56	56	58	58
KG	12.6	13.1	13.4	13.9	14.2	14.5	15	15.3	15.7	16	16.3	16.7	17	17.4	17.7	18	18.3	18.6	19	19.4	19.7	20.1	20.4	20.8	21.2	21.6

注: 以上不含電機重量。 Note: Not including motor weight..

半封閉同步帶滑臺-LB10H

SEMI-CLOSED SYNCHRONIZED BELT SLIDER



馬達安裝方式 Motor direction

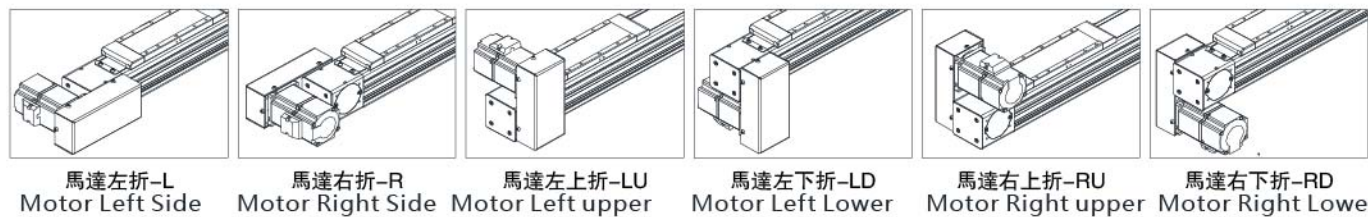

型號表示方式 Guide for Model Selection

LB10H - L45 - S100 - L - ZP20B - T3 _ -001

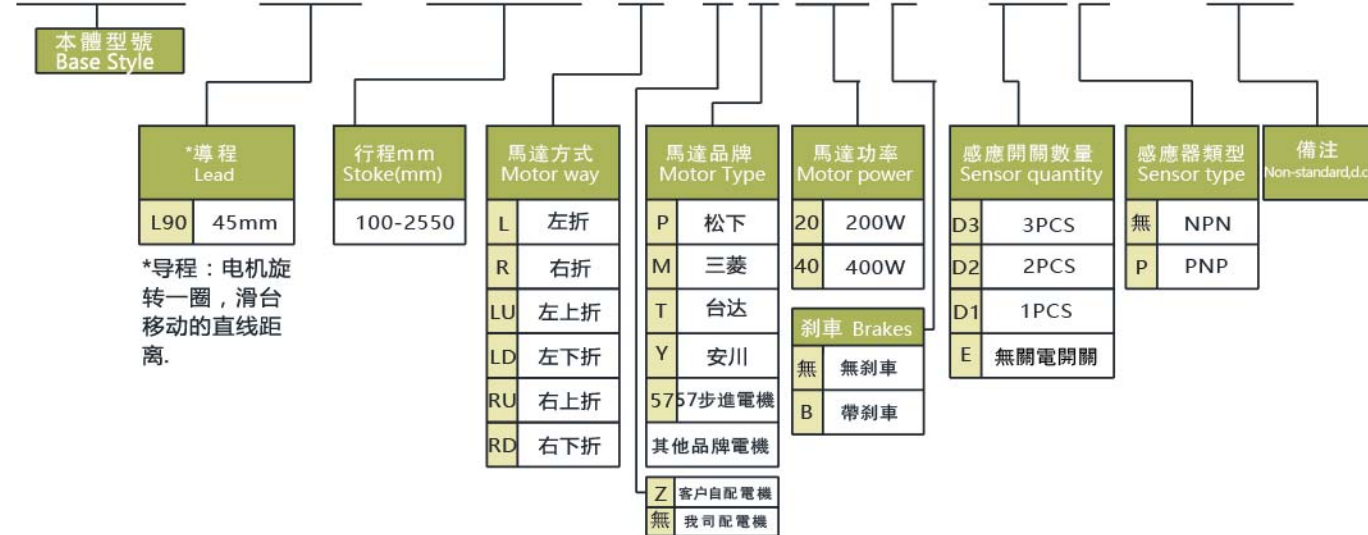

基本型號 Specification

馬達轉速(w) Motor Speed(rpm/mim)	500	1000	1500	2000	2500	3000
最高速度(mm/s) Maximum Payload(mm/s)	375	750	1125	1500	1875	2250
最大負載 (水平使用) Rated load	20	15	11	7	5	4
重複位置精度(mm) Repeatability(mm)	±0.04					
*導程(mm) Lead(mm)	45					
額定推力 (N) Rated thrust(N)	80					
行程範圍 Range of travel(mm)	100-2550MM/50行程遞增					
馬達功率 Motor Output(w)	200(400)					
皮帶寬度(mm) Synchro band width(mm)	20					
導軌規格(mm) Guide specification	W15XH12-2支					
感應器 sensor	EE-SX674(NPN)					

*導程:電機旋轉一圈，滑臺移動的直線距離。

* Guide: the rotation of the motor and the straight distance of the sliding table.

*馬達加減速度時間為0.4S.
motor speed is 0.4S.

*如有特殊行程請先與技術人員聯系。

in case special stroke please contact technical services.

安裝示意圖 Installation Instrations&Dimentions

安裝方式一:

安裝螺絲從上往下安裝

*注意鎖緊螺絲轉入滑臺的長度不得超過11mm，否則會與內部干涉。
Note that the length of the locking screw installed in the slide shall not exceed 10mm, otherwise it will interfere with the internal.

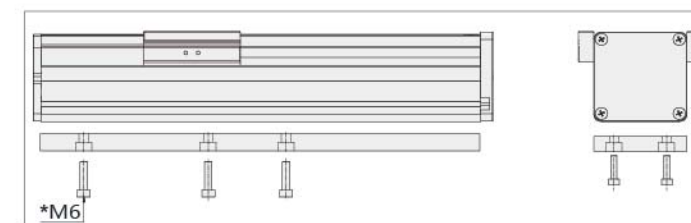

安裝方式二:

打開滑臺上蓋，安裝螺絲從上往下安裝

method 2
Open the top cover of the slide and install the screw from top to bottom

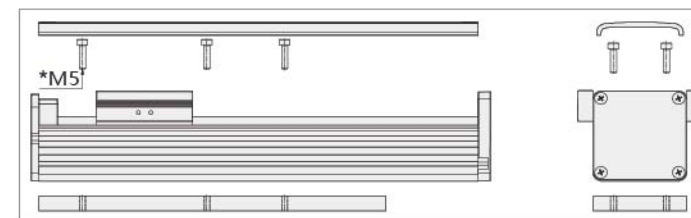

傳感器接線圖 Sensor Wiring diagram

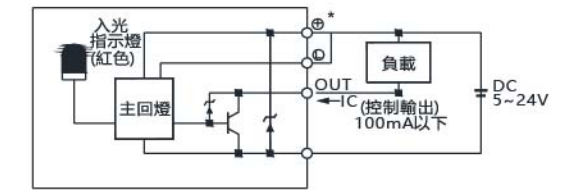

負載與速度 Speed and strok

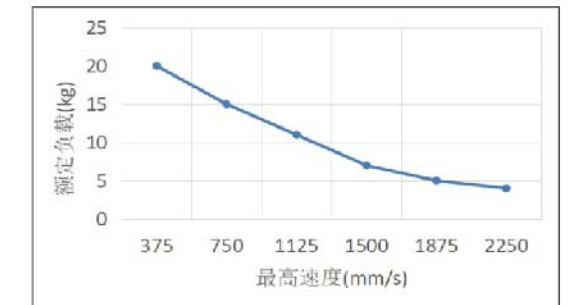

靜態力矩表 Static torque gauge

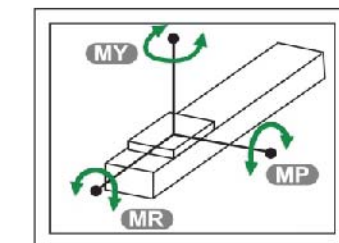

MY	160 (N.M)
MP	160 (N.M)
MR	140 (N.M)

馬達左折-L Motor Left Side

安裝方式一：
安裝螺絲從下往上安裝
*注意鎖緊螺絲裝入滑台
的長度不得超過11mm，
否則會與內部干涉。

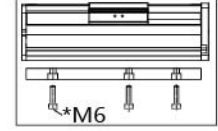

安裝方式二：
打開滑台上蓋，
安裝螺絲從上往下安裝。

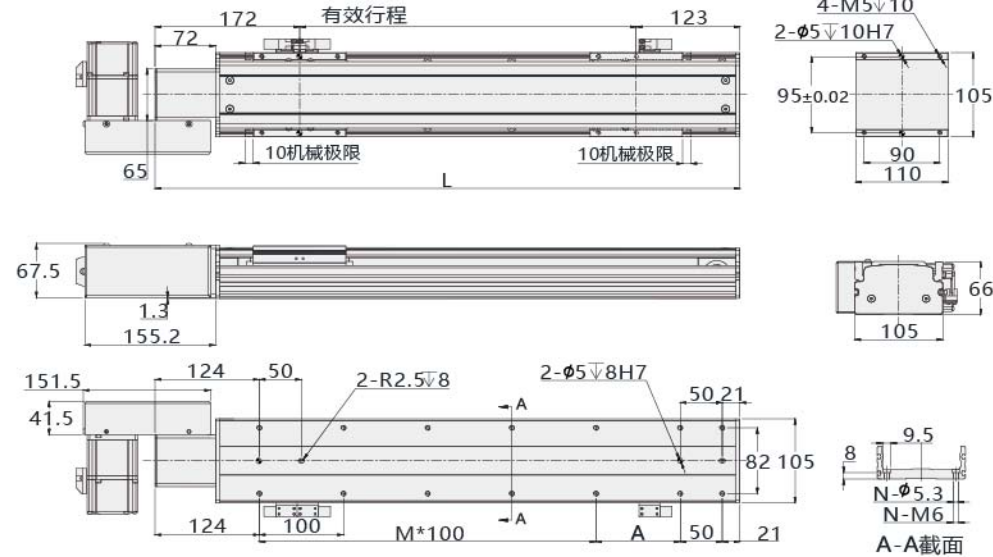

有效行程	50	100	150	200	250	300	350	400	450	500	550	600	650	700	750	800	850	900	950	1000	1050	1100	1150	1200	1250	1300
L	345	395	445	495	545	595	645	695	745	795	845	895	945	995	1045	1095	1145	1195	1245	1295	1345	1395	1445	1495	1545	1595
A	50	100	50	100	50	100	50	100	50	100	50	100	50	100	50	100	50	100	50	100	50	100	50	100	50	100
M	1	1	2	2	3	3	4	4	5	5	6	6	7	7	8	8	9	9	10	10	11	11	12	12	13	13
N	8	8	10	10	12	12	14	14	16	16	18	18	20	20	22	22	24	24	26	26	28	28	30	30	32	32
KG	5.1	5.4	5.7	6	6.3	6.6	6.9	7.2	7.5	7.8	8.1	8.4	8.7	9	9.3	9.6	9.9	10.2	10.5	10.8	11.1	11.4	11.7	12	12.3	12.6

有效行程	1350	1400	1450	1500	1550	1600	1650	1700	1750	1800	1850	1900	1950	2000	2050	2100	2150	2200	2250	2300	2350	2400	2450	2500	2550	2600
L	1645	1695	1745	1795	1845	1895	1945	1995	2045	2095	2145	2195	2245	2295	2345	2395	2445	2495	2545	2595	2645	2695	2745	2795	2845	2895
A	50	100	50	100	50	100	50	100	50	100	50	100	50	100	50	100	50	100	50	100	50	100	50	100	50	100
M	14	14	15	15	16	16	17	17	18	18	19	19	20	20	21	21	22	22	23	23	24	24	25	25	26	26
N	34	34	36	36	38	38	40	40	42	42	44	44	46	46	48	48	50	50	52	52	54	54	56	56	58	58
KG	13.1	13.4	13.9	14.2	14.5	15	15.3	15.7	16	16.3	16.7	17	17.4	17.7	18	18.3	18.6	19	19.4	19.7	20.1	20.4	20.8	21.2	21.6	22

注：以上不含電機重量。Note: Not including motor weight..

馬達左上折-LU Motor Left upper

安裝方式一：
安裝螺絲從下往上安裝
*注意鎖緊螺絲裝入滑台
的長度不得超過11mm，
否則會與內部干涉。

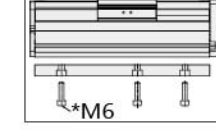

安裝方式二：
打開滑台上蓋，
安裝螺絲從上往下安裝。

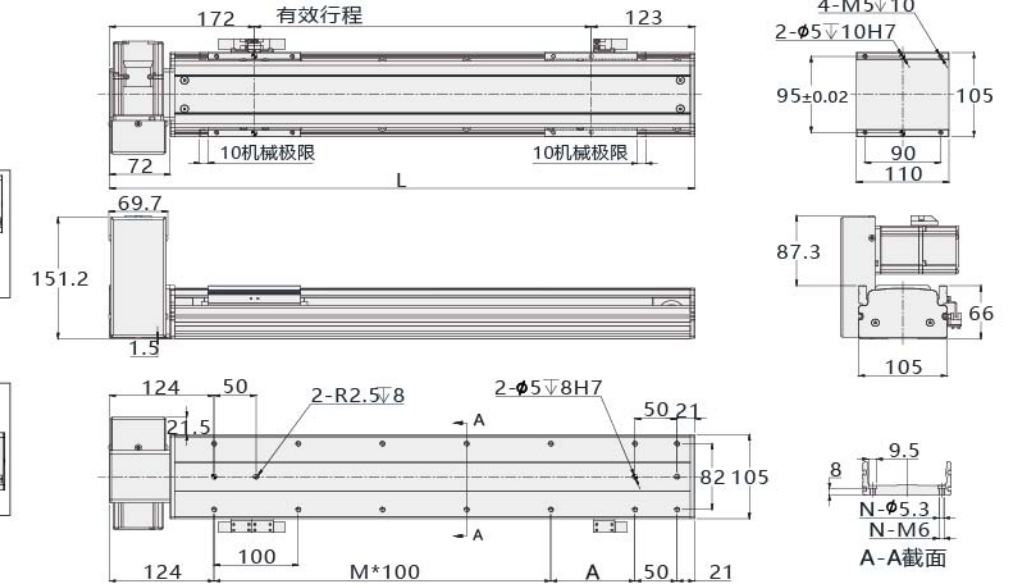
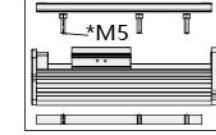

有效行程	50	100	150	200	250	300	350	400	450	500	550	600	650	700	750	800	850	900	950	1000	1050	1100	1150	1200	1250	1300
L	345	395	445	495	545	595	645	695	745	795	845	895	945	995	1045	1095	1145	1195	1245	1295	1345	1395	1445	1495	1545	1595
A	50	100	50	100	50	100	50	100	50	100	50	100	50	100	50	100	50	100	50	100	50	100	50	100	50	100
M	1	1	2	2	3	3	4	4	5	5	6	6	7	7	8	8	9	9	10	10	11	11	12	12	13	13
N	8	8	10	10	12	12	14	14	16	16	18	18	20	20	22	22	24	24	26	26	28	28	30	30	32	32
KG	5.1	5.4	5.7	6	6.3	6.6	6.9	7.2	7.5	7.8	8.1	8.4	8.7	9	9.3	9.6	9.9	10.2	10.5	10.8	11.1	11.4	11.7	12	12.3	12.6

有效行程	1350	1400	1450	1500	1550	1600	1650	1700	1750	1800	1850	1900	1950	2000	2050	2100	2150	2200	2250	2300	2350	2400	2450	2500	2550	2600
L	1645	1695	1745	1795	1845	1895	1945	1995	2045	2095	2145	2195	2245	2295	2345	2395	2445	2495	2545	2595	2645	2695	2745	2795	2845	2895
A	50	100	50	100	50	100	50	100	50	100	50	100	50	100	50	100	50	100	50	100	50	100	50	100	50	100
M	14	14	15	15	16	16	17	17	18	18	19	19	20	20	21	21	22	22	23	23	24	24	25	25	26	26
N	34	34	36	36	38	38	40	40	42	42	44	44	46	46	48	48	50	50	52	52	54	54	56	56	58	58
KG	13.1	13.4	13.9	14.2	14.5	15	15.3	15.7	16	16.3	16.7	17	17.4	17.7	18	18.3	18.6	19	19.4	19.7	20.1	20.4	20.8	21.2	21.6	22

注：以上不含電機重量。Note: Not including motor weight..

馬達右折-R Motor Right Side

安裝方式一：
安裝螺絲從下往上安裝
*注意鎖緊螺絲裝入滑台
的長度不得超過11mm，
否則會與內部干涉。

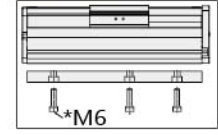

安裝方式二：
打開滑台上蓋，
安裝螺絲從上往下安裝。

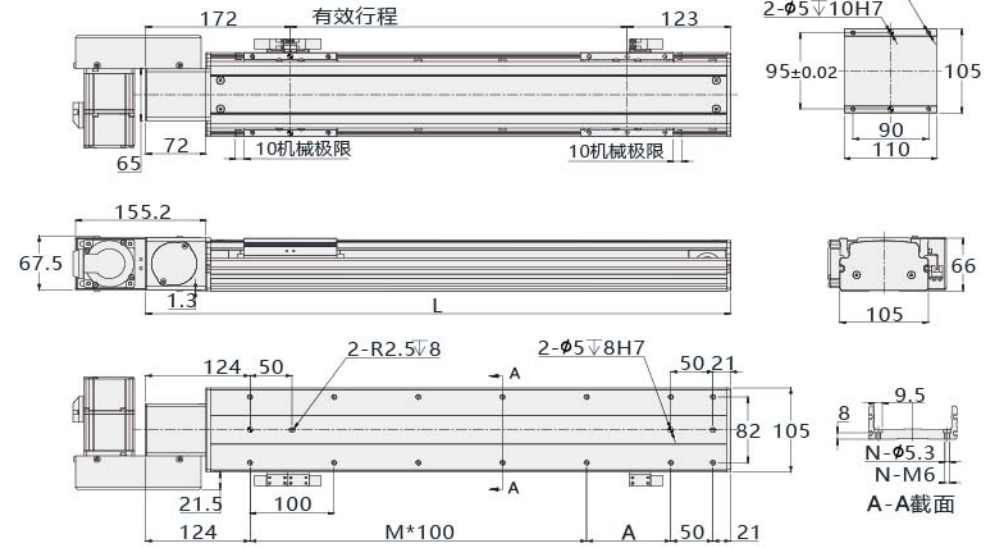

有效行程	50	100	150	200	250	300	350	400	450	500	550	600	650	700	750	800	850	900	950	1000	1050	1100	1150	1200	1250	1300
L	345	395	445	495	545	595	645	695	745	795	845	895	945	995	1045	1095	1145	1195	1245	1295	1345	1395	1445	1495	1545	1595
A	50	100	50	100	50	100	50	100	50	100	50	100	50	100	50	100	50	100	50	100	50	100	50	100	50	100
M	1	1	2	2	3	3	4	4	5	5	6	6	7	7	8	8	9	9	10	10	11	11	12	12	13	13
N	8	8	10	10	12	12	14	14	16	16	18	18	20	20	22	22	24	24	26	26	28	28	30	30	32	32
KG	5.1	5.4	5.7	6	6.3	6.6	6.9	7.2	7.5	7.8	8.1	8.4	8.7	9	9.3	9.6	9.9	10.2	10.5	10.8	11.1	11.4	11.7	12	12.3	12.6

有效行程	1350	1400	1450	1500	1550	1600	1650	1700	1750	1800	1850	1900	1950	2000	2050	2100	2150	2200	2250	2300	2350	2400	2450	2500	2550	2600
L	1645	1695	1745	1795	1845	1895	1945	1995	2045	2095	2145	2195	2245	2295	2345	2395	2445	2495	2545	2595	2645	2695	2745	2795	2845	2895
A	50	100	50	100	50	100	50	100	50	100	50	100	50	100	50	100	50	100	50	100	50	100	50	100	50	100
M	14	14	15	15	16	16	17	17	18	18	19	19	20	20	21	21	22	22	23	23	24	24	25	25	26	26
N	34	34	36	36	38	38	40	40	42	42	44	44	46	46	48	48	50	50	52	52	54	54	56	56	58	58
KG	13.1	13.4	13.9	14.2	14.5	15	15.3	15.7	16	16.3	16.7	17	17.4	17.7	18	18.3	18.6	19	19.4	19.7	20.1	20.4	20.8	21.2	21.6	22

注：以上不含電機重量。Note: Not including motor weight..

馬達左下折-LD Motor Right Side

安裝方式一：
安裝螺絲從下往上安裝
*注意鎖緊螺絲裝入滑台
的長度不得超過11mm，
否則會與內部干涉。



安裝方式二：
打開滑台上蓋，
安裝螺絲從上往下安裝。

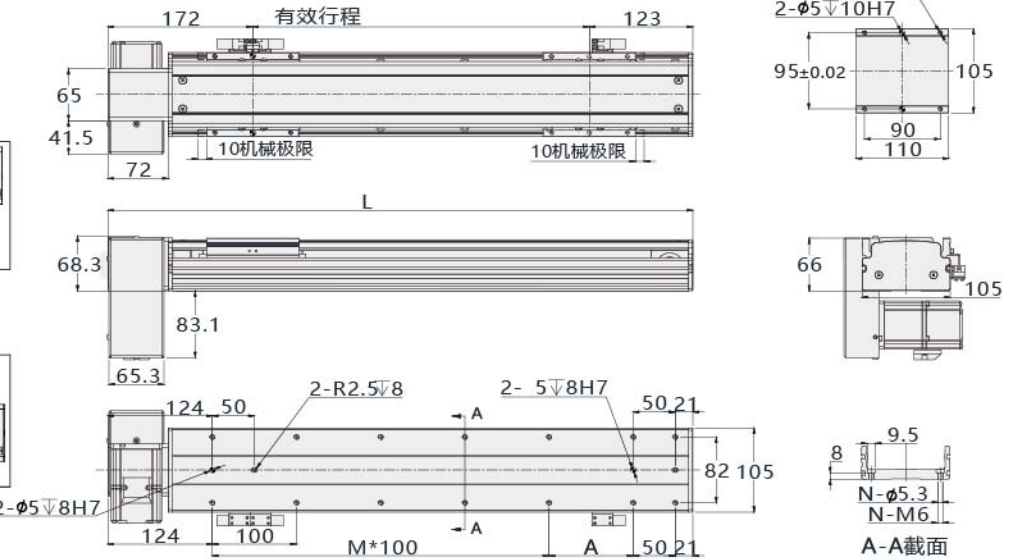
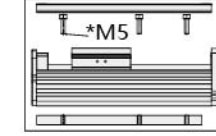

有效行程	50	100	150	200	250	300	350	400	450	500	550	600	650	700	750	800	850	900	950	1000	1050	1100	1150	1200	1250	1300
L	345	395	445	495	545	595	645	695	745	795	845	895	945	995	1045	1095	1145	1195	1245	1295	1345	1395	1445	1495	1545	1595
A	50	100	50	100	50	100	50	100	50	100	50	100	50	100	50	100	50	100	50	100	50	100	50	100	50	100
M	1	1	2	2	3	3	4	4	5	5	6	6	7	7	8	8	9	9	10	10	11	11	12	12	13	13
N	8	8	10	10	12	12	14	14	16	16	18	18	20	20	22	22	24	24	26	26	28	28	30	30	32	32
KG	5.1	5.4	5.7	6	6.3	6.6	6.9	7.2	7.5	7.8	8.1	8.4	8.7	9	9.3	9.6	9.9	10.2	10.5	10.8	11.1	11.4	11.7	12	12.3	12.6

有效行程	1350	1400	1450	1500	1550	1600	1650	1700	1750	1800	1850	1900	1950	2000	2050	2100	2150	2200	2250	2300	2350	2400	2450	2500	2550	2600
L	1645	1695	1745	1795	1845	1895	1945	1995	2045	2095	2145	2195	2245	2295	2345	2395	2445	2495	2545	2595	2645	2695	2745	2795	2845	2895
A	50	100	50	100	50	100	50	100	50	100	50	100	50	100	50	100	50	100	50	100	50	100	50	100	50	100
M	14	14	15	15	16	16	17	17	18	18	19	19	20													

馬達右上折-RU
Motor Left Side

安裝方式一:
安裝螺絲從下往上安裝
*注意鎖緊螺絲裝入滑台的長度不得超過11mm, 否則會與內部干涉。

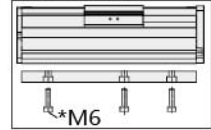

安裝方式二:
打開滑台上蓋,
安裝螺絲從上往下安裝。

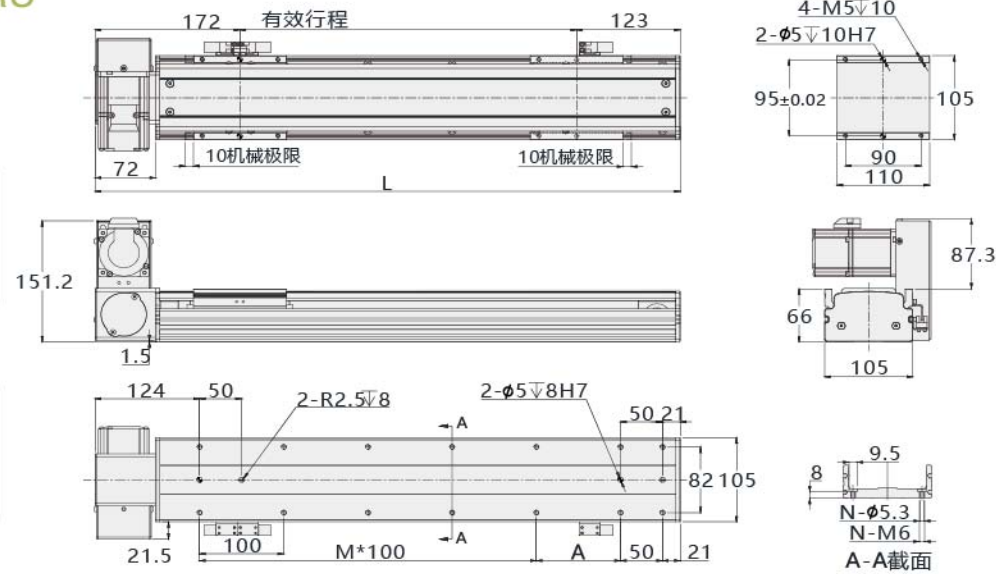

有效行程	50	100	150	200	250	300	350	400	450	500	550	600	650	700	750	800	850	900	950	1000	1050	1100	1150	1200	1250	1300
L	345	395	445	495	545	595	645	695	745	795	845	895	945	995	1045	1095	1145	1195	1245	1295	1345	1395	1445	1495	1545	1595
A	50	100	50	100	50	100	50	100	50	100	50	100	50	100	50	100	50	100	50	100	50	100	50	100	50	100
M	1	1	2	2	3	3	4	4	5	5	6	6	7	7	8	8	9	9	10	10	11	11	12	12	13	13
N	8	8	10	10	12	12	14	14	16	16	18	18	20	20	22	22	24	24	26	26	28	28	30	30	32	32
KG	5.1	5.4	5.7	6	6.3	6.6	6.9	7.2	7.5	7.8	8.1	8.4	8.7	9	9.3	9.6	9.9	10.2	10.5	10.8	11.1	11.4	11.7	12	12.3	12.6
有效行程	1350	1400	1450	1500	1550	1600	1650	1700	1750	1800	1850	1900	1950	2000	2050	2100	2150	2200	2250	2300	2350	2400	2450	2500	2550	2600
L	1645	1695	1745	1795	1845	1895	1945	1995	2045	2095	2145	2195	2245	2295	2345	2395	2445	2495	2545	2595	2645	2695	2745	2795	2845	2895
A	50	100	50	100	50	100	50	100	50	100	50	100	50	100	50	100	50	100	50	100	50	100	50	100	50	100
M	14	14	15	15	16	16	17	17	18	18	19	19	20	20	21	21	22	22	23	23	24	24	25	25	26	26
N	34	34	36	36	38	38	40	40	42	42	44	44	46	46	48	48	50	50	52	52	54	54	56	56	58	58
KG	13.1	13.4	13.9	14.2	14.5	15	15.3	15.7	16	16.3	16.7	17	17.4	17.7	18	18.3	18.6	19	19.4	19.7	20.1	20.4	20.8	21.2	21.6	22

注: 以上不含電機重量。Note: Not including motor weight..

馬達右下折-RD
Motor Right Side

安裝方式一:
安裝螺絲從下往上安裝
*注意鎖緊螺絲裝入滑台的長度不得超過11mm, 否則會與內部干涉。

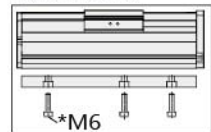

安裝方式二:
打開滑台上蓋,
安裝螺絲從上往下安裝。

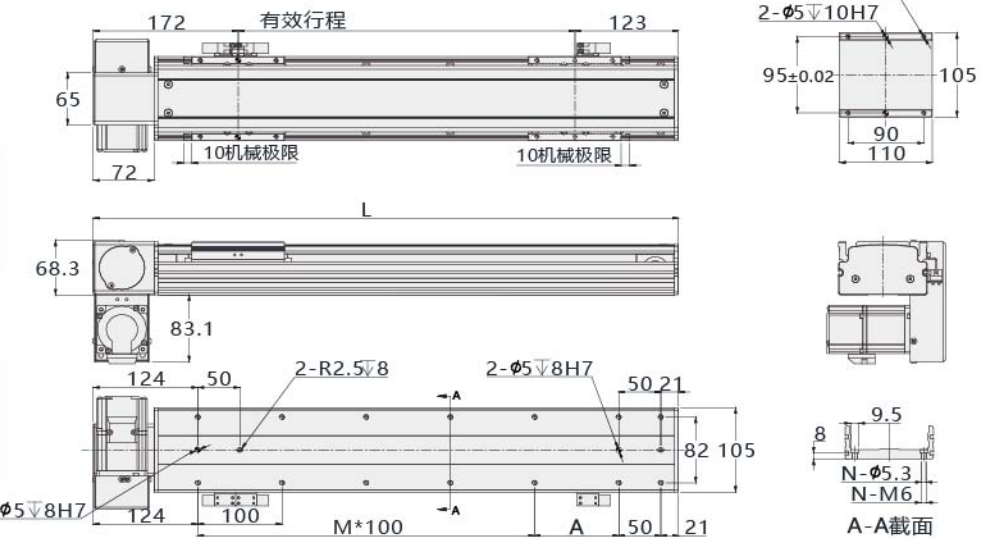
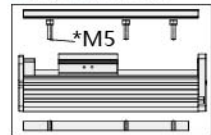

有效行程	50	100	150	200	250	300	350	400	450	500	550	600	650	700	750	800	850	900	950	1000	1050	1100	1150	1200	1250	1300
L	345	395	445	495	545	595	645	695	745	795	845	895	945	995	1045	1095	1145	1195	1245	1295	1345	1395	1445	1495	1545	1595
A	50	100	50	100	50	100	50	100	50	100	50	100	50	100	50	100	50	100	50	100	50	100	50	100	50	100
M	1	1	2	2	3	3	4	4	5	5	6	6	7	7	8	8	9	9	10	10	11	11	12	12	13	13
N	8	8	10	10	12	12	14	14	16	16	18	18	20	20	22	22	24	24	26	26	28	28	30	30	32	32
KG	5.1	5.4	5.7	6	6.3	6.6	6.9	7.2	7.5	7.8	8.1	8.4	8.7	9	9.3	9.6	9.9	10.2	10.5	10.8	11.1	11.4	11.7	12	12.3	12.6
有效行程	1350	1400	1450	1500	1550	1600	1650	1700	1750	1800	1850	1900	1950	2000	2050	2100	2150	2200	2250	2300	2350	2400	2450	2500	2550	2600
L	1645	1695	1745	1795	1845	1895	1945	1995	2045	2095	2145	2195	2245	2295	2345	2395	2445	2495	2545	2595	2645	2695	2745	2795	2845	2895
A	50	100	50	100	50	100	50	100	50	100	50	100	50	100	50	100	50	100	50	100	50	100	50	100	50	100
M	14	14	15	15	16	16	17	17	18	18	19	19	20	20	21	21	22	22	23	23	24	24	25	25	26	26
N	34	34	36	36	38	38	40	40	42	42	44	44	46	46	48	48	50	50	52	52	54	54	56	56	58	58
KG	13.1	13.4	13.9	14.2	14.5	15	15.3	15.7	16	16.3	16.7	17	17.4	17.7	18	18.3	18.6	19	19.4	19.7	20.1	20.4	20.8	21.2	21.6	22

注: 以上不含電機重量。Note: Not including motor weight..

馬達安裝方式 Motor direction

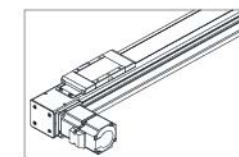

馬達左折-L
Motor Left Side

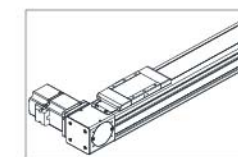

馬達右折-R
Motor Right Side

型號表示方式 Guide for Model Selection

LB13 -L90 -S100 - L- ZP40B-T3 _ -001

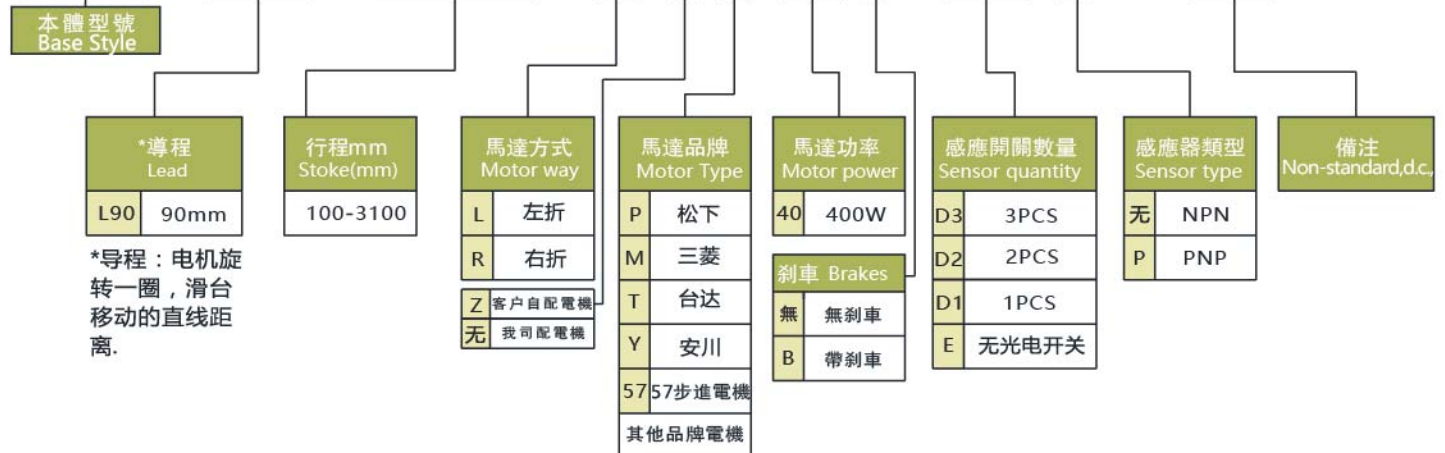

基本型號 Specification

馬達轉速(w) Motor Speed(rpm/min)	500	1000	1500	2000	2500	3000
最高速度(mm/s) Maximum Payload(mm/s)	750	1500	2250	3000	3750	4500
最大負載 (水平使用) Rated load	17	9	6	4	2	1
重複位置精度(mm) Repeatability(mm)	±0.04					
*導程(mm) Lead(mm)	90					
額定推力 (N) Rated thrust(N)	81					
行程範圍 Range of travel(mm)	100-3100MM/50行程遞增					
馬達功率 Motor Output(w)	400					
皮帶寬度(mm) Synchro band width(mm)	20					
導軌規格(mm) Guide specification	W15XH12-2支					
連軸器 coupling	12X14					
感應器 sensor	EE-SX674(NPN)					

*導程:電機旋轉一圈,滑臺移動的直線距離。

* Guide: the rotation of the motor and the straight distance of the sliding table.

*馬達加減速度時間為0.4S.
motor speed is 0.4S.

*如有特殊行程請先與技術人員聯系。

in case special stroke please contact technical services.

安裝示意圖 Installation Instrations&Dimentions

安裝方式一:

安裝螺絲從上往下安裝

*注意鎖緊螺絲轉入滑臺的長度不得超過11mm,否則會與內部干涉。

Note that the length of the locking screw installed in the slide shall not exceed 10mm, otherwise it will interfere with the internal.

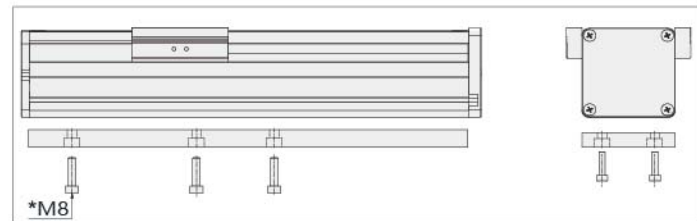

安裝方式二:

打開滑臺上蓋,安裝螺絲從上往下安裝
method 2

Open the top cover of the slide and install the screw from top to bottom

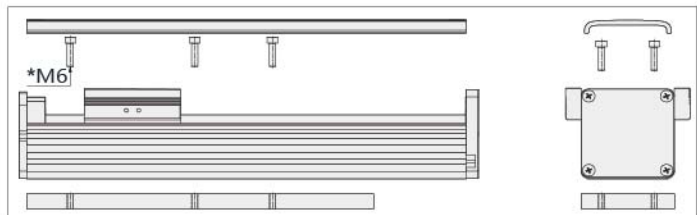

傳感器接綫圖 Sensor Wiring diagram

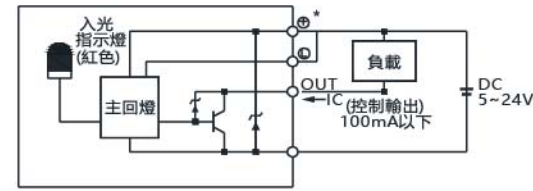

負載與速度 Speed and stroke

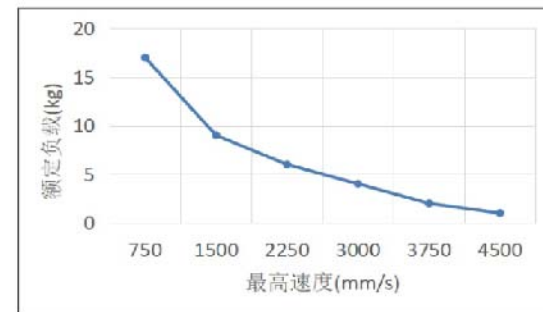

靜態力矩表 Static torque gauge

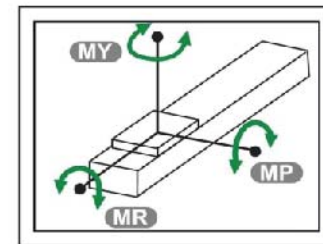

MY	550 (N.M)
MP	550 (N.M)
MR	480 (N.M)

馬達左折-L Motor Left Side

安裝方式一:
安裝螺絲從下往上安裝
*注意鎖緊螺絲裝入滑台的長度不得超過11mm,否則會與內部干涉。

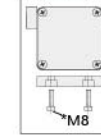

安裝方式二:
打開滑臺上蓋,
安裝螺絲从上往下安裝。

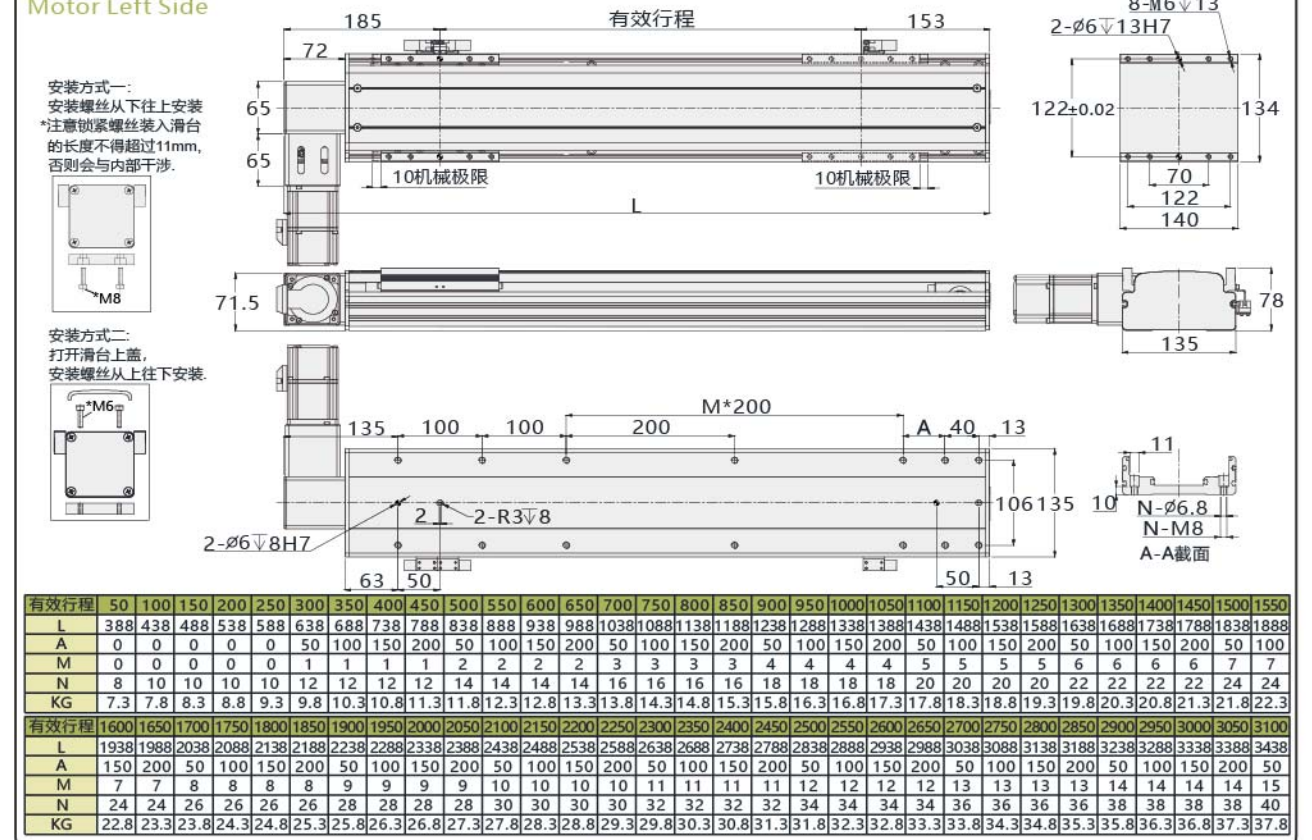
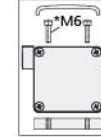

注: 以上不含電機重量。Note: Not including motor weight..

馬達右折-R Motor Right Side

安裝方式一:
安裝螺絲從下往上安裝
*注意鎖緊螺絲裝入滑台的長度不得超過11mm,否則會與內部干涉。

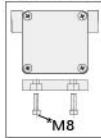

安裝方式二:
打開滑臺上蓋,
安裝螺絲从上往下安裝。

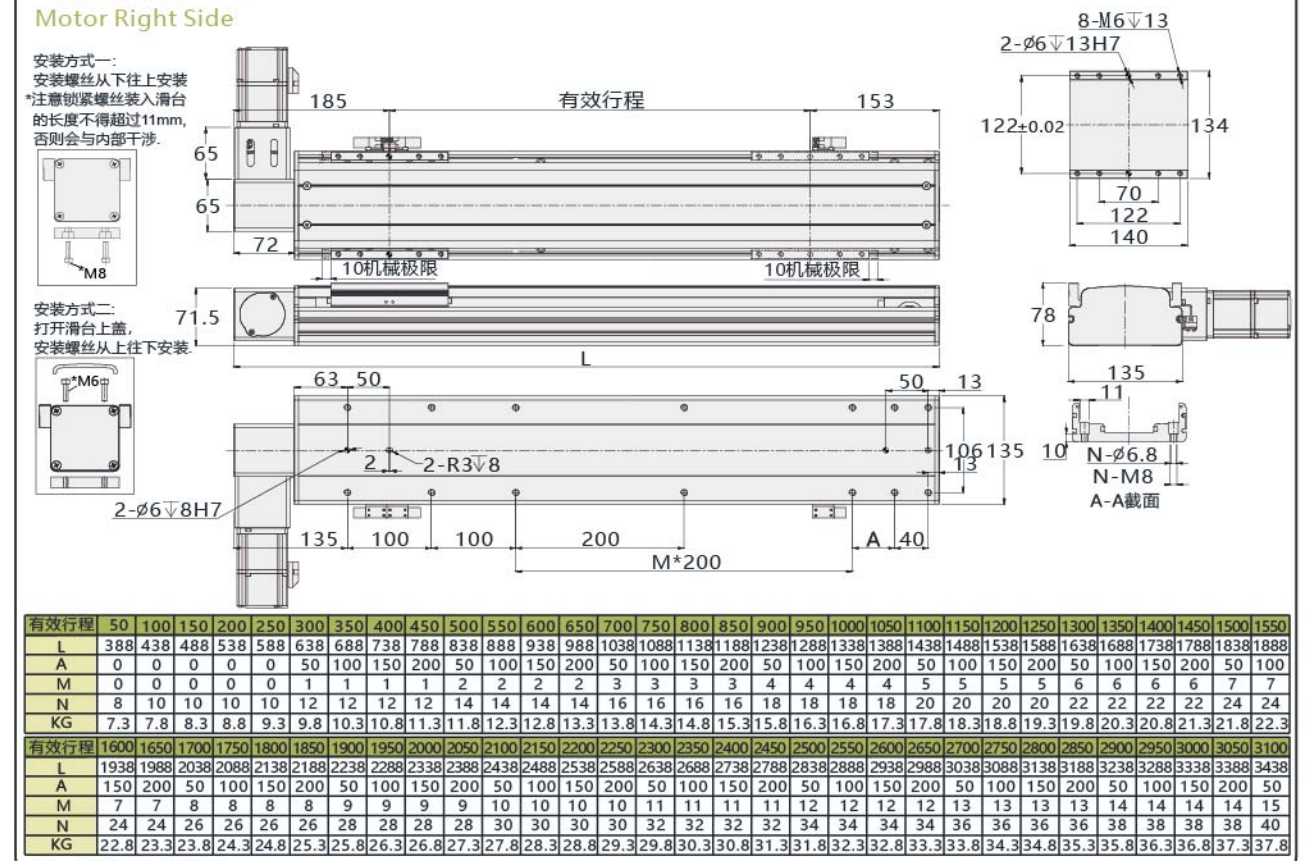
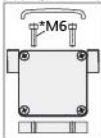

注: 以上不含電機重量。Note: Not including motor weight..

半封閉同步帶滑臺-LB13H

SEMI-CLOSED SYNCHRONIZED BELT SLIDER



馬達安裝方式 Motor direction

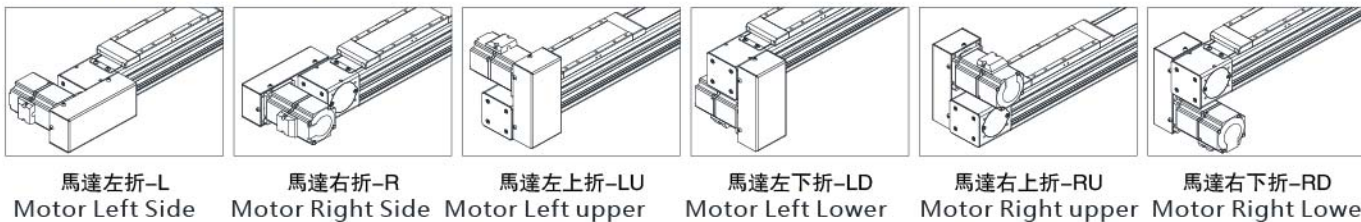

型號表示方式 Guide for Model Selection

LB13H -L45 -S100 - L- ZP40B -T3 _ -001

本體型號 Base Style	*導程 Lead	行程mm Stroke(mm)	馬達方式 Motor way	馬達品牌 Motor Type	馬達功率 Motor power	感應開關數量 Sensor quantity	感應器類型 Sensor type	備註 Non-standard d.c.
	L90 45mm	100-3100	L 左折 R 右折 LU 左上折 LD 左下折 RU 右上折 RD 右下折	P 松下 M 三菱 T 台達 Y 安川 57 57步進電機 其他品牌電機	40 400W	D3 3PCS D2 2PCS D1 1PCS E 无光电开关	无 NPN P PNP	
					剎車 Brakes			
					無 無剎車 B 帶剎車			
				Z 客戶自配電機 無 我司配電機				

*導程：电机旋转一圈，滑台移动的直线距离。

基本型號 Specification

馬達轉速(w) Motor Speed(rpm/mim)	500	1000	1500	2000	2500	3000
最高速度(mm/s) Maximum Payload(mm/s)	375	750	1125	1500	1875	2250
最大負載 (水平使用) Rated load	30	30	23	20	15	10
重複位置精度(mm) Repeatability(mm)	±0.04					
*導程(mm) Lead(mm)	45					
額定推力 (N) Rated thrust(N)	160					
行程範圍 Range of travel(mm)	100-3100MM/50行程遞增					
馬達功率 Motor Output(w)	400					
皮帶寬度(mm) Synchro band width(mm)	20					
導軌規格(mm) Guide specification	W15XH12-2支					
感應器 sensor	EE-SX674(NPN)					

*導程:電機旋轉一圈，滑臺移動的直線距離。

* Guide: the rotation of the motor and the straight distance of the sliding table.

*馬達加減速度時間為0.4S.
motor speed is 0.4S.

*如有特殊行程請先與技術人員聯系。

in case special stroke please contact technical services.

安裝示意圖 Installation Instrations&Dimentions

安裝方式一:

安裝螺絲從上往下安裝

*注意鎖緊螺絲轉入滑臺的長度不得超過11mm，否則會與內部干涉。

Note that the length of the locking screw installed in the slide shall not exceed 10mm, otherwise it will interfere with the internal.

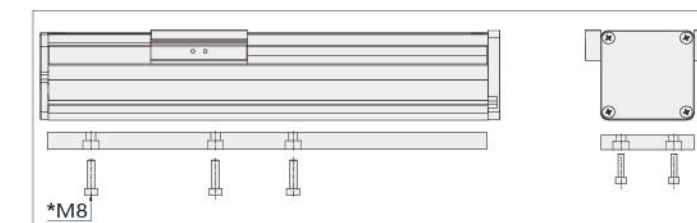

安裝方式二:

打開滑臺上蓋，安裝螺絲從上往下安裝
method 2

Open the top cover of the slide and install the screw from top to bottom

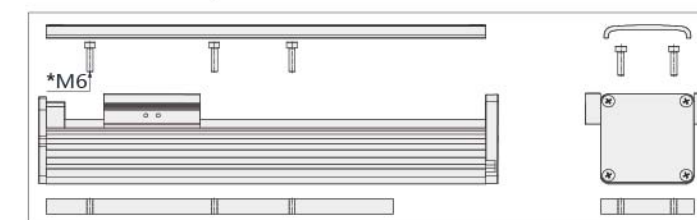

傳感器接線圖 Sensor Wiring diagram

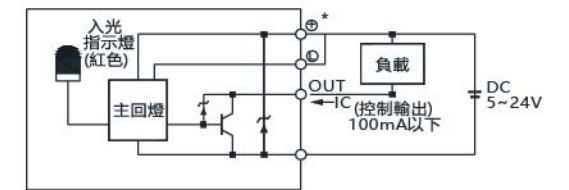

負載與速度 Speed and stroek

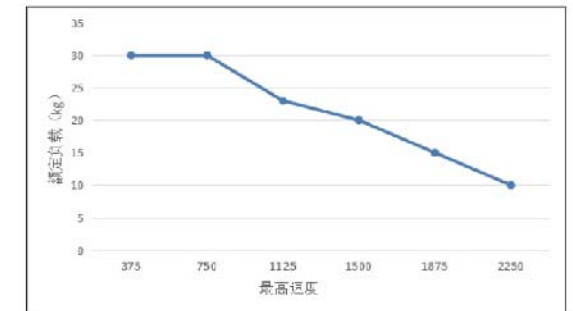

靜態力矩表 Static torque gauge

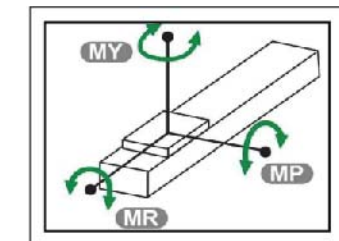

MY	550 (N.M)
MP	550 (N.M)
MR	480 (N.M)

馬達左折-L Motor Left Side

安裝方式一：
安裝螺絲從下往上安裝
*注意鎖緊螺絲裝入滑台
的長度不得超過11mm，
否則會與內部干涉。

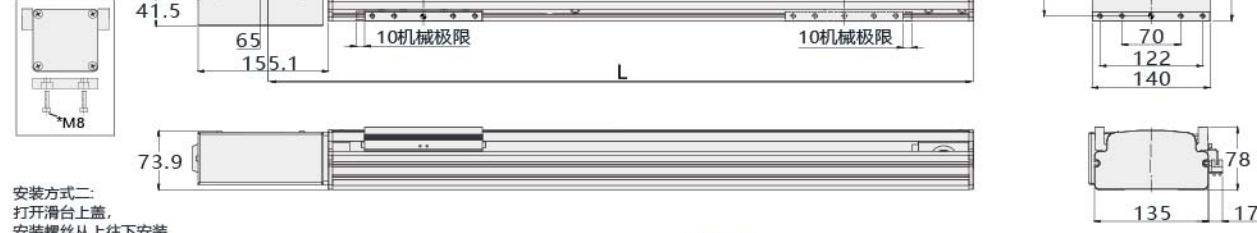

安裝方式二：
打開滑台上蓋，
安裝螺絲從上往下安裝。

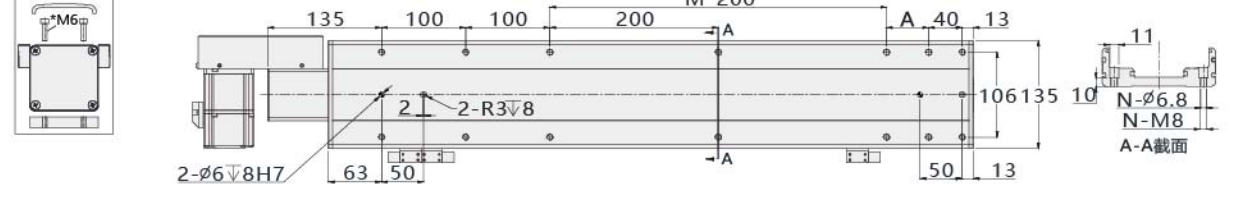

有效行程	50	100	150	200	250	300	350	400	450	500	550	600	650	700	750	800	850	900	950	1000	1050	1100	1150	1200	1250	1300	1350	1400	1450	1500	1550
L	388	438	488	538	588	638	688	738	788	838	888	938	988	1038	1088	1138	1188	1238	1288	1338	1388	1438	1488	1538	1588	1638	1688	1738	1788	1838	1888
A	0	0	0	0	0	50	100	150	200	50	100	150	200	50	100	150	200	50	100	150	200	50	100	150	200	50	100	150	200	50	100
M	0	0	0	0	0	1	1	1	1	1	2	2	2	3	3	3	3	4	4	4	4	5	5	5	5	6	6	6	6	7	7
N	8	10	10	10	10	12	12	12	12	14	14	14	14	16	16	16	16	18	18	18	18	20	20	20	20	22	22	22	22	24	24
KG	7.3	7.8	8.3	8.8	9.3	9.8	10.3	10.8	11.3	11.8	12.3	12.8	13.3	13.8	14.3	14.8	15.3	15.8	16.3	16.8	17.3	17.8	18.3	18.8	19.3	19.8	20.3	20.8	21.3	21.8	22.3
有效行程	1600	1650	1700	1750	1800	1850	1900	1950	2000	2050	2100	2150	2200	2250	2300	2350	2400	2450	2500	2550	2600	2650	2700	2750	2800	2850	2900	2950	3000	3050	3100
L	1938	1988	2038	2088	2138	2188	2238	2288	2338	2388	2438	2488	2538	2588	2638	2688	2738	2788	2838	2888	2938	2988	3038	3088	3138	3188	3238	3288	3338	3388	3438
A	150	200	50	100	150	200	50	100	150	200	50	100	150	200	50	100	150	200	50	100	150	200	50	100	150	200	50	100	150	200	50
M	7	7	8	8	8	8	9	9	9	9	10	10	10	11	11	11	11	12	12	12	13	13	13	13	14	14	14	14	14	15	
N	24	24	26	26	26	28	28	28	28	30	30	30	30	32	32	32	32	34	34	34	34	36	36	36	36	38	38	38	38	40	
KG	22.8	23.3	23.8	24.3	24.8	25.3	25.8	26.3	26.8	27.3	27.8	28.3	28.8	29.3	29.8	30.3	30.8	31.3	31.8	32.3	32.8	33.3	33.8	34.3	34.8	35.3	35.8	36.3	36.8	37.3	37.8

注：以上不含電機重量。Note: Not including motor weight.

馬達左上折-LU Motor Left upper

安裝方式一：
安裝螺絲從下往上安裝
*注意鎖緊螺絲裝入滑台
的長度不得超過11mm，
否則會與內部干涉。



安裝方式二：
打開滑台上蓋，
安裝螺絲從上往下安裝。

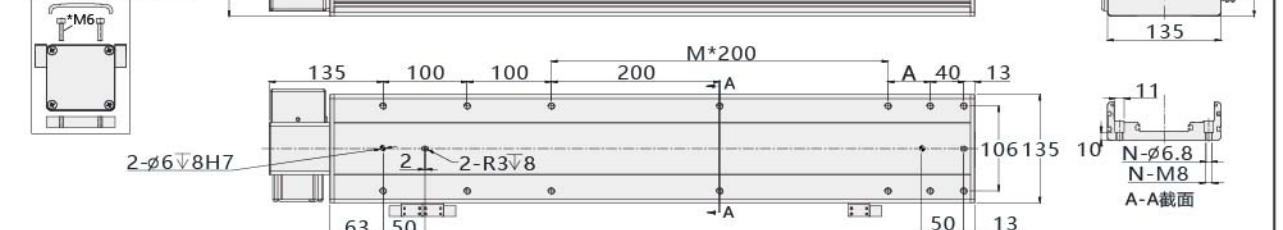

有效行程	50	100	150	200	250	300	350	400	450	500	550	600	650	700	750	800	850	900	950	1000	1050	1100	1150	1200	1250	1300	1350	1400	1450	1500	1550
L	388	438	488	538	588	638	688	738	788	838	888	938	988	1038	1088	1138	1188	1238	1288	1338	1388	1438	1488	1538	1588	1638	1688	1738	1788	1838	1888
A	0	0	0	0	0	50	100	150	200	50	100	150	200	50	100	150	200	50	100	150	200	50	100	150	200	50	100	150	200	50	100
M	0	0	0	0	0	1	1	1	1	1	2	2	2	3	3	3	3	4	4	4	4	5	5	5	5	6	6	6	6	7	7
N	8	10	10	10	10	12	12	12	12	14	14	14	14	16	16	16	16	18	18	18	18	20	20	20	20	22	22	22	22	24	24
KG	7.3	7.8	8.3	8.8	9.3	9.8	10.3	10.8	11.3	11.8	12.3	12.8	13.3	13.8	14.3	14.8	15.3	15.8	16.3	16.8	17.3	17.8	18.3	18.8	19.3	19.8	20.3	20.8	21.3	21.8	22.3
有效行程	1600	1650	1700	1750	1800	1850	1900	1950	2000	2050	2100	2150	2200	2250	2300	2350	2400	2450	2500	2550	2600	2650	2700	2750	2800	2850	2900	2950	3000	3050	3100
L	1938	1988	2038	2088	2138	2188	2238	2288	2338	2388	2438	2488	2538	2588	2638	2688	2738	2788	2838	2888	2938	2988	3038	3088	3138	3188	3238	3288	3338	3388	3438
A	150	200	50	100	150	200	50	100	150	200	50	100	150	200	50	100	150	200	50	100	150	200	50	100	150	200	50	100	150	200	50
M	7	7	8	8	8	8	9	9	9	9	10	10	10	11	11	11	11	12	12	12	13	13	13	13	14	14	14	14	14	15	
N	24	24	26	26	26	28	28	28	28	30	30	30	30	32	32	32	32	34	34	34	34	36	36	36	36	38	38	38	38	40	
KG	22.8	23.3	23.8	24.3	24.8	25.3	25.8	26.3	26.8	27.3	27.8	28.3	28.8	29.3	29.8	30.3	30.8	31.3	31.8	32.3	32.8	33.3	33.8	34.3	34.8	35.3	35.8	36.3	36.8	37.3	37.8

注：以上不含電機重量。Note: Not including motor weight.

馬達右折-R Motor Right Side

安裝方式一：
安裝螺絲從下往上安裝
*注意鎖緊螺絲裝入滑台
的長度不得超過11mm，
否則會與內部干涉。

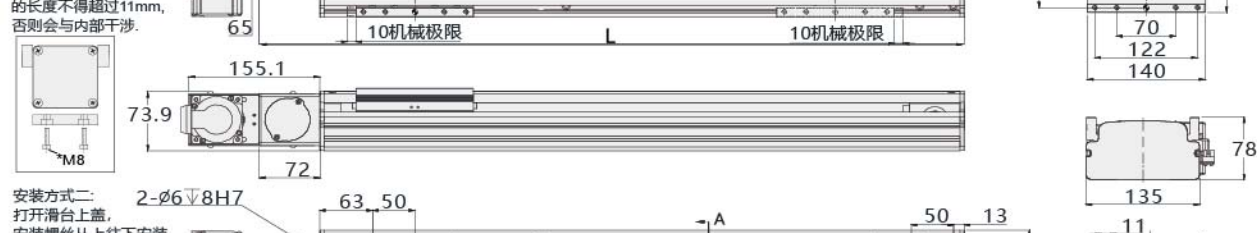

安裝方式二：
打開滑台上蓋，
安裝螺絲從上往下安裝。

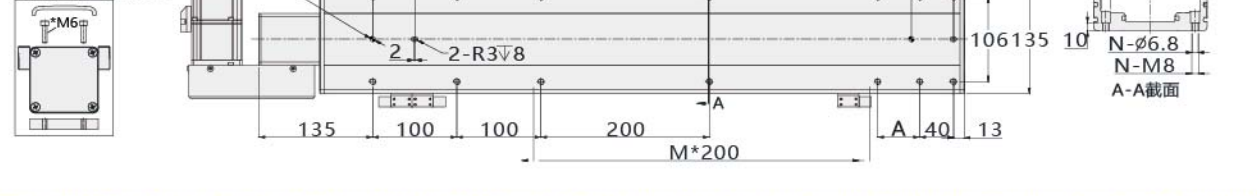

有效行程	50	100	150	200	250	300	350	400	450	500	550	600	650	700	750	800	850	900	950	1000	1050	1100	1150	1200	1250	1300	1350	1400	1450	1500	1550
L	388	438	488	538	588	638	688	738	788	838	888	938	988	1038	1088	1138	1188	1238	1288	1338	1388	1438	1488	1538	1588	1638	1688	1738	1788	1838	1888
A	0	0	0	0	0	50	100	150	200	50	100	150	200	50	100	150	200	50	100	150	200	50	100	150	200	50	100	150	200	50	100
M	0	0	0	0	0	1	1	1	1	1	2	2	2	3	3	3	3	4	4	4	4	5	5	5	5	6	6	6	6	7	7
N	8	10	10	10	10	12	12	12	12	14	14	14	14	16	16	16	16	18	18	18	18	20	20	20	20	22	22	22	22	24	24
KG	7.3	7.8	8.3	8.8	9.3	9.8	10.3	10.8	11.3	11.8	12.3	12.8	13.3	13.8	14.3	14.8	15.3	15.8	16.3	16.8	17.3	17.8	18.3	18.8	19.3	19.8	20.3	20.8	21.3	21.8	22.3
有效行程	1600	1650	1700	1750	1800	1850	1900	1950	2000	2050	2100	2150	2200	2250	2300	2350	2400	2450	2500	2550	2600	2650	2700	2750	2800	2850	2900	2950	3000	3050	3100
L	1938	1988	2038	2088	2138	2188	2238	2288	2338	2388	2438	2488	2538	2588	2638	2688	2738	2788	2838	2888	2938	2988	3038	3088	3138	3188	3238	3288	3338	3388	3438
A	150	200	50	100	150	200	50	100	150	200	50	100	150	200	50	100	150	200	50	100	150	200	50	100	150	200	50	100	150	200	50
M	7	7	8	8	8	8	9	9	9	9	10	10	10	11	11	11	11	12	12	12	13	13	13	13	14	14	14	14	14	15	
N	24	24	26	26	26	28	28	28	28	30	30	30	30	32	32	32	32	34	34	34	34	36	36	36	36	38	38	38	38	40	
KG	22.8	23.3	23.8	24.3	24.8	25.3	25.8	26.3	26.8	27.3	27.8	28.3	28.8	29.3	29.8	30.3	30.8	31.3	31.8	32.3	32.8	33.3	33.8	34.3	34.8	35.3	35.8	36.3	36.8	37.3	37.8

注：以上不含電機重量。Note: Not including motor weight.

馬達左下折-LD Motor Right Side

安裝方式一：
安裝螺絲從下往上安裝
*注意鎖緊螺絲裝入滑台
的長度不得超過11mm，
否則會與內部干涉。

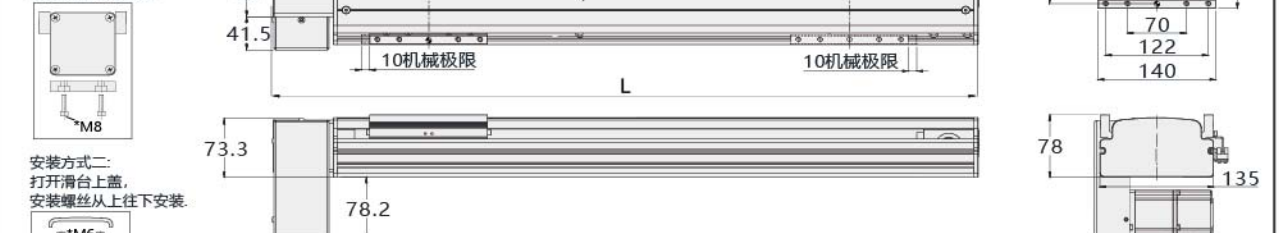

安裝方式二：
打開滑台上蓋，
安裝螺絲從上往下安裝。

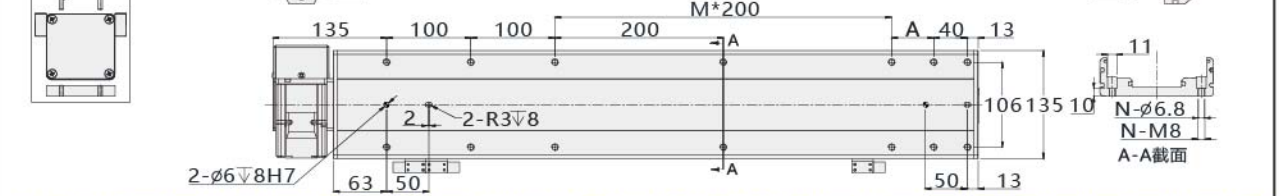

有效行程	50	100	150	200	250	300	350	400	450	500	550	600	650	700	750	800	850	900	950	1000	1050	1100	1150	1200	1250	1300	1350	1400	1450	1500	1550
L	388	438	488	538	588	638	688	738	788	838	888	938	988	1038	1088	1138	1188	1238	1288	1338	1388	1438	1488	1538	1588	1638	1688	1738	1788	1838	1888
A	0	0	0	0	0	50	100	150	200	50	100	150	200	50	100	150	200	50	100	150	200	50	100	150	200	50	100	150	200	50	100
M	0	0	0	0	0	1	1	1	1	1	2	2	2	3	3	3	3	4	4	4	4	5	5	5	5	6	6	6	6	7	7
N	8	10	10	10	10	12	12	12	12	14	14	14	14	16																	

基本型號 Specification

馬達轉速 Motor Speed(rpm/mim)	500	1000	1500	2000	2500	3000
行星減速機 (減速比) Gear reducer	1/3					
最高速度 (mm/s) Maximum Payload(mm/s)	280	560	840	1120	1400	1680
最大負載 (水平使用) Rated load	80	80	80	71	55	45
重複位置精度 (mm) Repeatability (mm)	±0.05					
*導程 (mm) Lead (mm)	100 (配1/3減速機後導程為33.33)					
額定推力 (N) Rated thrust (N)	400					
行程範圍 Range of travel (mm)	100-4500MM/50行程遞增					
馬達功率 Motor Output (w)	750					
皮帶寬度 (mm) Synchro band width (mm)	35					
導軌規格 (mm) Guide specification	W20XH15.5-2支					
連軸器 coupling	20X20					
感應器 sensor	EE-SX674 (NPN)					

*導程: 電機旋轉一圈, 滑臺移動的直線距離。

* Guide: the rotation of the motor and the straight distance of the sliding table.

*馬達加減速度時間為0.4S.
motor speed is 0.4S.

*如有特殊行程請先與技術人員聯系。

in case special stroke please contact technical services.

安裝示意圖 Installation Instratons&Dimentions

安裝方式一:

安裝螺絲從上往下安裝

method 1

fix the screw from bottom to up direction

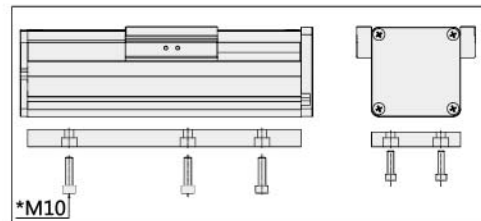

安裝方式二:

打開滑臺上蓋, 安裝螺絲從上往下安裝

method 2

Open the top cover of the slide and install the screw from top to bottom

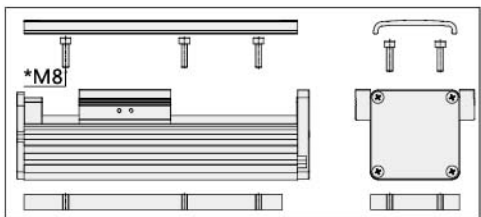

傳感器接綫圖 Sensor Wiring diagram

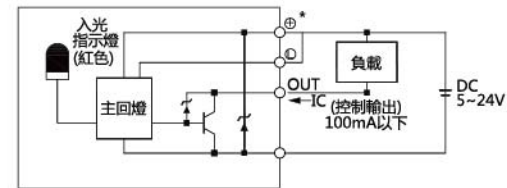

負載與速度 Speed and stroke

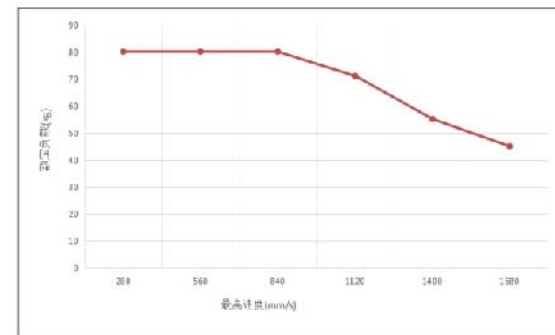

靜態力矩表 Static torque gauge

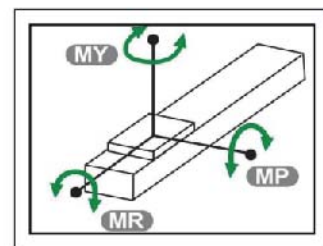

MY	1032(N.M)
MP	1034(N.M)
MR	908(N.M)

馬達左折-L Motor Left Side

安裝方式一:
安裝螺絲從下往上安裝

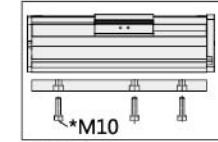

安裝方式二:
打開滑臺上蓋,
安裝螺絲從上往下安裝

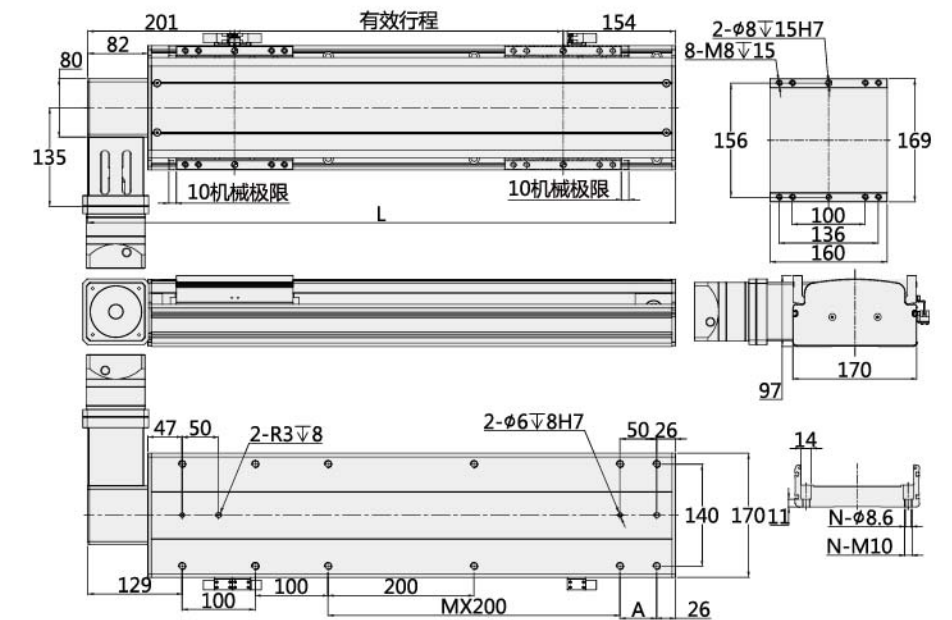
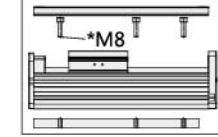

有效行程	300	350	400	450	500	550	600	650	700	750	800	850	900	950	1000	1050	1100	1150	1200	1250	1300	1350	1400	1450	1500	1550	1600	1650
L	655	705	755	805	855	905	955	1005	1055	1105	1155	1205	1255	1305	1355	1405	1455	1505	1555	1605	1655	1705	1755	1805	1855	1905	1955	2005
A	100	150	200	50	100	150	200	50	100	150	200	50	100	150	200	50	100	150	200	50	100	150	200	50	100	150	200	50
M	1	1	1	2	2	2	2	3	3	3	3	4	4	4	5	5	5	5	6	6	6	6	7	7	7	7	7	8
N	10	10	10	12	12	12	12	14	14	14	14	16	16	16	18	18	18	18	20	20	20	22	22	22	22	22	24	
KG	16.1	16.9	17.7	18.5	19.3	20.1	20.9	21.7	22.5	23.3	24.1	24.9	25.7	26.5	27.3	28.1	28.9	29.7	30.5	31.3	32.1	32.9	33.7	34.5	35.3	36.1	36.9	37.7
有效行程	1700	1750	1800	1850	1900	1950	2000	2100	2200	2300	2400	2500	2600	2700	2800	2900	3000	3100	3200	3300	3400	3500	3600	3700	3800	3900	4000	4100
L	2055	2105	2155	2205	2255	2305	2355	2455	2555	2655	2755	2855	2955	3055	3155	3255	3355	3455	3555	3655	3755	3855	3955	4055	4155	4255	4355	4455
A	100	150	200	50	100	150	200	100	200	100	200	100	200	100	200	100	200	100	200	100	200	100	200	100	200	100	200	100
M	8	8	8	9	9	9	9	10	10	11	11	12	12	13	13	14	14	15	15	16	16	17	17	18	18	19	19	20
N	24	24	24	26	26	26	26	28	28	30	30	32	32	34	34	36	36	38	38	40	40	42	42	44	44	46	46	48
KG	38.5	39.3	40.1	40.9	41.7	42.5	43.3	44.9	46.5	48.1	49.7	51.3	52.9	54.5	56.1	57.7	59.3	60.9	62.5	64.1	65.7	67.3	68.9	70.5	72.1	73.7	75.3	76.9

注: 以上不含電機重量。 Note: Not including motor weight..

馬達右折-R Motor Right Side

安裝方式一:
安裝螺絲從下往上安裝

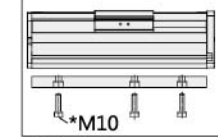

安裝方式二:
打開滑臺上蓋,
安裝螺絲從上往下安裝

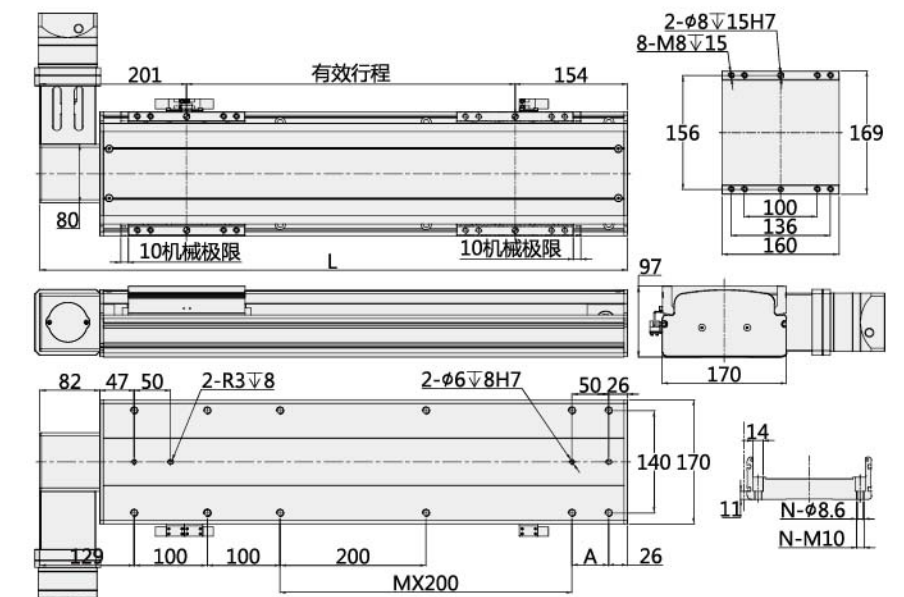
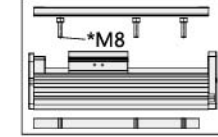

有效行程	300	350	400	450	500	550	600	650	700	750	800	850	900	950	1000	1050	1100	1150	1200	1250	1300	1350	1400	1450	1500	1550	1600	1650
L	655	705	755	805	855	905	955	1005	1055	1105	1155	1205	1255	1305	1355	1405	1455	1505	1555	1605	1655	1705	1755	1805	1855	1905	1955	2005
A	100	150	200	50	100	150	200	50	100	150	200	50	100	150	200	50	100	150	200	50	100	150	200	50	100	150	200	50
M	1	1	1	2	2	2	2	3	3	3	3	4	4	4	5	5	5	5	6	6	6	6	7	7	7	7	7	8
N	10	10	10	12	12	12	12	14	14	14	14	16	16	16	18	18	18	18	20	20	20	22	22	22	22	22	24	
KG	16.1	16.9	17.7	18.5	19.3	20.1	20.9	21.7	22.5	23.3	24.1	24.9	25.7	26.5	27.3	28.1	28.9	29.7	30.5	31.3	32.1	32.9	33.7	34.5	35.3	36.1	36.9	37.7
有效行程	1700	1750	1800	1850	1900	1950	2000	2100	2200	2300	2400	2500	2600	2700	2800	2900	3000	3100	3200	3300	3400	3500	3600	3700	3800	3900	4000	4100
L	2055	2105	2155	2205	2255	2305	2355	2455	2555	2655	2755	2855	2955	3055	3155	3255	3355	3455	3555	3655	3755	3855	3955	4055	4155	4255	4355	4455
A	100	150	200	50	100	150	200	100	200	100	200	100	200	100	200	100	200	100	200	100	200	100	200	100	200	100	200	100
M	8	8	8	9	9	9	9	10	10	11	11	12	12	13	13	14	14	15	15	16	16	17	17	18	18	19	19	20
N	24	24	24	26	26	26	26	28	28	30	30	32	32	34	34	36	36	38	38	40	40	42	42	44	44	46	46	48
KG	38.5	39.3	40.1	40.9	41.7	42.5	43.3	44.9	46.5	48.1	49.7	51.3	52.9	54.5	56.1	57.7	59.3	60.9	62.5	64.1	65.7	67.3	68.9	70.5	72.1	73.7	75.3	76.9

注: 以上不含電機重量。 Note: Not including motor weight..

半封閉同步帶滑臺-LB17H

SEMI-CLOSED SYNCHRONIZED BELT SLIDER

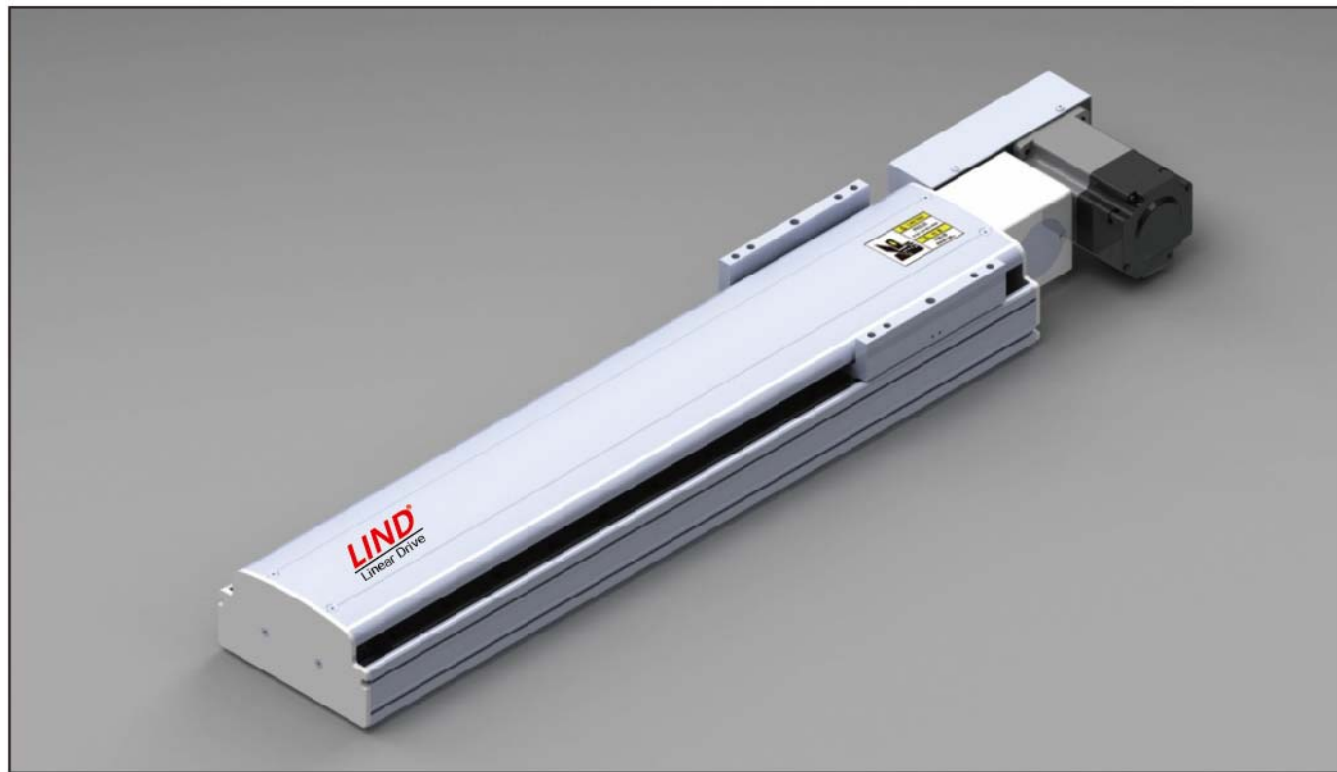

馬達安裝方式 Motor direction

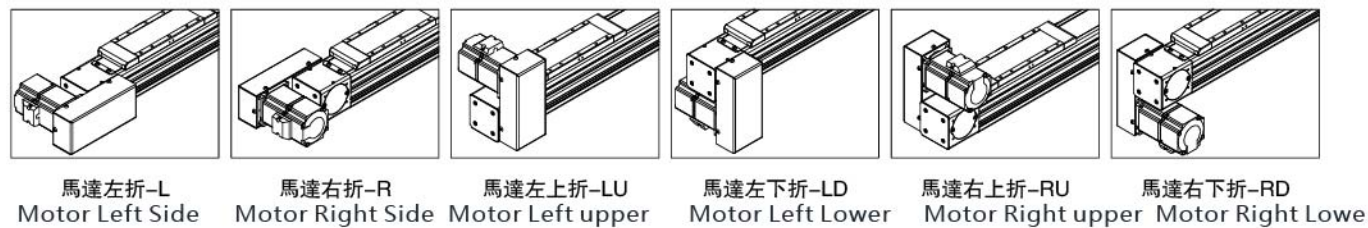

型號表示方式 Guide for Model Selection

LB17H -L50 -S100 - L- ZP75B -T3 _ -001

本體型號 Base Style	*導程 Lead	行程mm Stroke(mm)	馬達方式 Motor way	馬達品牌 Motor Type	馬達功率 Motor power	感應開關數量 Sensor quantity	感應器類型 Sensor type	備註 Non-standard,d.c.
L50	50mm	100-4500	L 左折 R 右折 LU 左上折 LD 左下折 RU 右上折 RD 右下折	P 松下 M 三菱 T 台達 Y 安川 86 57步進電機 其他品牌電機	75 750W 86 86步進 刹車 Brakes 無 無刹車 B 帶刹車	D3 3PCS D2 2PCS D1 1PCS E 无光电开关	无 NPN P PNP	
Z				客戶自配電機				
無				我司配電機				

*導程：电机旋轉一圈，滑台移動的直線距離。

基本型號 Specification

馬達轉速(w) Motor Speed(rpm/mim)	500	1000	1500	2000	2500	3000
最高速度(mm/s) Maximum Payload(mm/s)	416	833	1250	1600	2100	2500
最大負載(水平使用) Rated load	60	60	45	33	25	21
重複位置精度(mm) Repeatability(mm)	±0.04					
*導程(mm) Lead(mm)	50					
額定推力(N) Rated thrust(N)	300					
行程範圍 Range of travel(mm)	100-4500MM/50行程遞增					
馬達功率 Motor Output(w)	750					
皮帶寬度(mm) Synchro band width(mm)	35					
導軌規格(mm) Guide specification	W20XH15.5-2支					
感應器 sensor	EE-SX674(NPN)					

*導程:電機旋轉一圈，滑臺移動的直線距離。

* Guide: the rotation of the motor and the straight distance of the sliding table.

*馬達加減速度時間為0.4S.
motor speed is 0.4S.

*如有特殊行程請先與技術人員聯系。

in case special stroke please contact technical services.

安裝示意圖 Installation Instrations&Dimentions

安裝方式一:

安裝螺絲從上往下安裝

method 1

fix the screw from bottom to up direction

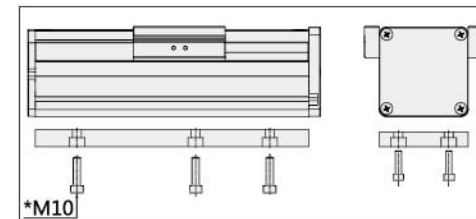

安裝方式二:

打開滑臺上蓋，安裝螺絲從上往下安裝

method 2

Open the top cover of the slide and install the screw from top to bottom

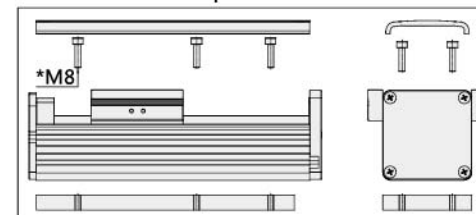

傳感器接綫圖 Sensor Wiring diagram

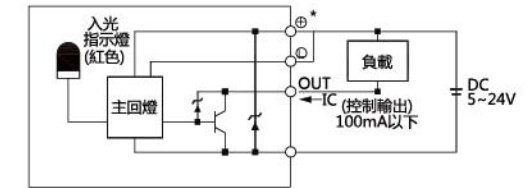

負載與速度 Speed and stroke

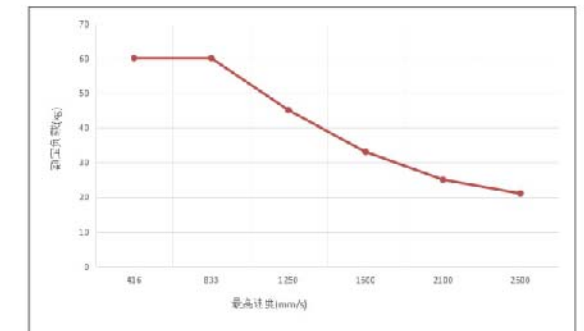

靜態力矩表 Static torque gauge

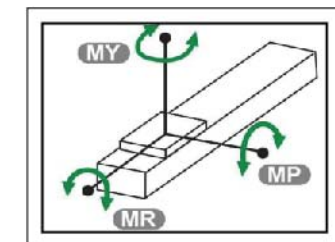

MY	1032(N.M)
MP	1034(N.M)
MR	908(N.M)

馬達左折-L Motor Left Side

安裝方式一：
安裝螺絲從下往上安裝

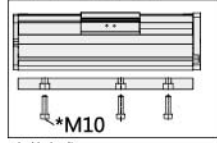

安裝方式二：
打開滑台上蓋，
安裝螺絲從上往下安裝。

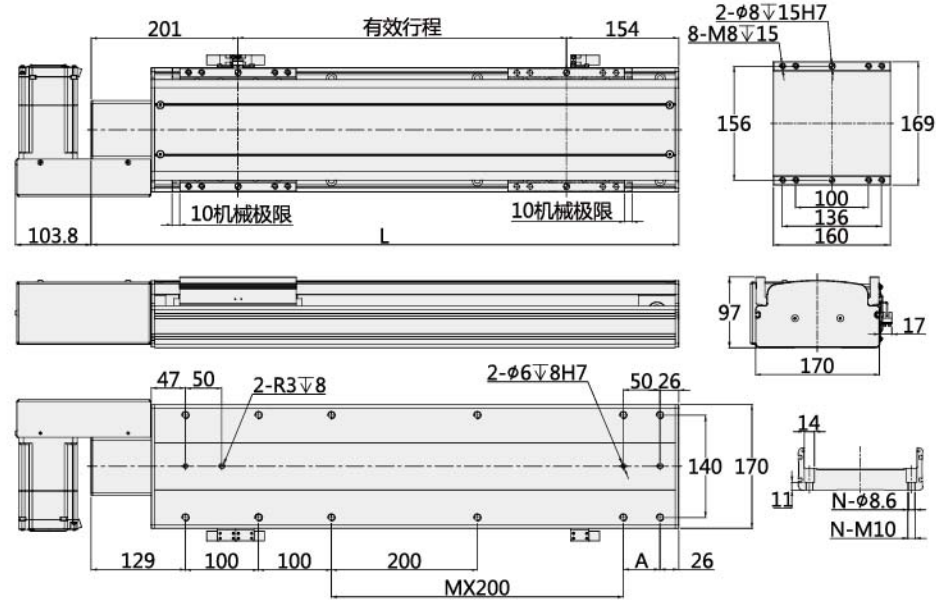
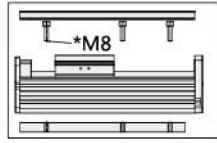

有效行程	300	350	400	450	500	550	600	650	700	750	800	850	900	950	1000	1050	1100	1150	1200	1250	1300	1350	1400	1450	1500	1550	1600	1650
L	655	705	755	805	855	905	955	1005	1055	1105	1155	1205	1255	1305	1355	1405	1455	1505	1555	1605	1655	1705	1755	1805	1855	1905	1955	2005
A	100	150	200	50	100	150	200	50	100	150	200	50	100	150	200	50	100	150	200	50	100	150	200	50	100	150	200	50
M	1	1	1	2	2	2	2	3	3	3	4	4	4	4	5	5	5	5	6	6	6	6	6	7	7	7	7	8
N	10	10	10	12	12	12	12	14	14	14	14	16	16	16	16	18	18	18	18	20	20	20	20	22	22	22	22	24
KG	16.1	16.9	17.7	18.5	19.3	20.1	20.9	21.7	22.5	23.3	24.1	24.9	25.7	26.5	27.3	28.1	28.9	29.7	30.5	31.3	32.1	32.9	33.7	34.5	35.3	36.1	36.9	37.7
有效行程	1700	1750	1800	1850	1900	1950	2000	2100	2200	2300	2400	2500	2600	2700	2800	2900	3000	3100	3200	3300	3400	3500	3600	3700	3800	3900	4000	4100
L	2055	2105	2155	2205	2255	2305	2355	2405	2455	2505	2555	2605	2655	2705	2755	2805	2855	2905	2955	3005	3055	3105	3155	3205	3255	3305	3355	3405
A	100	150	200	50	100	150	200	50	100	150	200	50	100	150	200	50	100	150	200	50	100	150	200	50	100	150	200	50
M	8	8	8	9	9	9	9	10	10	10	11	11	12	12	13	13	14	14	15	15	16	16	17	17	18	18	19	19
N	24	24	24	26	26	26	26	28	28	28	30	30	32	32	34	34	36	36	38	38	40	40	42	42	44	44	46	46
KG	38.5	39.3	40.1	40.9	41.7	42.5	43.3	44.1	44.9	45.7	46.5	47.3	48.1	48.9	49.7	50.5	51.3	52.1	52.9	53.7	54.5	55.3	56.1	56.9	57.7	58.5	59.3	60.1

注：以上不含電機重量。Note: Not including motor weight..

馬達左上折-LU Motor Left upper

安裝方式一：
安裝螺絲從下往上安裝

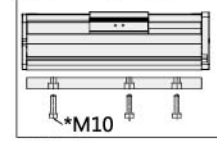

安裝方式二：
打開滑台上蓋，
安裝螺絲從上往下安裝。

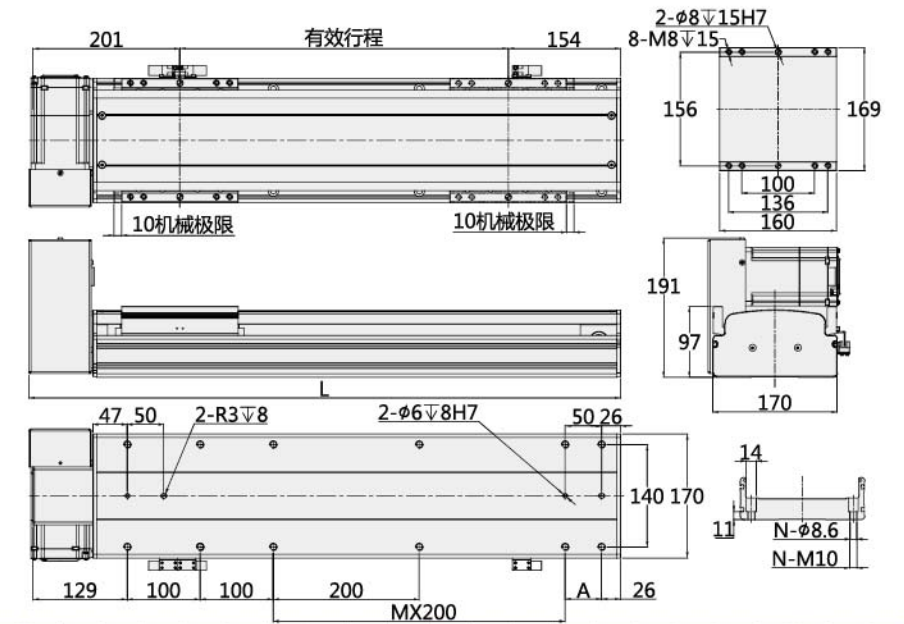
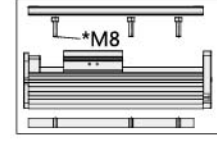

有效行程	300	350	400	450	500	550	600	650	700	750	800	850	900	950	1000	1050	1100	1150	1200	1250	1300	1350	1400	1450	1500	1550	1600	1650
L	660	710	760	810	860	910	960	1010	1060	1110	1160	1210	1260	1310	1360	1410	1460	1510	1560	1610	1660	1710	1760	1810	1860	1910	1960	2010
A	100	150	200	50	100	150	200	50	100	150	200	50	100	150	200	50	100	150	200	50	100	150	200	50	100	150	200	50
M	1	1	1	2	2	2	2	3	3	3	3	4	4	4	4	5	5	5	5	6	6	6	6	7	7	7	7	8
N	10	10	10	12	12	12	12	14	14	14	14	16	16	16	16	18	18	18	18	20	20	20	20	22	22	22	22	24
KG	16.1	16.9	17.7	18.5	19.3	20.1	20.9	21.7	22.5	23.3	24.1	24.9	25.7	26.5	27.3	28.1	28.9	29.7	30.5	31.3	32.1	32.9	33.7	34.5	35.3	36.1	36.9	37.7
有效行程	1700	1750	1800	1850	1900	1950	2000	2100	2200	2300	2400	2500	2600	2700	2800	2900	3000	3100	3200	3300	3400	3500	3600	3700	3800	3900	4000	4100
L	2060	2110	2160	2210	2260	2310	2360	2410	2460	2510	2560	2610	2660	2710	2760	2810	2860	2910	2960	3010	3060	3110	3160	3210	3260	3310	3360	3410
A	100	150	200	50	100	150	200	50	100	150	200	50	100	150	200	50	100	150	200	50	100	150	200	50	100	150	200	50
M	8	8	8	9	9	9	9	10	10	10	11	11	12	12	13	13	14	14	15	15	16	16	17	17	18	18	19	19
N	24	24	24	26	26	26	26	28	28	28	30	30	32	32	34	34	36	36	38	38	40	40	42	42	44	44	46	46
KG	38.5	39.3	40.1	40.9	41.7	42.5	43.3	44.1	44.9	45.7	46.5	47.3	48.1	48.9	49.7	50.5	51.3	52.1	52.9	53.7	54.5	55.3	56.1	56.9	57.7	58.5	59.3	60.1

注：以上不含電機重量。Note: Not including motor weight..

馬達右折-R Motor Right Side

安裝方式一：
安裝螺絲從下往上安裝

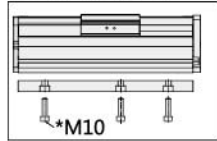

安裝方式二：
打開滑台上蓋，
安裝螺絲從上往下安裝。

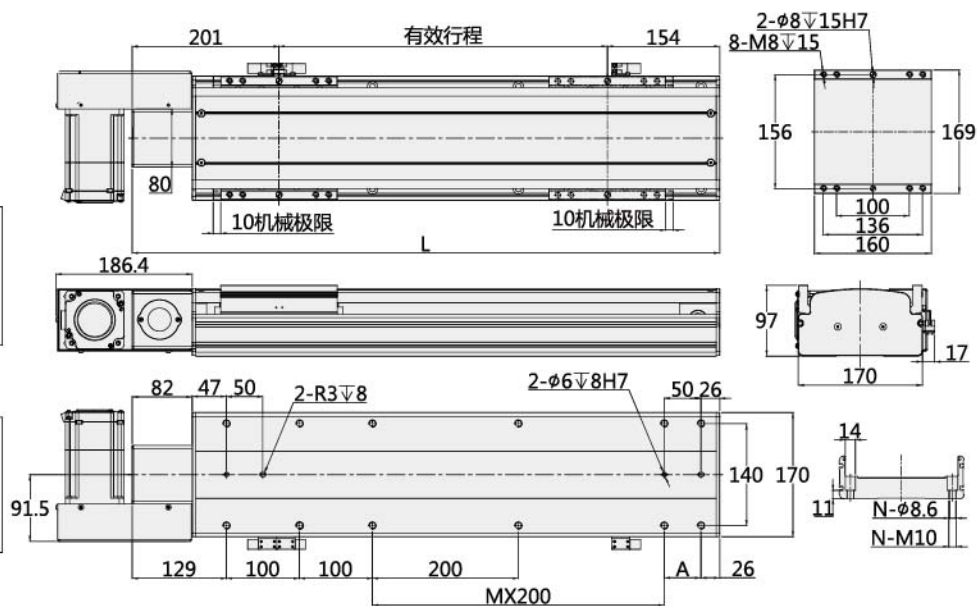
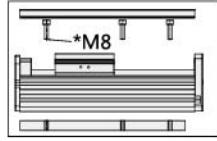

有效行程	300	350	400	450	500	550	600	650	700	750	800	850	900	950	1000	1050	1100	1150	1200	1250	1300	1350	1400	1450	1500	1550	1600	1650
L	655	705	755	805	855	905	955	1005	1055	1105	1155	1205	1255	1305	1355	1405	1455	1505	1555	1605	1655	1705	1755	1805	1855	1905	1955	2005
A	100	150	200	50	100	150	200	50	100	150	200	50	100	150	200	50	100	150	200	50	100	150	200	50	100	150	200	50
M	1	1	1	2	2	2	2	3	3	3	4	4	4	4	5	5	5	5	6	6	6	6	7	7	7	7	8	
N	10	10	10	12	12	12	12	14	14	14	14	16	16	16	16	18	18	18	18	20	20	20	20	22	22	22	22	24
KG	16.1	16.9	17.7	18.5	19.3	20.1	20.9	21.7	22.5	23.3	24.1	24.9	25.7	26.5	27.3	28.1	28.9	29.7	30.5	31.3	32.1	32.9	33.7	34.5	35.3	36.1	36.9	37.7
有效行程	1700	1750	1800	1850	1900	1950	2000	2100	2200	2300	2400	2500	2600	2700	2800	2900	3000	3100	3200	3300	3400	3500	3600	3700	3800	3900	4000	4100
L	2055	2105	2155	2205	2255	2305	2355	2405	2455	2505	2555	2605	2655	2705	2755	2805	2855	2905	2955	3005	3055	3105	3155	3205	3255	3305	3355	3405
A	100	150	200	50	100	150	200	50	100	150	200	50	100	150	200	50	100	150	200	50	100	150	200	50	100	150	200	50
M	8	8	8	9	9	9	9	10	10	10	11	11	12	12	13	13	14	14	15	15	16	16	17	17	18	18	19	19
N	24	24	24	26	26	26	26	28	28	28	30	30	32	32	34	34	36	36	38	38	40	40	42	42	44	44	46	46
KG	38.5	39.3	40.1	40.9	41.7	42.5	43.3	44.1	44.9	45.7	46.5	47.3	48.1	48.9	49.7	50.5	51.3	52.1	52.9	53.7	54.5	55.3	56.1	56.9	57.7	58.5	59.3	60.1

注：以上不含電機重量。Note: Not including motor weight..

馬達左下折-LD Motor Right Side

安裝方式一：
安裝螺絲從下往上安裝

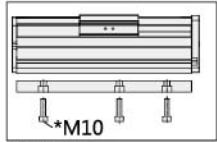

安裝方式二：
打開滑台上蓋，
安裝螺絲從上往下安裝。

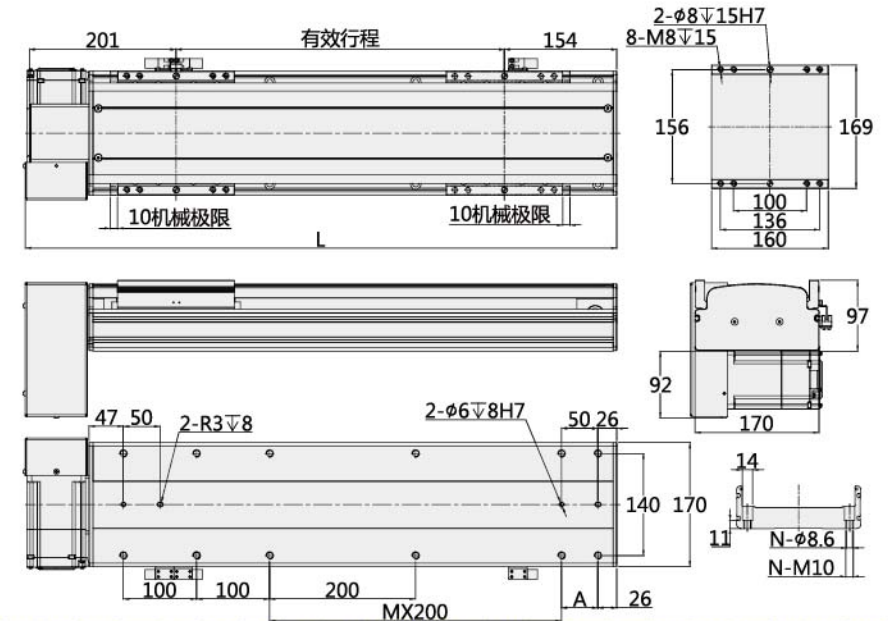
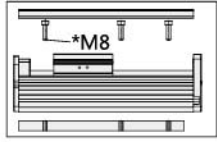

有效行程	300	350	400	450	500	550	600	650	700	750	800	850	900	950	1000	1050	1100	1150	1200	1250	1300	1350	1400	1450	1500	1550	1600	1650
L	660	710	760	810	860	910	960	1010	1060	1110	1160	1210	1260	1310	1360	1410	1460	1510	1560	1610	1660	1710	1760	1810	1860	1910	1960	2010
A	100	150	200	50	100	150	200	50	100	150	200	50	100	150	200	50	100	150	200	50	100	150	200	50	100	150	200	50
M	1	1	1	2	2	2	2	3	3	3	3	4	4	4	4	5	5	5	5	6	6	6	6	7	7	7	7	8
N	10	10	10	12	12	12	12	14	14	14	14	16	16	16	16	18	18	18	18	20	20	20	20	22	22	22	22	24
KG	16.1	16.9	17.7	18.5	19.3	20.1	20.9	21.7	22.5	23.3	24.1	24.9	25.7	26.5	27.3	28.1	28.9	29.7	30.5	31.3	32.1	32.9	33.7	34.5	35.3	36.1	36.9	37.7
有效行程	1700	1750	1800	1850	1900	1950	2000	2100	2200	2300	240																	

馬達右上折-RU
Motor Left Side

安裝方式一：
安裝螺絲從下往上安裝

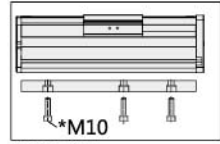

安裝方式二：
打開滑台上蓋，
安裝螺絲從上往下安裝

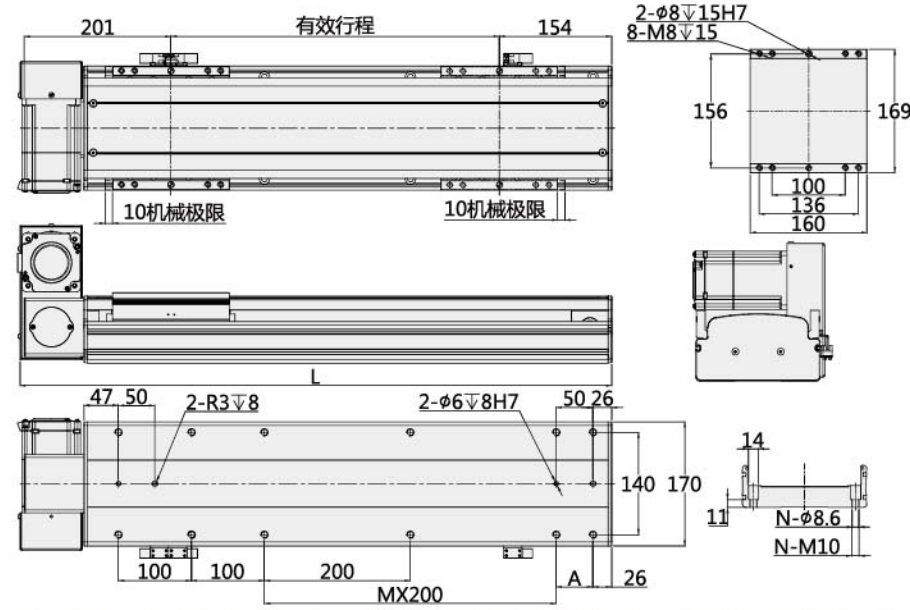
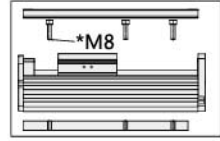

有效行程	300	350	400	450	500	550	600	650	700	750	800	850	900	950	1000	1050	1100	1150	1200	1250	1300	1350	1400	1450	1500	1550	1600	1650
L	660	710	760	810	860	910	960	1010	1060	1110	1160	1210	1260	1310	1360	1410	1460	1510	1560	1610	1660	1710	1760	1810	1860	1910	1960	2010
A	100	150	200	50	100	150	200	50	100	150	200	50	100	150	200	50	100	150	200	50	100	150	200	50	100	150	200	50
M	1	1	1	2	2	2	2	3	3	3	3	4	4	4	4	5	5	5	5	6	6	6	6	7	7	7	7	8
N	10	10	10	12	12	12	12	14	14	14	14	16	16	16	16	18	18	18	18	20	20	20	20	22	22	22	22	24
KG	16.1	16.9	17.7	18.5	19.3	20.1	20.9	21.7	22.5	23.3	24.1	24.9	25.7	26.5	27.3	28.1	28.9	29.7	30.5	31.3	32.1	32.9	33.7	34.5	35.3	36.1	36.9	37.7
有效行程	1700	1750	1800	1850	1900	1950	2000	2100	2200	2300	2400	2500	2600	2700	2800	2900	3000	3100	3200	3300	3400	3500	3600	3700	3800	3900	4000	4100
L	2060	2110	2160	2210	2260	2310	2360	2460	2560	2660	2760	2860	2960	3060	3160	3260	3360	3460	3560	3660	3760	3860	3960	4060	4160	4260	4360	4460
A	100	150	200	50	100	150	200	100	200	100	200	100	200	100	200	100	200	100	200	100	200	100	200	100	200	100	200	100
M	8	8	8	9	9	9	9	10	10	11	11	12	12	13	13	14	14	15	15	16	16	17	17	18	18	19	19	20
N	24	24	24	26	26	26	26	28	28	30	30	32	32	34	34	36	36	38	38	40	40	42	42	44	44	46	46	48
KG	38.5	39.3	40.1	40.9	41.7	42.5	43.3	44.9	46.5	48.1	49.7	51.3	52.9	54.5	56.1	57.7	59.3	60.9	62.5	64.1	65.7	67.3	68.9	70.5	72.1	73.7	75.3	76.9

注：以上不含電機重量。 Note: Not including motor weight..

馬達右下折-RD
Motor Right Side

安裝方式一：
安裝螺絲從下往上安裝

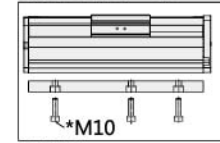

安裝方式二：
打開滑台上蓋，
安裝螺絲從上往下安裝

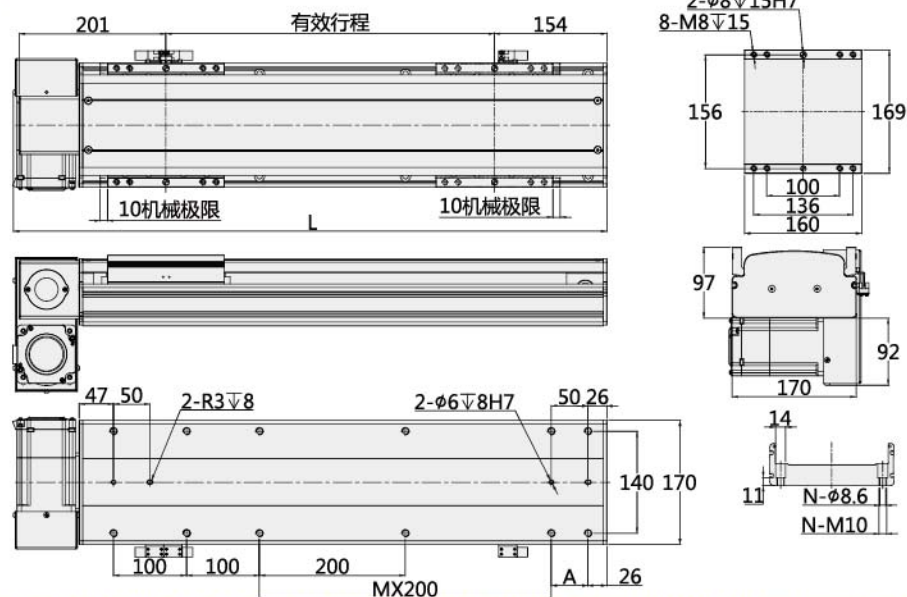
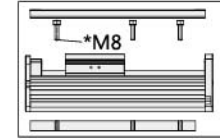

有效行程	300	350	400	450	500	550	600	650	700	750	800	850	900	950	1000	1050	1100	1150	1200	1250	1300	1350	1400	1450	1500	1550	1600	1650
L	660	710	760	810	860	910	960	1010	1060	1110	1160	1210	1260	1310	1360	1410	1460	1510	1560	1610	1660	1710	1760	1810	1860	1910	1960	2010
A	100	150	200	50	100	150	200	50	100	150	200	50	100	150	200	50	100	150	200	50	100	150	200	50	100	150	200	50
M	1	1	1	2	2	2	2	3	3	3	3	4	4	4	4	5	5	5	5	6	6	6	6	7	7	7	7	8
N	10	10	10	12	12	12	12	14	14	14	14	16	16	16	16	18	18	18	18	20	20	20	20	22	22	22	22	24
KG	16.1	16.9	17.7	18.5	19.3	20.1	20.9	21.7	22.5	23.3	24.1	24.9	25.7	26.5	27.3	28.1	28.9	29.7	30.5	31.3	32.1	32.9	33.7	34.5	35.3	36.1	36.9	37.7
有效行程	1700	1750	1800	1850	1900	1950	2000	2100	2200	2300	2400	2500	2600	2700	2800	2900	3000	3100	3200	3300	3400	3500	3600	3700	3800	3900	4000	4100
L	2060	2110	2160	2210	2260	2310	2360	2460	2560	2660	2760	2860	2960	3060	3160	3260	3360	3460	3560	3660	3760	3860	3960	4060	4160	4260	4360	4460
A	100	150	200	50	100	150	200	100	200	100	200	100	200	100	200	100	200	100	200	100	200	100	200	100	200	100	200	100
M	8	8	8	9	9	9	9	10	10	11	11	12	12	13	13	14	14	15	15	16	16	17	17	18	18	19	19	20
N	24	24	24	26	26	26	26	28	28	30	30	32	32	34	34	36	36	38	38	40	40	42	42	44	44	46	46	48
KG	38.5	39.3	40.1	40.9	41.7	42.5	43.3	44.9	46.5	48.1	49.7	51.3	52.9	54.5	56.1	57.7	59.3	60.9	62.5	64.1	65.7	67.3	68.9	70.5	72.1	73.7	75.3	76.9

注：以上不含電機重量。 Note: Not including motor weight..

馬達安裝方式 Motor direction

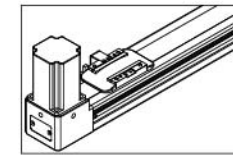

馬達上折-BU
Motor Left Side

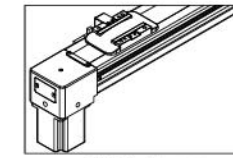

馬達上折-BD
Motor Right Side

型號表示方式 Guide for Model Selection

LSC6 -L42 -S100 - BD- ZP10B -T3_ -001

本體型號 Base Style	*導程 Lead	行程mm Stroke(mm)	馬達方式 Motor way	馬達品牌 Motor Type	馬達功率 Motor power	感應開關數量 Sensor quantity	感應器類型 Sensor type	備註 Non-standard, d.c.
L42	42mm	100-800	BU 上折 BD 下折	P 松下 M 三菱 T 台達 Y 安川 其他品牌電機	10 100W 57 57步進電機	D3 3PCS D2 2PCS D1 1PCS E 无光电开关	无 NPN P PNP	
			Z 客戶自配電機 無 我司配電機		剎車 Brakes 無 無剎車 B 帶剎車			

*導程：电机旋轉一圈，滑台移動的直線距離。

基本型號 Specification

馬達轉速(w) Motor Speed(rpm/mim)	57(57步進電機)	100W(100W伺服電機)
最高速度(mm/s) Maximum Payload(mm/s)	333	2000
最大負載 (水平使用) Rated load	8	3
重複位置精度(mm) Repeatability(mm)	±0.04	
*導程(mm) Lead(mm)	42	
額定推力 (N) Rated thrust(N)	50	40
行程範圍 Range of travel(mm)	50-800MM/50行程遞增	
皮帶寬度(mm) Synchro band width(mm)	15	
導軌規格(mm) Guide specification	W42XH9.5	
感應器 sensor	EE-SX674(NPN)	

*導程:電機旋轉一圈,滑臺移動的直線距離。

* Guide: the rotation of the motor and the straight distance of the sliding table.

*馬達加減速度時間為0.4S.
motor speed is 0.4S.

*如有特殊行程請先與技術人員聯繫。

in case special stroke please contact technical services.

安裝示意圖 Installation Instratons&Dimentions

安裝方式一:

安裝螺絲從上往下安裝

method 1

fix the screw from bottom to up direction

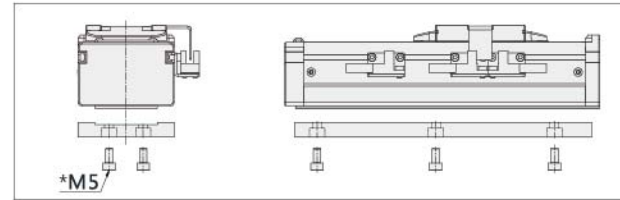

注意鎖緊螺絲裝入滑臺的長度不得超過9mm, 否則會與內部幹啥。

Note that the length of the locking screw in the sliding platform shall not exceed 9 mm.

Otherwise, what will be done with the interior?

傳感器接綫圖 Sensor Wiring diagram

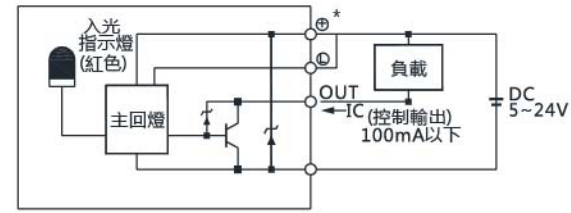

靜態力矩表 Static torque gauge

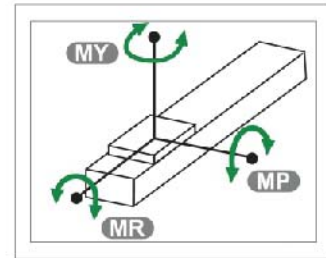

MY	53 (N.M)
MP	60 (N.M)
MR	75 (N.M)

馬達上折-BU Motor Upper Side

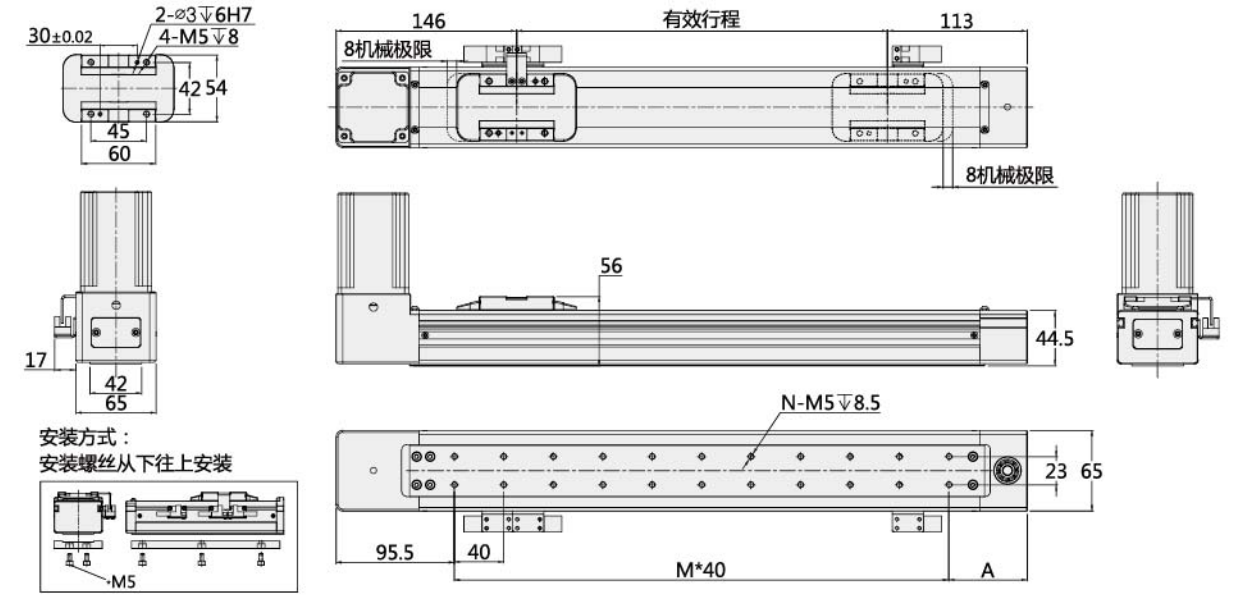

有效行程	100	150	200	250	300	350	400	450	500	550	600	650	700	750	800
L	359	409	459	509	559	609	659	709	759	809	859	909	959	1009	1059
A	63	73	83	53	63	73	83	53	63	73	83	53	63	73	83
M	5	6	7	9	10	11	12	14	15	16	17	19	20	21	22
N	12	14	16	20	22	24	26	30	32	34	36	40	42	44	46
KG	2.3	2.4	2.5	2.6	2.7	2.8	2.9	3.0	3.1	3.2	3.3	3.4	3.5	3.6	3.7

注: 以上不含電機重量 Note: Not including motor weight.

如有特殊行程請先與技術人員聯繫 in case special stroke please contact technical services.

馬達上折-BD Motor Down Side

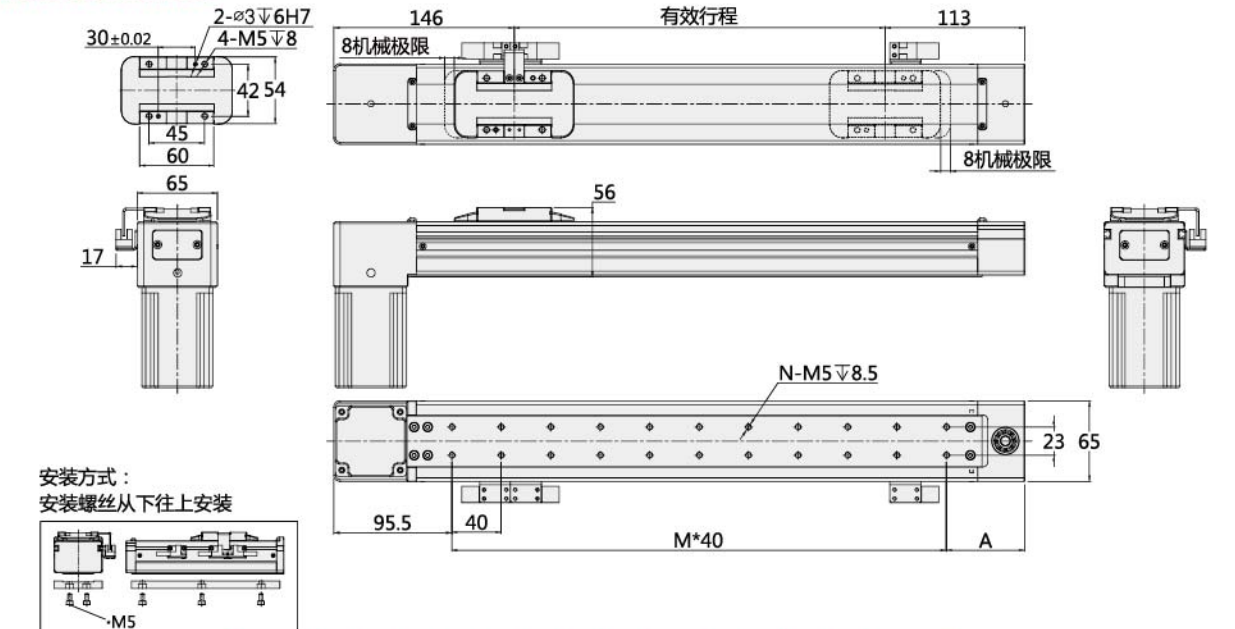

有效行程	100	150	200	250	300	350	400	450	500	550	600	650	700	750	800
L	359	409	459	509	559	609	659	709	759	809	859	909	959	1009	1059
A	63	73	83	53	63	73	83	53	63	73	83	53	63	73	83
M	5	6	7	9	10	11	12	14	15	16	17	19	20	21	22
N	12	14	16	20	22	24	26	30	32	34	36	40	42	44	46
KG	2.3	2.4	2.5	2.6	2.7	2.8	2.9	3.0	3.1	3.2	3.3	3.4	3.5	3.6	3.7

密封式同步帶滑臺-LBC10

SEALED SYNCHRONOUS BELT SLIDE

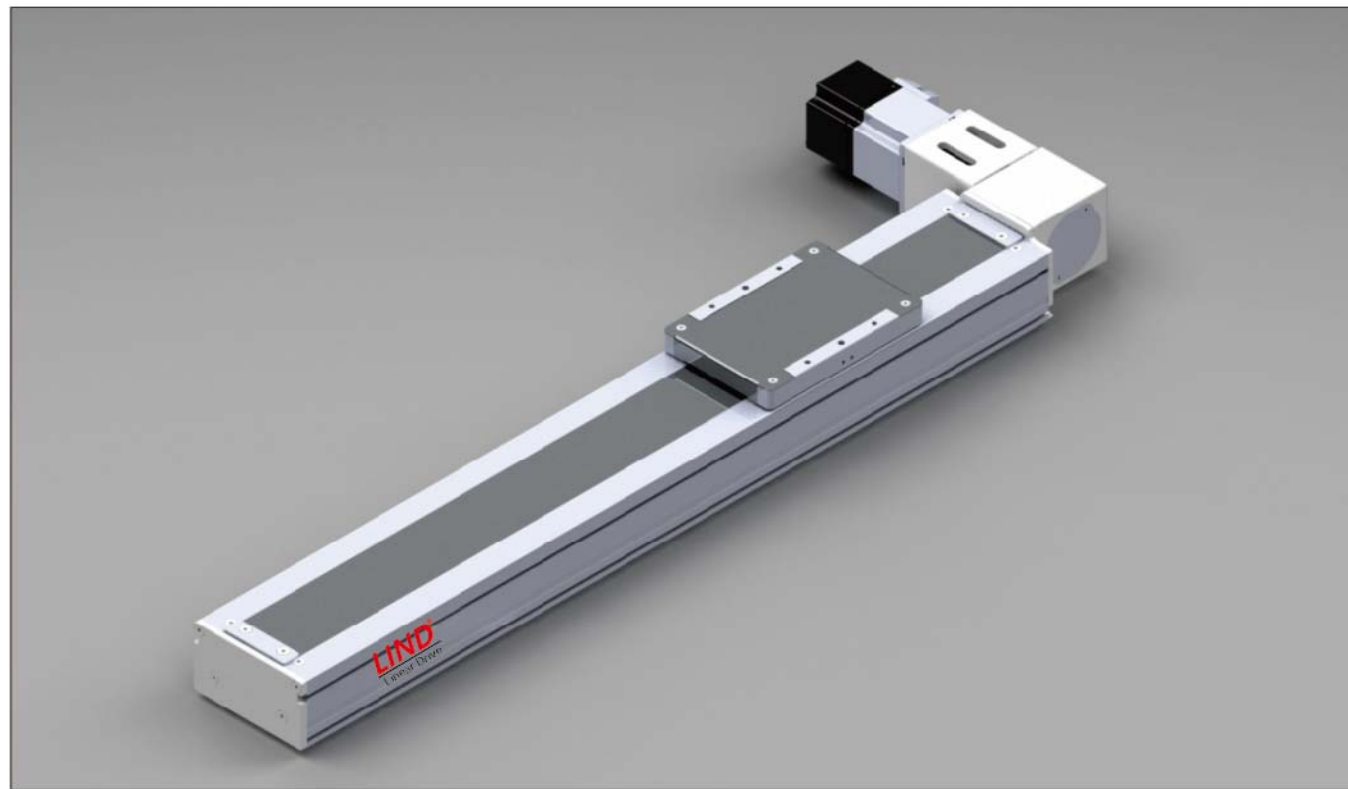

基本型號 Specification

馬達轉速 Motor Speed(rpm/min)	500	1000	1500	2000	2500	3000
最高速度 (mm/s) Maximum Payload(mm/s)	750	1500	2250	3000	3750	4500
最大負載 (水平使用) Rated load	15	8	5	3	2	1
重複位置精度(mm) Repeatability(mm)	±0.04					
*導程(mm) Lead(mm)	90					
額定推力 (N) Rated thrust(N)	81					
行程範圍 Range of travel(mm)	100-2550MM/50行程遞增					
馬達功率 Motor Output(w)	400					
皮帶寬度(mm) Synchro band width(mm)	20					
導軌規格(mm) Guide specification	W15XH12-2支					
連軸器 coupling	12X14					
感應器 sensor	EE-SX674(NPN)					

*導程:電機旋轉一圈, 滑臺移動的直線距離.

* Guide: the rotation of the motor and the straight distance of the sliding table.

*馬達加減速度時間為0.4S.
motor speed is 0.4S.

*如有特殊行程請先與技術人員聯系.
in case special stroke please contact technical services.

傳感器接綫圖 Sensor Wiring diagram

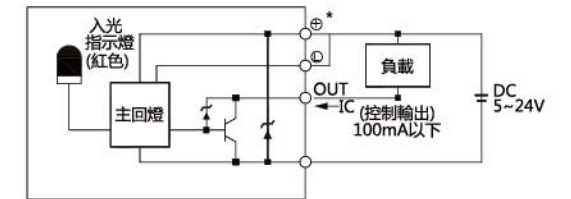

負載與速度 Speed and stroke

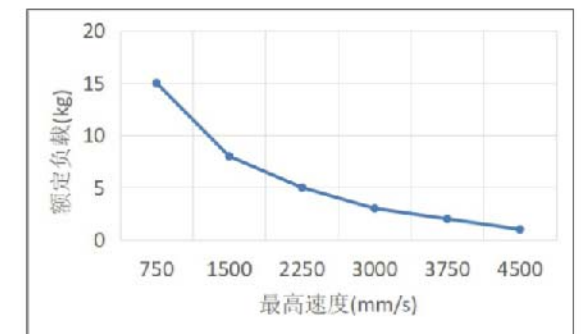

馬達安裝方式 Motor direction

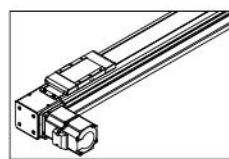

馬達左折-L
Motor Left Side

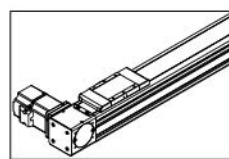

馬達右折-R
Motor Right Side

型號表示方式 Guide for Model Selection

LBC10 -L90 -S100 - L- ZP40B -T3 _ -001

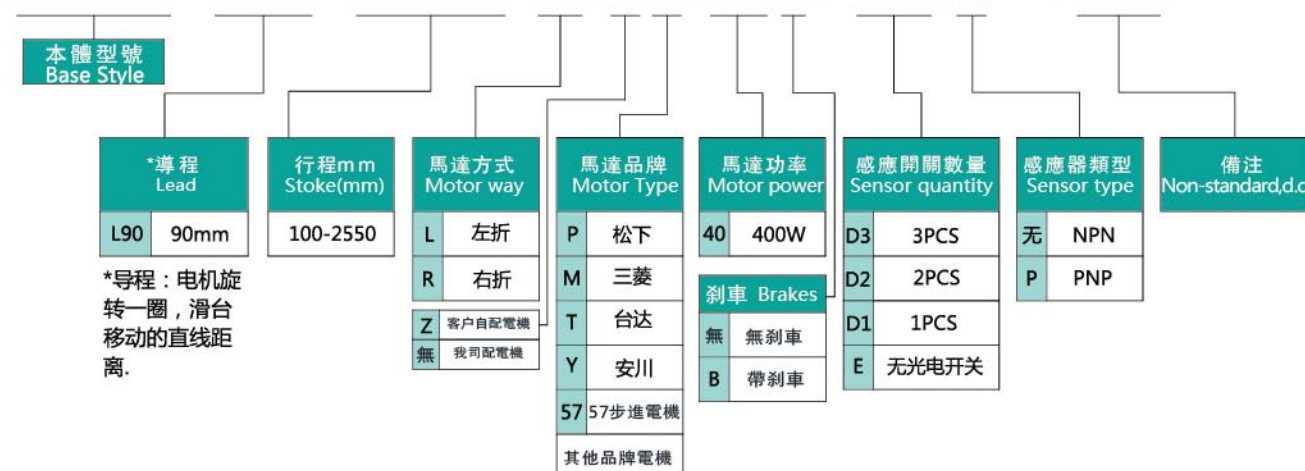

安裝示意圖 Installation Instrations&Dimentions

安裝方式一:

安裝螺絲從下往上安裝

注意鎖緊螺絲裝入滑臺的長度不得超過11mm, 否則會與內部幹啥。

Note that the length of the locking screw installed in the slide shall not exceed 10mm, otherwise it will interfere with the internal.

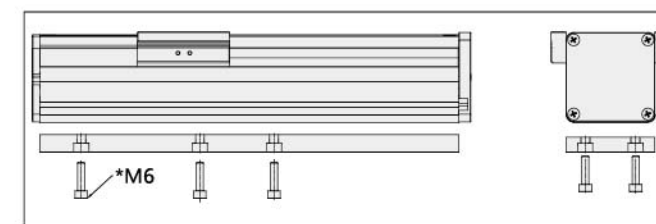

靜態力矩表 Static torque gauge

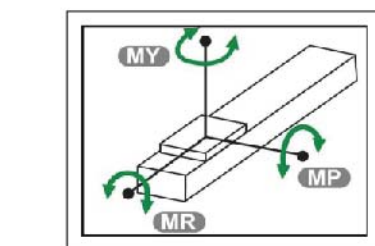

MY	160 (N.M)
MP	160 (N.M)
MR	140 (N.M)

馬達左折-L Motor Left Side

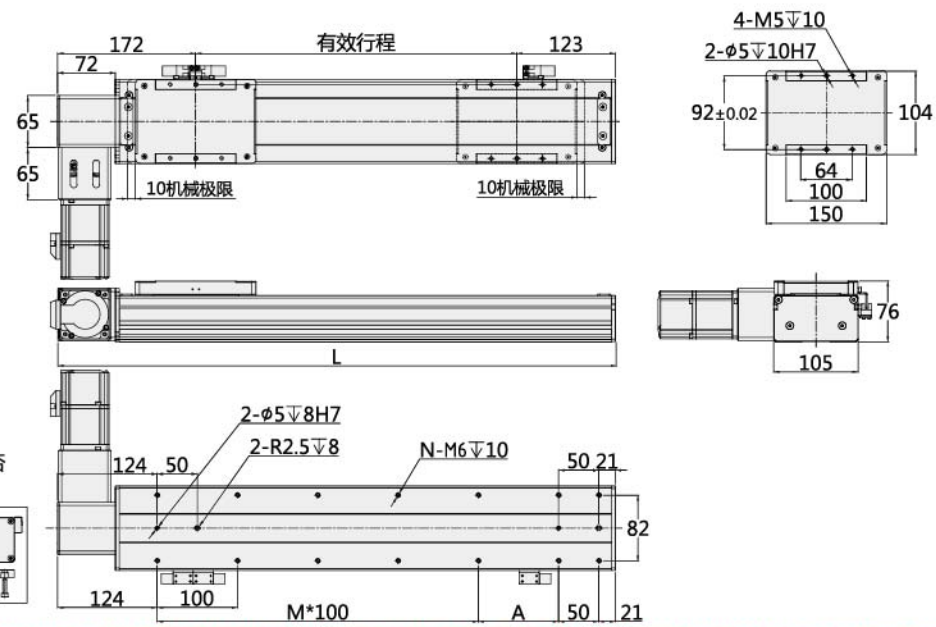

安装方式：
安装螺丝从下往上安装
*注意锁紧螺丝装入滑台
的长度不得超过11mm,否则
会与内部干涉。

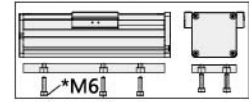

有效行程	50	100	150	200	250	300	350	400	450	500	550	600	650	700	750	800	850	900	950	1000	1050	1100	1150	1200	1250	1300
L	345	395	445	495	545	595	645	695	745	795	845	895	945	995	1045	1095	1145	1195	1245	1295	1345	1395	1445	1495	1545	1595
A	50	100	50	100	50	100	50	100	50	100	50	100	50	100	50	100	50	100	50	100	50	100	50	100	50	100
M	1	1	2	2	3	3	4	4	5	5	6	6	7	7	8	8	9	9	10	10	11	11	12	12	13	13
N	8	8	10	10	12	12	14	14	16	16	18	18	20	20	22	22	24	24	26	26	28	28	30	30	32	32
KG	6.4	6.8	7.2	7.7	8.1	8.5	9.0	9.4	9.8	10.2	10.7	11.1	11.5	12.0	12.4	12.8	13.3	13.7	14.1	14.5	15.0	15.4	15.8	16.3	16.7	17.1
有效行程	1350	1400	1450	1500	1550	1600	1650	1700	1750	1800	1850	1900	1950	2000	2050	2100	2150	2200	2250	2300	2350	2400	2450	2500	2550	2600
L	1645	1695	1745	1795	1845	1895	1945	1995	2045	2095	2145	2195	2245	2295	2345	2395	2445	2495	2545	2595	2645	2695	2745	2795	2845	2895
A	50	100	50	100	50	100	50	100	50	100	50	100	50	100	50	100	50	100	50	100	50	100	50	100	50	100
M	14	14	15	15	16	16	17	17	18	18	19	19	20	20	21	21	22	22	23	23	24	24	25	25	26	26
N	34	34	36	36	38	38	40	40	42	42	44	44	46	46	48	48	50	50	52	52	54	54	56	56	58	58
KG	17.5	18.0	18.4	18.8	19.3	19.7	20.1	20.6	21.0	21.4	21.8	22.3	22.7	23.1	23.6	24.0	24.4	24.8	25.3	25.7	26.1	26.6	27.0	27.4	27.9	28.3

注：以上不含電機重量。Note: Not including motor weight..

馬達右折-R Motor Right Side

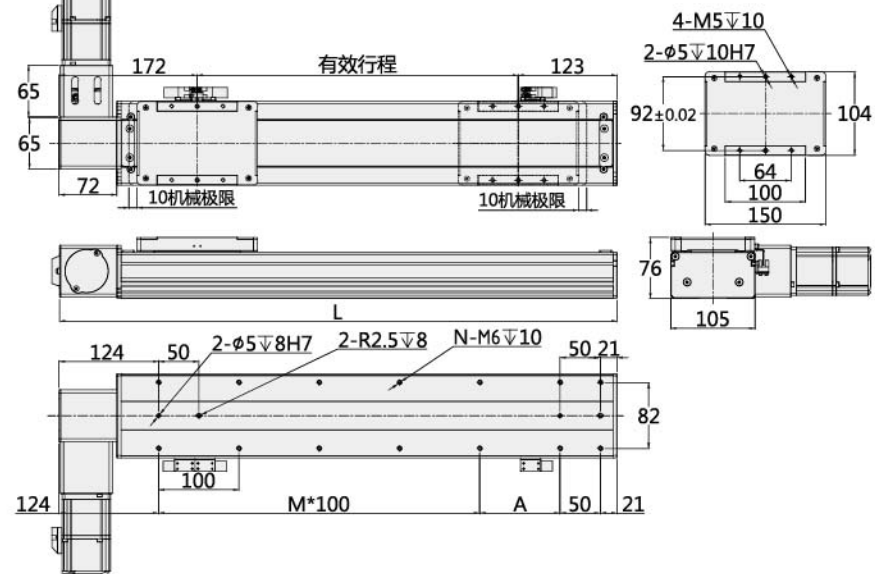

安装方式：
安装螺丝从下往上安装
*注意锁紧螺丝装入滑台
的长度不得超过11mm,否则
会与内部干涉。

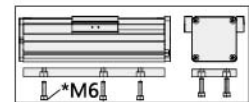

有效行程	50	100	150	200	250	300	350	400	450	500	550	600	650	700	750	800	850	900	950	1000	1050	1100	1150	1200	1250	1300
L	345	395	445	495	545	595	645	695	745	795	845	895	945	995	1045	1095	1145	1195	1245	1295	1345	1395	1445	1495	1545	1595
A	50	100	50	100	50	100	50	100	50	100	50	100	50	100	50	100	50	100	50	100	50	100	50	100	50	100
M	1	1	2	2	3	3	4	4	5	5	6	6	7	7	8	8	9	9	10	10	11	11	12	12	13	13
N	8	8	10	10	12	12	14	14	16	16	18	18	20	20	22	22	24	24	26	26	28	28	30	30	32	32
KG	6.4	6.8	7.2	7.7	8.1	8.5	9.0	9.4	9.8	10.2	10.7	11.1	11.5	12.0	12.4	12.8	13.3	13.7	14.1	14.5	15.0	15.4	15.8	16.3	16.7	17.1
有效行程	1350	1400	1450	1500	1550	1600	1650	1700	1750	1800	1850	1900	1950	2000	2050	2100	2150	2200	2250	2300	2350	2400	2450	2500	2550	2600
L	1645	1695	1745	1795	1845	1895	1945	1995	2045	2095	2145	2195	2245	2295	2345	2395	2445	2495	2545	2595	2645	2695	2745	2795	2845	2895
A	50	100	50	100	50	100	50	100	50	100	50	100	50	100	50	100	50	100	50	100	50	100	50	100	50	100
M	14	14	15	15	16	16	17	17	18	18	19	19	20	20	21	21	22	22	23	23	24	24	25	25	26	26
N	34	34	36	36	38	38	40	40	42	42	44	44	46	46	48	48	50	50	52	52	54	54	56	56	58	58
KG	17.5	18.0	18.4	18.8	19.3	19.7	20.1	20.6	21.0	21.4	21.8	22.3	22.7	23.1	23.6	24.0	24.4	24.8	25.3	25.7	26.1	26.6	27.0	27.4	27.9	28.3

注：以上不含電機重量。Note: Not including motor weight..

SEALED SYNCHRONOUS BELT SLIDE

密封式同步帶滑臺-LBC10H

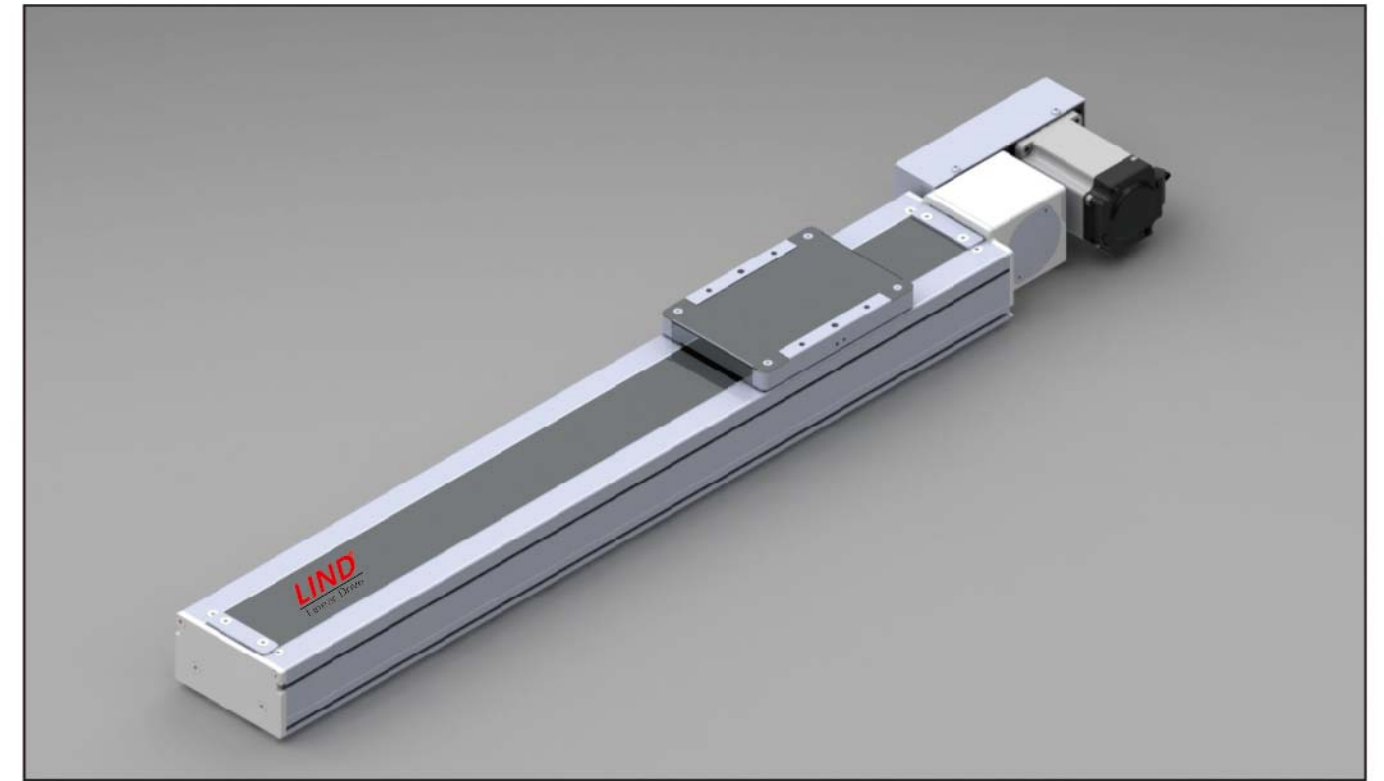

馬達安裝方式 Motor direction

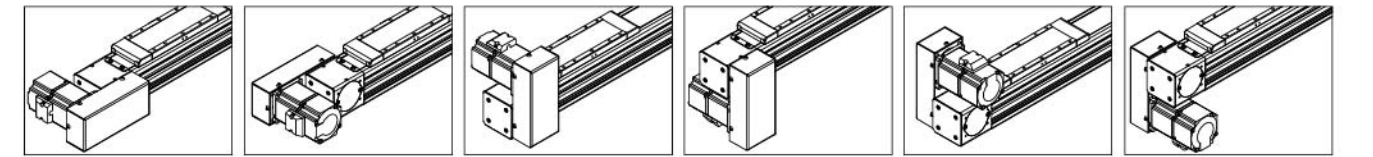

馬達左折-L Motor Left Side 馬達右折-R Motor Right Side 馬達左上折-LU Motor Left upper 馬達左下折-LD Motor Left Lower 馬達右上折-RU Motor Right upper 馬達右下折-RD Motor Right Lower

型號表示方式 Guide for Model Selection

LBC10H -L45 -S100 - L- ZP20B -T3 _ -001

本體型號 Base Style		*導程 Lead	行程mm Stroke(mm)	馬達方式 Motor way	馬達品牌 Motor Type	馬達功率 Motor power	感應開關數量 Sensor quantity	感應器類型 Sensor type	備註 Non-standard,d.c.
L45	45mm	100-2550	L 左折 R 右折 LU 左上折 LD 左下折 RU 右上折 RD 右下折	P 松下 M 三菱 T 台達 Y 安川 57 57步進電機 其他品牌電機	20 200W 40 400W	D3 3PCS D2 2PCS D1 1PCS E 无光电开关	无 NPN P PNP		
		*導程：电机旋轉一圈，滑台移动的直线距离。		Z 客户自配電機 無 我司配電機		刹車 Brakes 無 無刹車 B 帶刹車			

基本型號 Specification

馬達轉速(w) Motor Speed(rpm/mim)	500	1000	1500	2000	2500	3000
最高速度(mm/s) Maximum Payload(mm/s)	375	750	1125	1500	1875	2250
最大負載 (水平使用) Rated load	20	15	11	7	5	4
重複位置精度(mm) Repeatability(mm)	±0.04					
*導程(mm) Lead(mm)	45					
額定推力 (N) Rated thrust(N)	80					
行程範圍 Range of travel(mm)	100-2550MM/50行程遞增					
馬達功率 Motor Output(w)	200(400)					
皮帶寬度(mm) Synchro band width(mm)	20					
導軌規格(mm) Guide specification	W15XH12-2支					
感應器 sensor	EE-SX674(NPN)					

*導程:電機旋轉一圈, 滑臺移動的直線距離。

* Guide: the rotation of the motor and the straight distance of the sliding table.

*馬達加減速度時間為0.4S.
motor speed is 0.4S.

*如有特殊行程請先與技術人員聯系。

in case special stroke please contact technical services.

傳感器接綫圖 Sensor Wiring diagram

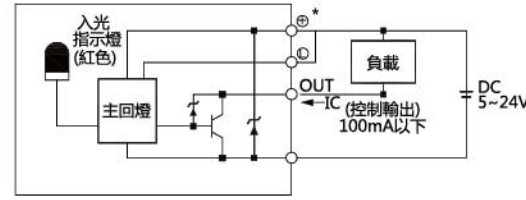

負載與速度 Speed and stroke

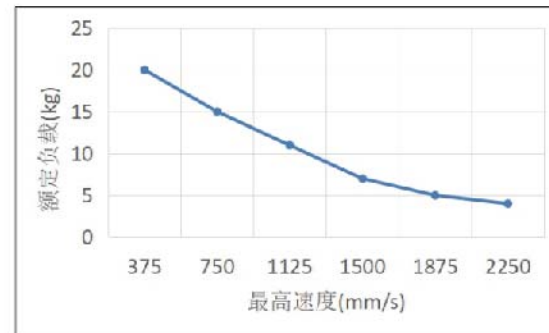

安裝示意圖 Installation Instrations&Dimentions

安裝方式一:

安裝螺絲從下往上安裝

注意鎖緊螺絲裝入滑臺的長度不得超過11mm, 否則會與內部幹啥。

Note that the length of the locking screw installed in the slide shall not exceed 10mm, otherwise it will interfere with the internal.

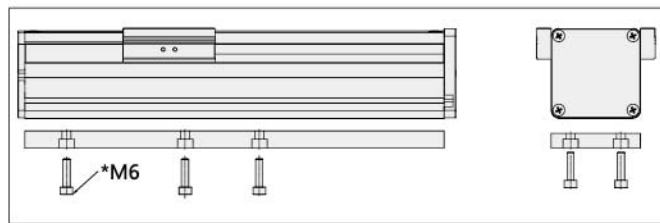

靜態力矩表 Static torque gauge

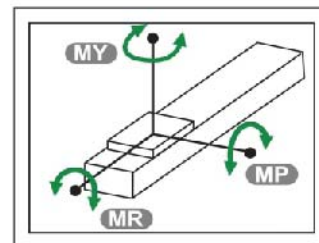

MY	160 (N.M)
MP	160 (N.M)
MR	140 (N.M)

馬達左折-L Motor Left Side

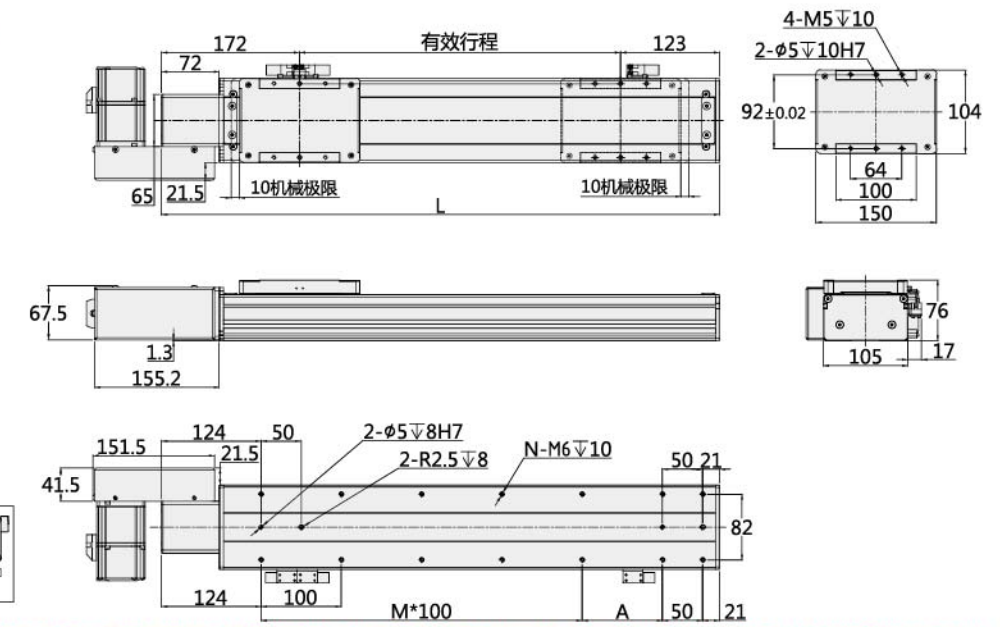

安裝方式:
安裝螺絲從下往上安裝
*注意鎖緊螺絲裝入滑臺的長度不得超過11mm, 否則會與內部干涉。

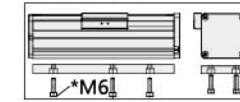

有效行程	50	100	150	200	250	300	350	400	450	500	550	600	650	700	750	800	850	900	950	1000	1050	1100	1150	1200	1250	1300
L	345	395	445	495	545	595	645	695	745	795	845	895	945	995	1045	1095	1145	1195	1245	1295	1345	1395	1445	1495	1545	1595
A	50	100	50	100	50	100	50	100	50	100	50	100	50	100	50	100	50	100	50	100	50	100	50	100	50	100
M	1	1	2	2	3	3	4	4	5	5	6	6	7	7	8	8	9	9	10	10	11	11	12	12	13	13
N	8	8	10	10	12	12	14	14	16	16	18	18	20	20	22	22	24	24	26	26	28	28	30	30	32	32
KG	6.4	6.8	7.2	7.7	8.1	8.5	9.0	9.4	9.8	10.2	10.7	11.1	11.5	12.0	12.4	12.8	13.3	13.7	14.1	14.5	15.0	15.4	15.8	16.3	16.7	17.1
有效行程	1350	1400	1450	1500	1550	1600	1650	1700	1750	1800	1850	1900	1950	2000	2050	2100	2150	2200	2250	2300	2350	2400	2450	2500	2550	2600
L	1645	1695	1745	1795	1845	1895	1945	1995	2045	2095	2145	2195	2245	2295	2345	2395	2445	2495	2545	2595	2645	2695	2745	2795	2845	2895
A	50	100	50	100	50	100	50	100	50	100	50	100	50	100	50	100	50	100	50	100	50	100	50	100	50	100
M	14	14	15	15	16	16	17	17	18	18	19	19	20	20	21	21	22	22	23	23	24	24	25	25	26	26
N	34	34	36	36	38	38	40	40	42	42	44	44	46	46	48	48	50	50	52	52	54	54	56	56	58	58
KG	17.5	18.0	18.4	18.8	19.3	19.7	20.1	20.6	21.0	21.4	21.8	22.3	22.7	23.1	23.6	24.0	24.4	24.8	25.3	25.7	26.1	26.6	27.0	27.4	27.9	28.3

注: 以上不含電機重量。Note: Not including motor weight..

馬達右折-R Motor Right Side

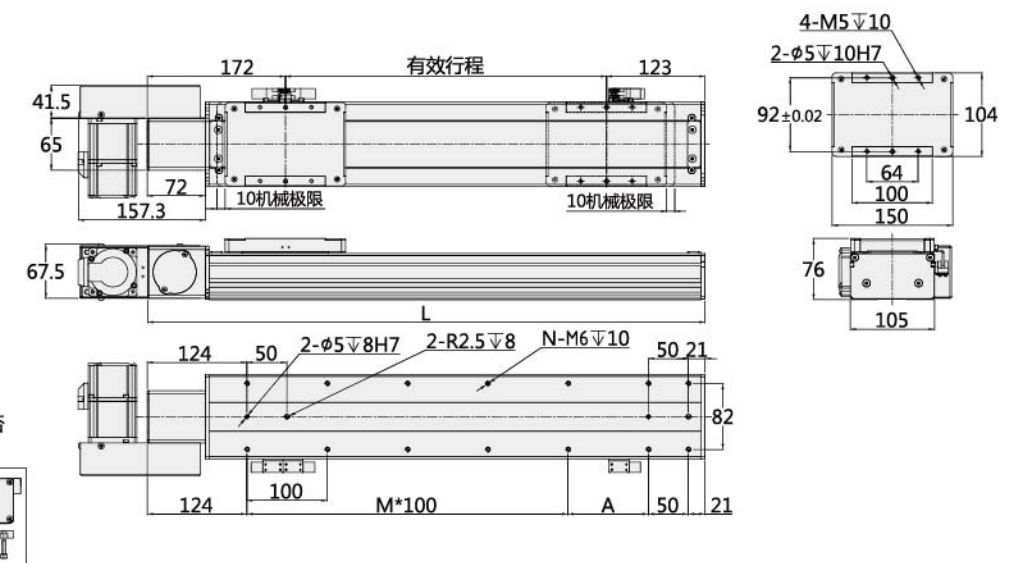

安裝方式:
安裝螺絲從下往上安裝
*注意鎖緊螺絲裝入滑臺的長度不得超過11mm, 否則會與內部干涉。

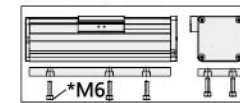

有效行程	50	100	150	200	250	300	350	400	450	500	550	600	650	700	750	800	850	900	950	1000	1050	1100	1150	1200	1250	1300
L	345	395	445	495	545	595	645	695	745	795	845	895	945	995	1045	1095	1145	1195	1245	1295	1345	1395	1445	1495	1545	1595
A	50	100	50	100	50	100	50	100	50	100	50	100	50	100	50	100	50	100	50	100	50	100	50	100	50	100
M	1	1	2	2	3	3	4	4	5	5	6	6	7	7	8	8	9	9	10	10	11	11	12	12	13	13
N	8	8	10	10	12	12	14	14	16	16	18	18	20	20	22	22	24	24	26	26	28	28	30	30	32	32
KG	6.4	6.8	7.2	7.7	8.1	8.5	9.0	9.4	9.8	10.2	10.7	11.1	11.5	12.0	12.4	12.8	13.3	13.7	14.1	14.5	15.0	15.4	15.8	16.3	16.7	17.1
有效行程	1350	1400	1450	1500	1550	1600	1650	1700	1750	1800	1850	1900	1950	2000	2050	2100	2150	2200	2250	2300	2350	2400	2450	2500	2550	2600
L	1645	1695	1745	1795	1845	1895	1945	1995	2045	2095	2145	2195	2245	2295	2345	2395	2445	2495	2545	2595	2645	2695	2745	2795	2845	2895
A	50	100	50	100	50	100	50	100	50	100	50	100	50	100	50	100	50	100	50	100	50	100	50	100	50	100
M	14	14	15	15	16	16	17	17	18	18	19	19	20	20	21	21	22	22	23	23	24	24	25	25	26	26
N	34	34	36	36	38	38	40	40	42	42	44	44	46	46	48	48	50	50	52	52	54	54	56	56	58	58
KG	17.5	18.0	18.4	18.8	19.3	19.7	20.1	20.6	21.0	21.4	21.8	22.3	22.7	23.1	23.6	24.0	24.4	24.8	25.3	25.7	26.1	26.6	27.0	27.4	27.9	28.3

注: 以上不含電機重量。Note: Not including motor weight..

馬達左上折-LU Motor Left upper

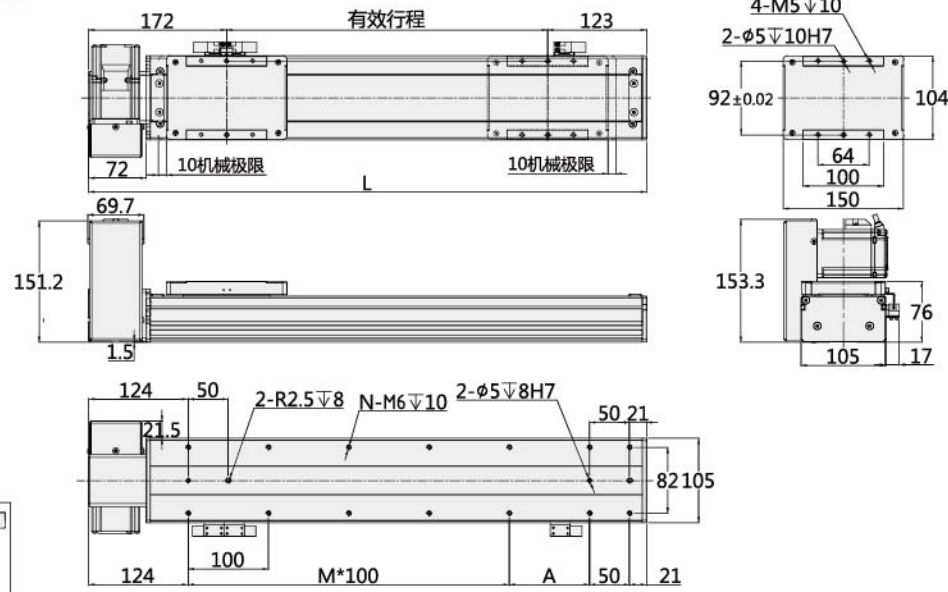

安装方式：
安装螺丝从下往上安装
*注意锁紧螺丝装入滑台
的长度不得超过11mm,否则
会与内部干涉。

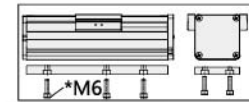

有效行程	50	100	150	200	250	300	350	400	450	500	550	600	650	700	750	800	850	900	950	1000	1050	1100	1150	1200	1250	1300
L	345	395	445	495	545	595	645	695	745	795	845	895	945	995	1045	1095	1145	1195	1245	1295	1345	1395	1445	1495	1545	1595
A	50	100	50	100	50	100	50	100	50	100	50	100	50	100	50	100	50	100	50	100	50	100	50	100	50	100
M	1	1	2	2	3	3	4	4	5	5	6	6	7	7	8	8	9	9	10	10	11	11	12	12	13	13
N	8	8	10	10	12	12	14	14	16	16	18	18	20	20	22	22	24	24	26	26	28	28	30	30	32	32
KG	6.4	6.8	7.2	7.7	8.1	8.5	9.0	9.4	9.8	10.2	10.7	11.1	11.5	12.0	12.4	12.8	13.3	13.7	14.1	14.5	15.0	15.4	15.8	16.3	16.7	17.1
有效行程	1350	1400	1450	1500	1550	1600	1650	1700	1750	1800	1850	1900	1950	2000	2050	2100	2150	2200	2250	2300	2350	2400	2450	2500	2550	2600
L	1645	1695	1745	1795	1845	1895	1945	1995	2045	2095	2145	2195	2245	2295	2345	2395	2445	2495	2545	2595	2645	2695	2745	2795	2845	2895
A	50	100	50	100	50	100	50	100	50	100	50	100	50	100	50	100	50	100	50	100	50	100	50	100	50	100
M	14	14	15	15	16	16	17	17	18	18	19	19	20	20	21	21	22	22	23	23	24	24	25	25	26	26
N	34	34	36	36	38	38	40	40	42	42	44	44	46	46	48	48	50	50	52	52	54	54	56	56	58	58
KG	17.5	18.0	18.4	18.8	19.3	19.7	20.1	20.6	21.0	21.4	21.8	22.3	22.7	23.1	23.6	24.0	24.4	24.8	25.3	25.7	26.1	26.6	27.0	27.4	27.9	28.3

注：以上不含电机重量。Note: Not including motor weight..

馬達右上折-RU Motor Left Side

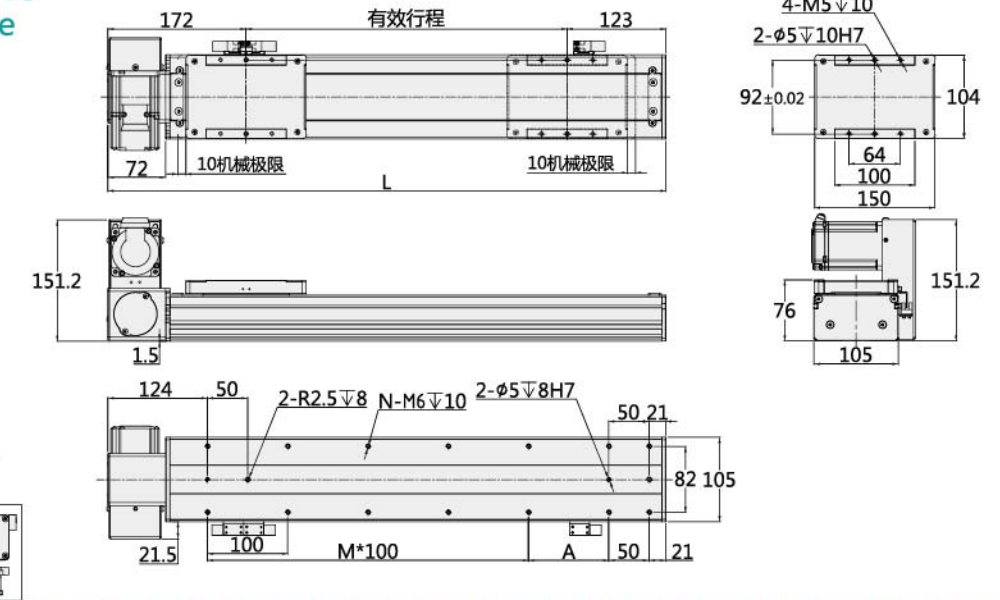

安装方式：
安装螺丝从下往上安装
*注意锁紧螺丝装入滑台
的长度不得超过11mm,否则
会与内部干涉。

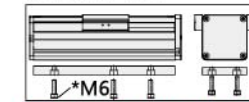

有效行程	50	100	150	200	250	300	350	400	450	500	550	600	650	700	750	800	850	900	950	1000	1050	1100	1150	1200	1250	1300
L	345	395	445	495	545	595	645	695	745	795	845	895	945	995	1045	1095	1145	1195	1245	1295	1345	1395	1445	1495	1545	1595
A	50	100	50	100	50	100	50	100	50	100	50	100	50	100	50	100	50	100	50	100	50	100	50	100	50	100
M	1	1	2	2	3	3	4	4	5	5	6	6	7	7	8	8	9	9	10	10	11	11	12	12	13	13
N	8	8	10	10	12	12	14	14	16	16	18	18	20	20	22	22	24	24	26	26	28	28	30	30	32	32
KG	6.4	6.8	7.2	7.7	8.1	8.5	9.0	9.4	9.8	10.2	10.7	11.1	11.5	12.0	12.4	12.8	13.3	13.7	14.1	14.5	15.0	15.4	15.8	16.3	16.7	17.1
有效行程	1350	1400	1450	1500	1550	1600	1650	1700	1750	1800	1850	1900	1950	2000	2050	2100	2150	2200	2250	2300	2350	2400	2450	2500	2550	2600
L	1645	1695	1745	1795	1845	1895	1945	1995	2045	2095	2145	2195	2245	2295	2345	2395	2445	2495	2545	2595	2645	2695	2745	2795	2845	2895
A	50	100	50	100	50	100	50	100	50	100	50	100	50	100	50	100	50	100	50	100	50	100	50	100	50	100
M	14	14	15	15	16	16	17	17	18	18	19	19	20	20	21	21	22	22	23	23	24	24	25	25	26	26
N	34	34	36	36	38	38	40	40	42	42	44	44	46	46	48	48	50	50	52	52	54	54	56	56	58	58
KG	17.5	18.0	18.4	18.8	19.3	19.7	20.1	20.6	21.0	21.4	21.8	22.3	22.7	23.1	23.6	24.0	24.4	24.8	25.3	25.7	26.1	26.6	27.0	27.4	27.9	28.3

注：以上不含电机重量。Note: Not including motor weight..

馬達左下折-LD Motor Right Side

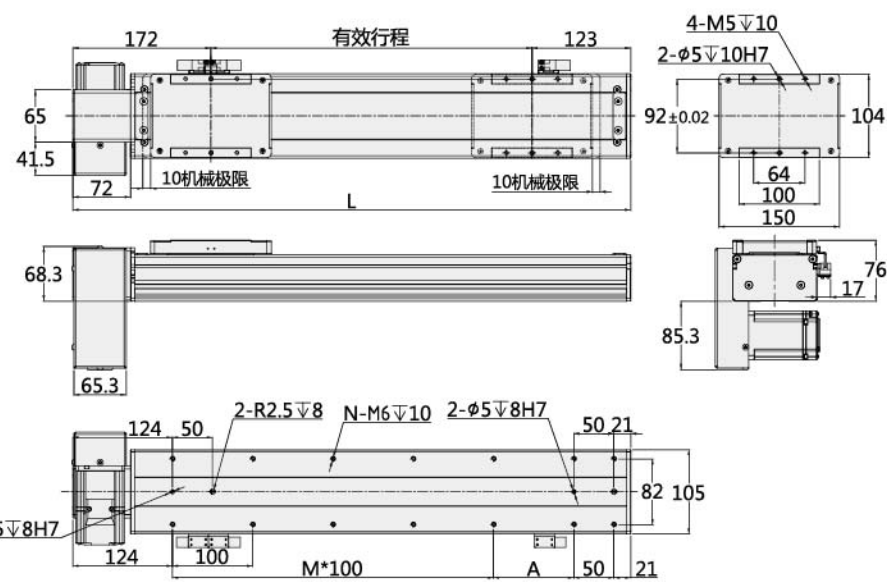

安装方式：
安装螺丝从下往上安装
*注意锁紧螺丝装入滑台
的长度不得超过11mm,否则
会与内部干涉。

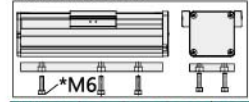

有效行程	50	100	150	200	250	300	350	400	450	500	550	600	650	700	750	800	850	900	950	1000	1050	1100	1150	1200	1250	1300
L	345	395	445	495	545	595	645	695	745	795	845	895	945	995	1045	1095	1145	1195	1245	1295	1345	1395	1445	1495	1545	1595
A	50	100	50	100	50	100	50	100	50	100	50	100	50	100	50	100	50	100	50	100	50	100	50	100	50	100
M	1	1	2	2	3	3	4	4	5	5	6	6	7	7	8	8	9	9	10	10	11	11	12	12	13	13
N	8	8	10	10	12	12	14	14	16	16	18	18	20	20	22	22	24	24	26	26	28	28	30	30	32	32
KG	6.4	6.8	7.2	7.7	8.1	8.5	9.0	9.4	9.8	10.2	10.7	11.1	11.5	12.0	12.4	12.8	13.3	13.7	14.1	14.5	15.0	15.4	15.8	16.3	16.7	17.1
有效行程	1350	1400	1450	1500	1550	1600	1650	1700	1750	1800	1850	1900	1950	2000	2050	2100	2150	2200	2250	2300	2350	2400	2450	2500	2550	2600
L	1645	1695	1745	1795	1845	1895	1945	1995	2045	2095	2145	2195	2245	2295	2345	2395	2445	2495	2545	2595	2645	2695	2745	2795	2845	2895
A	50	100	50	100	50	100	50	100	50	100	50	100	50	100	50	100	50	100	50	100	50	100	50	100	50	100
M	14	14	15	15	16	16	17	17	18	18	19	19	20	20	21	21	22	22	23	23	24	24	25	25	26	26
N	34	34	36	36	38	38	40	40	42	42	44	44	46	46	48	48	50	50	52	52	54	54	56	56	58	58
KG	17.5	18.0	18.4	18.8	19.3	19.7	20.1	20.6	21.0	21.4	21.8	22.3	22.7	23.1	23.6	24.0	24.4	24.8	25.3	25.7	26.1	26.6	27.0	27.4	27.9	28.3

注：以上不含电机重量。Note: Not including motor weight..

馬達右下折-RD Motor Right Side

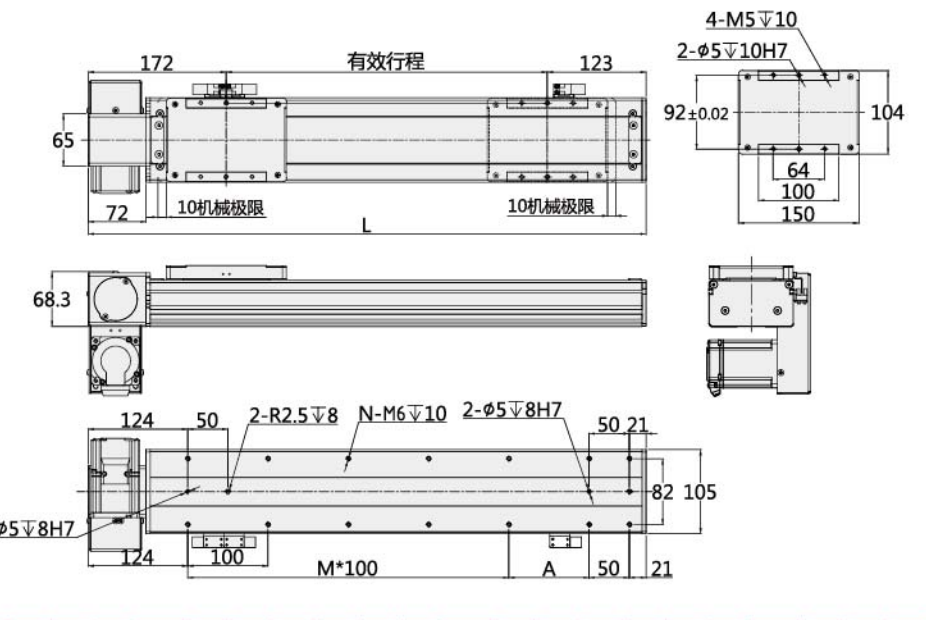

安装方式：
安装螺丝从下往上安装
*注意锁紧螺丝装入滑台
的长度不得超过11mm,否则
会与内部干涉。



有效行程	50	100	150	200	250	300	350	400	450	500	550	600	650	700	750	800	850	900	950	1000	1050	1100	1150	1200	1250	1300
L	345	395	445	495	545	595	645	695	745	795	845	895	945	995	1045	1095	1145	1195	1245	1295	1345	1395	1445	1495	1545	1595
A	50	100	50	100	50	100	50	100	50	100	50	100	50	100	50	100	50	100	50	100	50	100	50	100	50	100
M	1	1	2	2	3	3	4	4	5	5	6	6	7	7	8	8	9	9	10	10	11	11	12	12	13	13
N	8	8	10	10	12	12	14	14	16	16	18	18	20	20	22	22	24	24	26	26	28	28	30	30	32	32
KG	6.4	6.8	7.2	7.7	8.1	8.5	9.0	9.4	9.8	10.2	10.7	11.1	11.5	12.0	12.4	12.8	13.3	13.7	14.1	14.5	15.0	15.4	15.8	16.3	16.7	17.1
有效行程	1350	1400	1450	1500	1550	1600	1650	1700	1750	1800	1850	1900	1950	2000	2050	2100	2150	2200	2250	2300	2350	2400	2450	2500	2550	2600
L	1645	1695	1745	1795	1845	1895	1945	1995	2045	2095	2145	2195	2245	2295	2345	2395	2445	2495	2545	2595	2645	2695	2745	2795	2845	2895
A	50	100	50	100	50	100	50	100	50	100	50	100	50	100	50	100	50	100	50	100	50	100	50	100	50	100
M	14	14	15	15	16	16	17	17	18	18	19	19	20	20	21	21	22	22	23	23	24	24	25	25	26	26
N	34	34	36	36	38	38	40	40	42	42	44	44	46	46	48	48	50	50	52	52	54	54	56	56	58	58
KG	17.5	18.0	18.4	18.8	19.3	19.7	20.1	20.6	21.0	21.4	21.8	22.3	22.7	23.1	23.6	24.0	24.4	24.8	25.3	25.7	26.1	26.6	27.0	27.4	27.9	28.3

注：以上不含电机重量。Note: Not including motor weight..

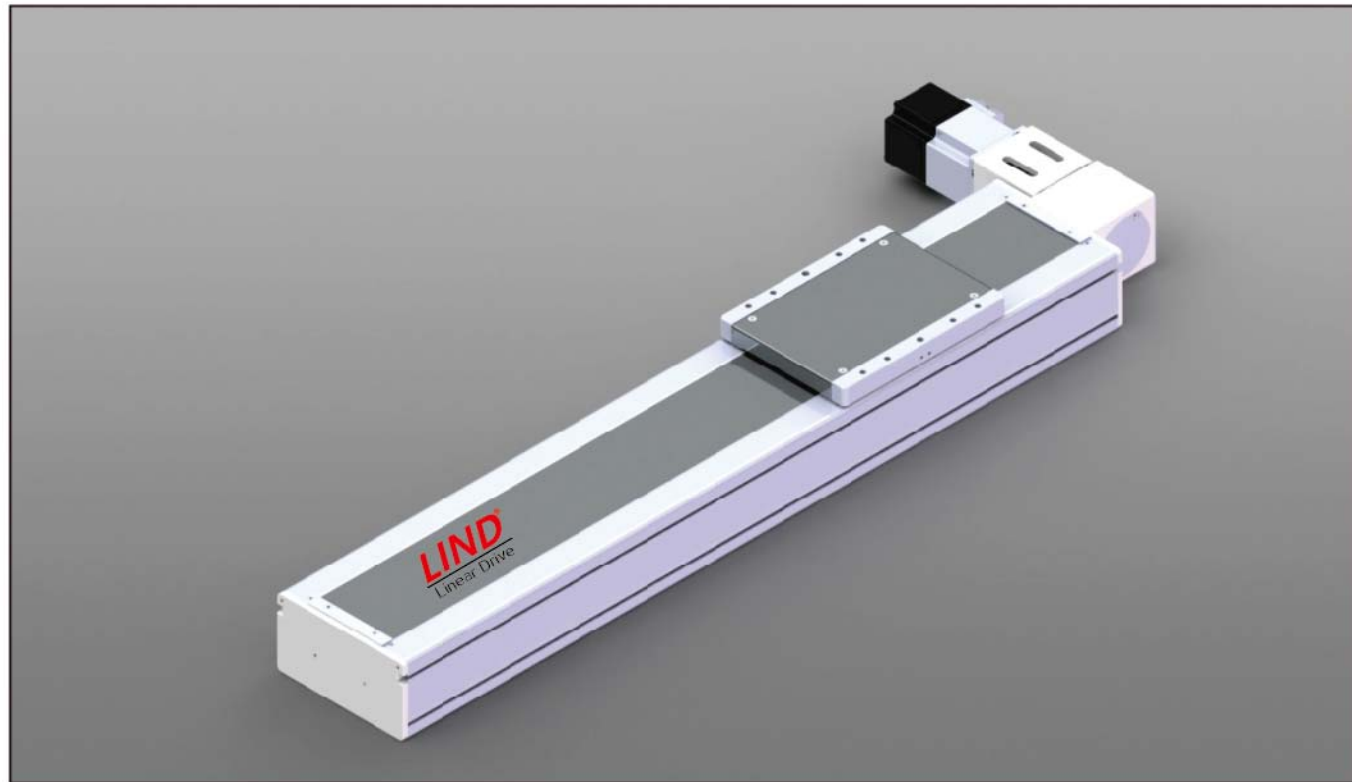

馬達安裝方式 Motor direction

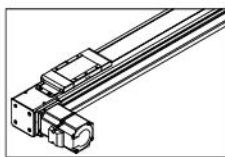

馬達左折-L
Motor Left Side

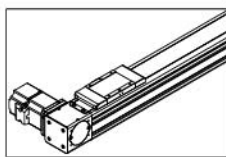

馬達右折-R
Motor Right Side

型號表示方式 Guide for Model Selection

LBC13H-L90-S100-L-ZP40B-T3 _ -001

本體型號 Base Style	*導程 Lead	行程mm Stroke(mm)	馬達方式 Motor way	馬達品牌 Motor Type	馬達功率 Motor power	感應開關數量 Sensor quantity	感應器類型 Sensor type	備註 Non-standard,d.c.
	L90 90mm	100-3100	L 左折 R 右折 Z 客戶自配電機 无 我司配電機	P 松下 M 三菱 T 台達 Y 安川 57 57步進電機 其他品牌電機	40 400W 刹車 Brakes 無 無刹車 B 帶刹車	D3 3PCS D2 2PCS D1 1PCS E 无光电开关	无 NPN P PNP	

*導程：电机旋轉一圈，滑台移動的直線距離。

基本型號 Specification

馬達轉速 Motor Speed(rpm/mim)	500 1000 1500 2000 2500 3000
最高速度(mm/s) Maximum Payload(mm/s)	750 1500 2250 3000 3750 4500
最大負載(水平使用) Rated load	17 9 6 4 2 1
重複位置精度(mm) Repeatability(mm)	±0.04
*導程(mm) Lead(mm)	90
額定推力(N) Rated thrust(N)	81
行程範圍 Range of travel(mm)	100-3100MM/50行程遞增
馬達功率 Motor Output(w)	400
皮帶寬度(mm) Synchro band width(mm)	20
導軌規格(mm) Guide specification	W15XH12-2支
連軸器 coupling	12X14
感應器 sensor	EE-SX674(NPN)

*導程：電機旋轉一圈，滑臺移動的直線距離。

* Guide: the rotation of the motor and the straight distance of the sliding table.

*馬達加減速度時間為0.4S.
motor speed is 0.4S.

*如有特殊行程請先與技術人員聯系。

in case special stroke please contact technical services.

安裝示意圖 Installation Instratons&Dimentions

安裝方式一：

安裝螺絲從下往上安裝

method 1

fix the screw from bottom to up direction

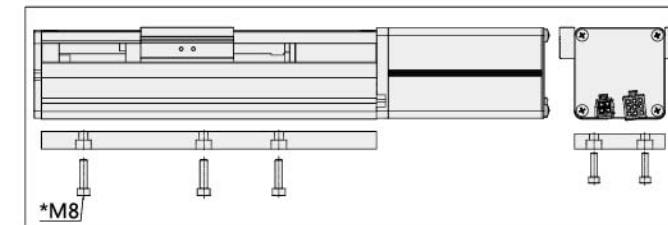

傳感器接綫圖 Sensor Wiring diagram

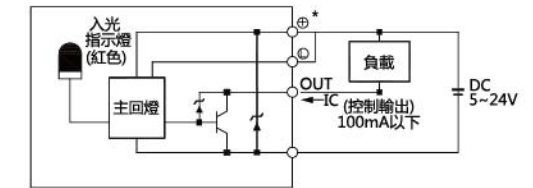

負載與速度 Speed and stroke

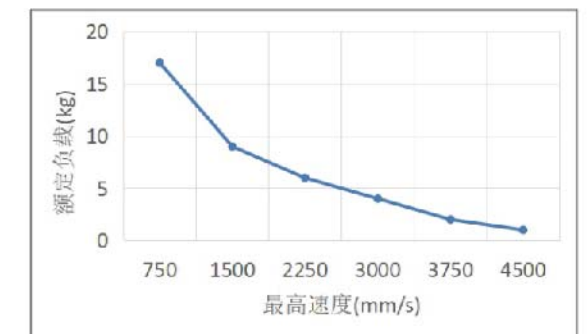

靜態力矩表 Static torque gauge

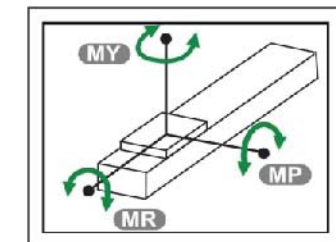

MY	550 (N.M)
MP	550 (N.M)
MR	480 (N.M)

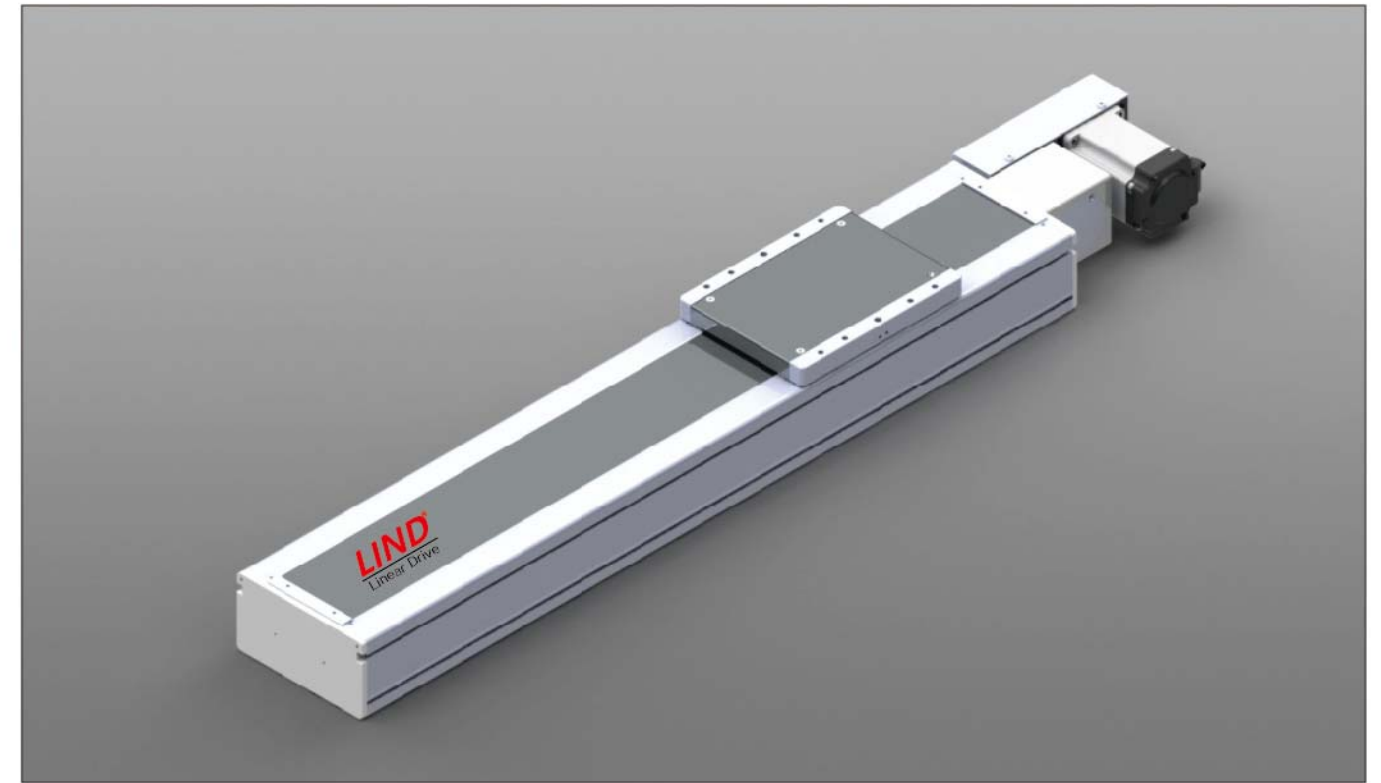

馬達左折-L
Motor Left Side

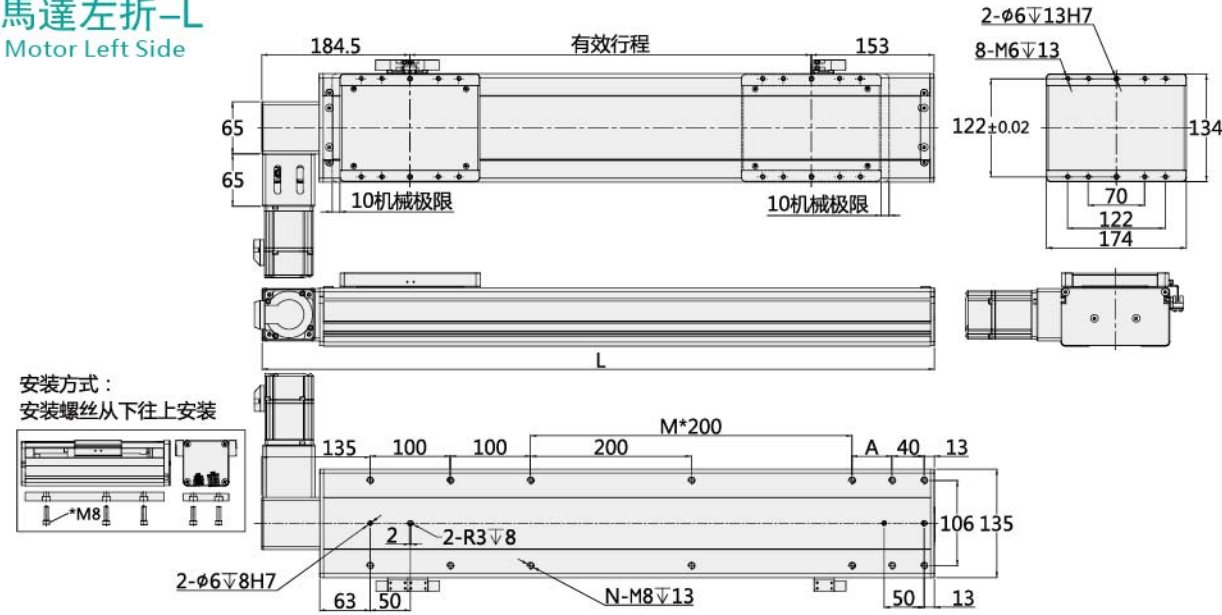

有效行程	50	100	150	200	250	300	350	400	450	500	550	600	650	700	750	800	850	900	950	1000	1050	1100	1150	1200	1250	1300	1350	1400	1450	1500	1550						
L	388	438	488	538	588	638	688	738	788	838	888	938	988	1038	1088	1138	1188	1238	1288	1338	1388	1438	1488	1538	1588	1638	1688	1738	1788	1838	1888						
A	0	0	0	0	0	0	50	100	150	200	250	300	350	400	450	500	550	600	650	700	750	800	850	900	950	1000	1050	1100	1150	1200	1250	1300	1350	1400	1450	1500	1550
M	0	0	0	0	0	0	1	1	1	1	1	2	2	2	2	3	3	3	3	4	4	4	4	5	5	5	6	6	6	6	7	7	7	7	7	7	
N	8	10	10	10	10	12	12	12	12	14	14	14	14	14	16	16	16	16	18	18	18	18	20	20	20	22	22	22	22	24	24	24	24	24	24		
KG	11.2	11.8	12.4	13.0	13.6	14.2	14.8	15.4	16.0	16.6	17.2	17.8	18.4	19.0	19.6	20.2	20.8	21.4	22.0	22.6	23.2	23.8	24.4	25.0	25.6	26.2	26.8	27.4	28.0	28.6	29.2	29.8	30.4	31.0	31.6	32.2	
有效行程	1600	1650	1700	1750	1800	1850	1900	1950	2000	2050	2100	2150	2200	2250	2300	2350	2400	2450	2500	2550	2600	2650	2700	2750	2800	2850	2900	2950	3000	3050	3100	3150	3200	3250	3300	3350	
L	1938	1988	2038	2088	2138	2188	2238	2288	2338	2388	2438	2488	2538	2588	2638	2688	2738	2788	2838	2888	2938	2988	3038	3088	3138	3188	3238	3288	3338	3388	3438	3488	3538	3588	3638	3688	
A	150	200	50	100	150	200	50	100	150	200	50	100	150	200	50	100	150	200	50	100	150	200	50	100	150	200	50	100	150	200	50	100	150	200	50	100	
M	7	7	8	8	8	8	9	9	9	10	10	10	11	11	11	11	12	12	12	12	13	13	13	13	14	14	14	14	14	14	15	15	15	15	15	15	
N	24	24	26	26	26	26	28	28	28	30	30	30	32	32	32	32	34	34	34	34	36	36	36	36	38	38	38	38	38	38	38	38	38	38	38	38	
KG	29.7	30.3	30.9	31.5	32.1	32.7	33.3	33.9	34.5	35.1	35.7	36.3	36.9	37.5	38.1	38.7	39.3	39.9	40.5	41.1	41.7	42.3	42.9	43.5	44.1	44.7	45.3	45.9	46.5	47.1	47.7	48.3	48.9	49.5	50.1		

注：以上不含電機重量。Note: Not including motor weight..

馬達右折-R
Motor Right Side

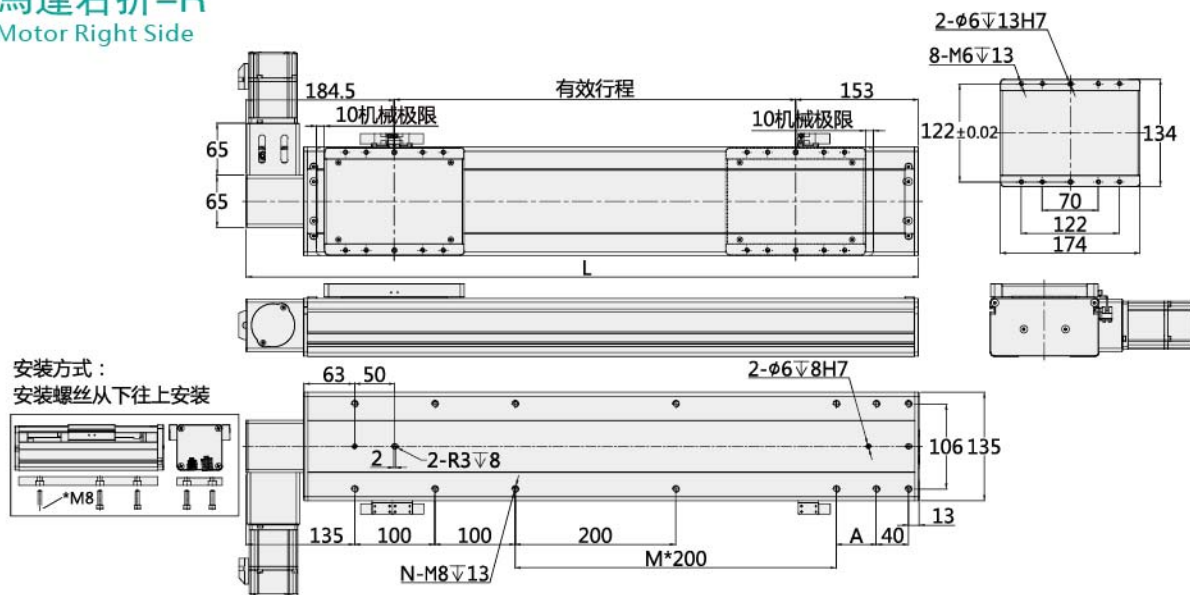

有效行程	50	100	150	200	250	300	350	400	450	500	550	600	650	700	750	800	850	900	950	1000	1050	1100	1150	1200	1250	1300	1350	1400	1450	1500	1550						
L	388	438	488	538	588	638	688	738	788	838	888	938	988	1038	1088	1138	1188	1238	1288	1338	1388	1438	1488	1538	1588	1638	1688	1738	1788	1838	1888	1938	1988	2038	2088		
A	0	0	0	0	0	0	50	100	150	200	250	300	350	400	450	500	550	600	650	700	750	800	850	900	950	1000	1050	1100	1150	1200	1250	1300	1350	1400	1450	1500	1550
M	0	0	0	0	0	0	1	1	1	1	2	2	2	2	3	3	3	3	4	4	4	4	5	5	5	6	6	6	6	7	7	7	7	7	7	7	
N	8	10	10	10	10	12	12	12	12	14	14	14	14	14	16	16	16	16	18	18	18	18	20	20	20	22	22	22	22	24	24	24	24	24	24	24	
KG	11.2	11.8	12.4	13.0	13.6	14.2	14.8	15.4	16.0	16.6	17.2	17.8	18.4	19.0	19.6	20.2	20.8	21.4	22.0	22.6	23.2	23.8	24.4	25.0	25.6	26.2	26.8	27.4	28.0	28.6	29.2	29.8	30.4	31.0	31.6	32.2	
有效行程	1600	1650	1700	1750	1800	1850	1900	1950	2000	2050	2100	2150	2200	2250	2300	2350	2400	2450	2500	2550	2600	2650	2700	2750	2800	2850	2900	2950	3000	3050	3100	3150	3200	3250	3300	3350	
L	1938	1988	2038	2088	2138	2188	2238	2288	2338	2388	2438	2488	2538	2588	2638	2688	2738	2788	2838	2888	2938	2988	3038	3088	3138	3188	3238	3288	3338	3388	3438	3488	3538	3588	3638	3688	
A	150	200	50	100	150	200	50	100	150	200	50	100	150	200	50	100	150	200	50	100	150	200	50	100	150	200	50	100	150	200	50	100	150	200	50	100	
M	7	7	8	8	8	8	9	9	9	10	10	10	11	11	11	11	12	12	12	12	13	13	13	13	14	14	14	14	14	14	15	15	15	15	15	15	
N	24	24	26	26	26	26	28	28	28	30	30	30	32	32	32	32	34	34	34	34	36	36	36	36	38	38	38	38	38	38	38	38	38	38	38	38	
KG	29.7	30.3	30.9	31.5	32.1	32.7	33.3	33.9	34.5	35.1	35.7	36.3	36.9	37.5	38.1	38.7	39.3	39.9	40.5	41.1	41.7	42.3	42.9	43.5	44.1	44.7	45.3	45.9	46.5	47.1	47.7	48.3	48.9	49.5	50.1		

注：以上不含電機重量。Note: Not including motor weight..

馬達安裝方式 Motor direction

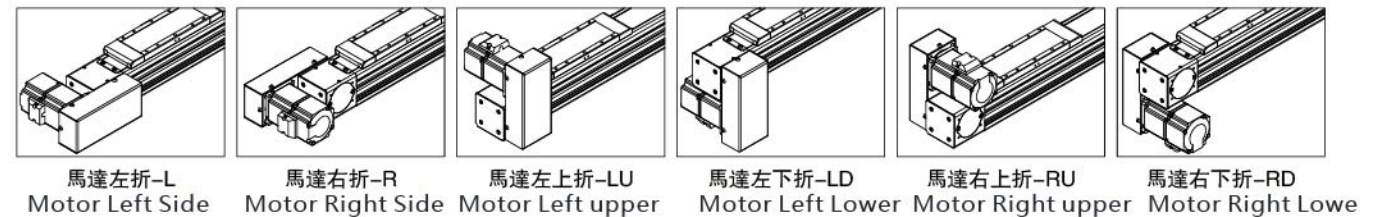

型號表示方式 Guide for Model Selection

LBC13H-L45-S100-L-ZP40B-T3 _ -001

本體型號 Base Style	*導程 Lead	行程mm Stroke(mm)	馬達方式 Motor way	馬達品牌 Motor Type	馬達功率 Motor power	感應開關數量 Sensor quantity	感應器類型 Sensor type	備註 Non-standard,d.c.
	L45 45mm	100-3100	L 左折 R 右折 LU 左上折 LD 左下折 RU 右上折 RD 右下折	P 松下 M 三菱 T 台達 Y 安川 57 57步進電機 其他品牌電機	40 400W 無 無剎車 B 帶剎車	D3 3PCS D2 2PCS D1 1PCS E 无光电开关	无 NPN P PNP	
	*導程：电机旋转一圈，滑台移动的直线距离。							
	Z 客户自配電機 无 我司配電機							

基本型號 Specification

馬達轉速(w) Motor Speed(rpm/mim)	500	1000	1500	2000	2500	3000
最高速度(mm/s) Maximum Payload(mm/s)	375	750	1125	1500	1875	2250
最大負載 (水平使用) Rated load	30	30	23	20	15	10
重複位置精度(mm) Repeatability(mm)	±0.04					
*導程(mm) Lead(mm)	45					
額定推力 (N) Rated thrust(N)	160					
行程範圍 Range of travel(mm)	100-3100MM/50行程遞增					
馬達功率 Motor Output(w)	400					
皮帶寬度(mm) Synchro band width(mm)	20					
導軌規格(mm) Guide specification	W15XH12-2支					
感應器 sensor	EE-SX674(NPN)					

*導程:電機旋轉一圈, 滑臺移動的直綫距離。

* Guide: the rotation of the motor and the straight distance of the sliding table.

*馬達加減速度時間為0.4S.
motor speed is 0.4S.

*如有特殊行程請先與技術人員聯系。

in case special stroke please contact technical services.

安裝示意圖 Installation Instrations&Dimentions

安裝方式一:

安裝螺絲從上往下安裝

method 1

fix the screw from bottom to up direction

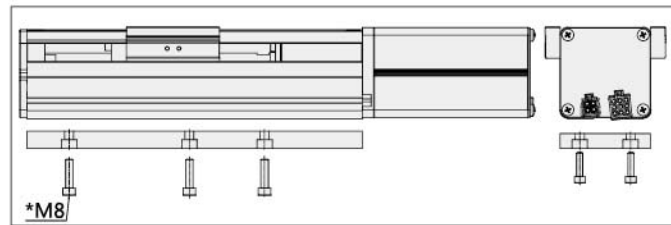

傳感器接綫圖 Sensor Wiring diagram

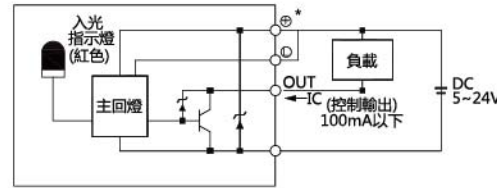

負載與速度 Speed and stroke

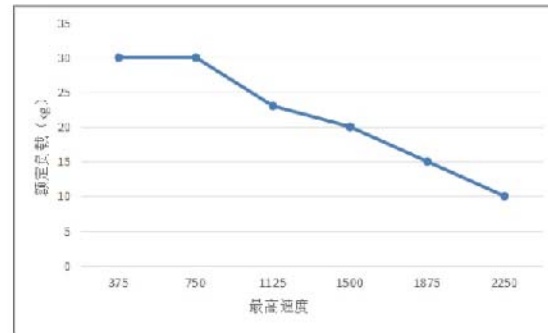

靜態力矩表 Static torque gauge

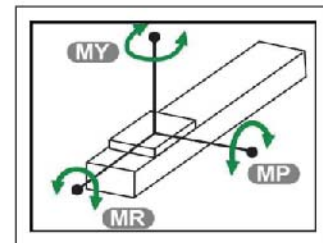

MY	550 (N.M)
MP	550 (N.M)
MR	480 (N.M)

馬達左折-L Motor Left Side

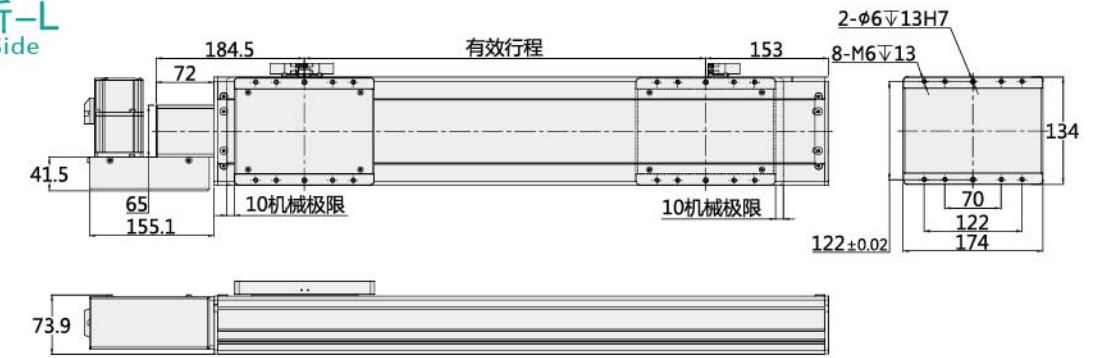

安裝方式:

安裝螺絲從下往上安裝

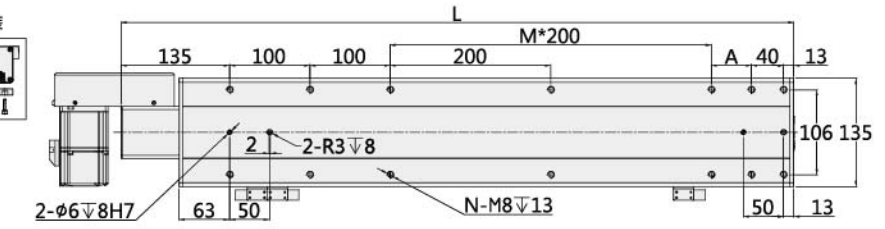
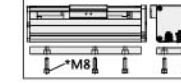

有效行程	50	100	150	200	250	300	350	400	450	500	550	600	650	700	750	800	850	900	950	1000	1050	1100	1150	1200	1250	1300	1350	1400	1450	1500	1550		
L	388	438	488	538	588	638	688	738	788	838	888	938	988	1038	1088	1138	1188	1238	1288	1338	1388	1438	1488	1538	1588	1638	1688	1738	1788	1838	1888		
A	0	0	0	0	0	0	0	0	0	0	0	0	0	0	0	0	0	0	0	0	0	0	0	0	0	0	0	0	0	0	0		
M	0	0	0	0	0	1	1	1	1	2	2	2	2	3	3	3	3	4	4	4	4	5	5	5	5	6	6	6	6	7	7		
N	8	10	10	10	10	12	12	12	12	14	14	14	14	16	16	16	16	18	18	18	18	20	20	20	20	22	22	22	22	24	24		
KG	11.2	11.8	12.4	13.0	13.6	14.2	14.8	15.4	16.0	16.6	17.2	17.8	18.4	19.0	19.6	20.2	20.8	21.4	22.0	22.6	23.2	23.8	24.4	25.0	25.6	26.2	26.8	27.4	28.0	28.6	29.2		
有效行程	1600	1650	1700	1750	1800	1850	1900	1950	2000	2050	2100	2150	2200	2250	2300	2350	2400	2450	2500	2550	2600	2650	2700	2750	2800	2850	2900	2950	3000	3050	3100		
L	1938	1988	2038	2088	2138	2188	2238	2288	2338	2388	2438	2488	2538	2588	2638	2688	2738	2788	2838	2888	2938	2988	3038	3088	3138	3188	3238	3288	3338	3388	3438		
A	150	200	50	100	150	200	50	100	150	200	50	100	150	200	50	100	150	200	50	100	150	200	50	100	150	200	50	100	150	200	50		
M	7	7	8	8	8	8	9	9	9	9	10	10	10	10	11	11	11	11	12	12	12	12	13	13	13	13	14	14	14	14	15		
N	24	24	26	26	26	26	28	28	28	28	30	30	30	30	32	32	32	32	34	34	34	34	34	34	34	36	36	36	36	38	38	38	40
KG	29.7	30.3	30.9	31.5	32.1	32.7	33.3	33.9	34.5	35.1	35.7	36.3	36.9	37.5	38.1	38.7	39.3	39.9	40.5	41.1	41.7	42.3	42.9	43.5	44.1	44.7	45.3	45.9	46.5	47.1	47.7		

注: 以上不含電機重量。Note: Not including motor weight..

馬達右折-R Motor Right Side

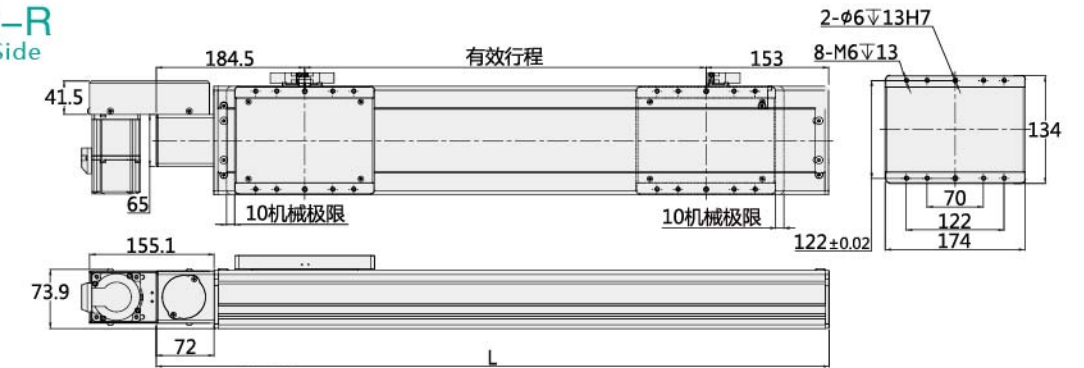

安裝方式:

安裝螺絲從下往上安裝

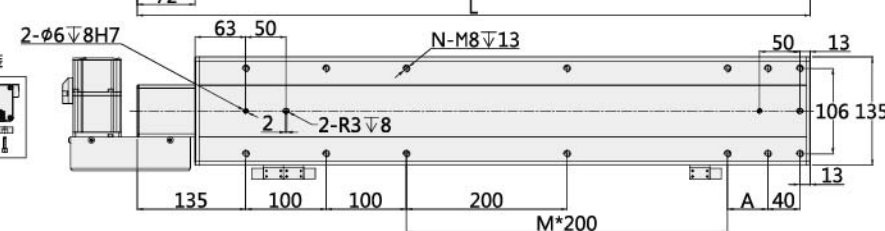
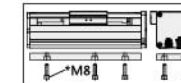

有效行程	50	100	150	200	250	300	350	400	450	500	550	600	650	700	750	800	850	900	950	1000	1050	1100	1150	1200	1250	1300	1350	1400	1450	1500	1550		
L	388	438	488	538	588	638	688	738	788	838	888	938	988	1038	1088	1138	1188	1238	1288	1338	1388	1438	1488	1538	1588	1638	1688	1738	1788	1838	1888		
A	0	0	0	0	0	0	0	0	0	0	0	0	0	0	0	0	0	0	0	0	0	0	0	0	0	0	0	0	0	0	0		
M	0	0	0	0	0	1	1	1	1	2	2	2	2	3	3	3	3	4	4	4	4	5	5	5	5	6	6	6	6	7	7		
N	8	10	10	10	10	12	12	12	12	14	14	14	14	16	16	16	16	18	18	18	18	20	20	20	20	22	22	22	22	24	24		
KG	11.2	11.8	12.4	13.0	13.6	14.2	14.8	15.4	16.0	16.6	17.2	17.8	18.4	19.0	19.6	20.2	20.8	21.4	22.0	22.6	23.2	23.8	24.4	25.0	25.6	26.2	26.8	27.4	28.0	28.6	29.2		
有效行程	1600	1650	1700	1750	1800	1850	1900	1950	2000	2050	2100	2150	2200	2250	2300	2350	2400	2450	2500	2550	2600	2650	2700	2750	2800	2850	2900	2950	3000	3050	3100		
L	1938	1988	2038	2088	2138	2188	2238	2288	2338	2388	2438	2488	2538	2588	2638	2688	2738	2788	2838	2888	2938	2988	3038	3088	3138	3188	3238	3288	3338	3388	3438		
A	150	200	50	100	150	200	50	100	150	200	50	100	150	200	50	100	150	200	50	100	150	200	50	100	150	200	50	100	150	200	50		
M	7	7	8	8	8	8	9	9	9	9	10	10	10	10	11	11	11	11	12	12	12	12	13	13	13	13	14	14	14	14	15		
N	24	24	26	26	26	26	28	28	28	28	30	30	30	30	32	32	32	32	34	34	34	34	34	34	34	36	36	36	36	38	38	38	40
KG	29.7	30.3	30.9	31.5	32.1	32.7	33.3	33.9	34.5	35.1	35.7	36.3	36.9	37.5	38.1	38.7	39.3	39.9	40.5	41.1	41.7	42.3	42.9	43.5	44.1	44.7	45.3	45.9	46.5	47.1	47.7		

注: 以上不含電機重量。Note: Not including motor weight..

馬達左上折-LU
Motor Left upper

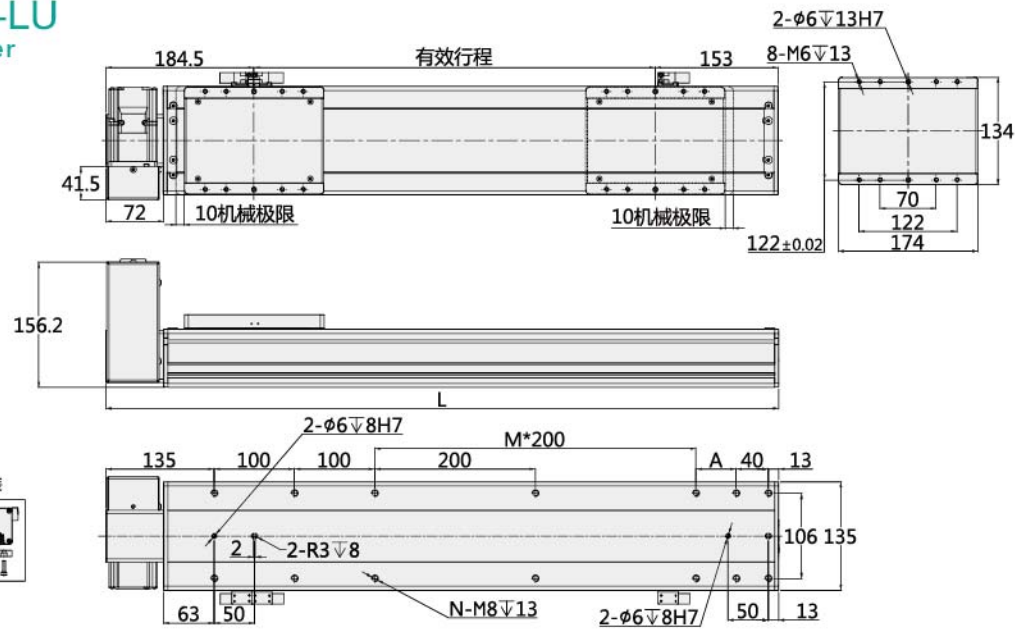

有效行程	50	100	150	200	250	300	350	400	450	500	550	600	650	700	750	800	850	900	950	1000	1050	1100	1150	1200	1250	1300	1350	1400	1450	1500	1550
L	388	438	488	538	588	638	688	738	788	838	888	938	988	1038	1088	1138	1188	1238	1288	1338	1388	1438	1488	1538	1588	1638	1688	1738	1788	1838	1888
A	0	0	0	0	0	50	100	150	200	50	100	150	200	50	100	150	200	50	100	150	200	50	100	150	200	50	100	150	200	50	100
M	0	0	0	0	0	1	1	1	1	2	2	2	2	3	3	3	4	4	4	4	5	5	5	5	6	6	6	6	7	7	
N	8	10	10	10	10	12	12	12	12	14	14	14	14	16	16	16	18	18	18	18	20	20	20	20	22	22	22	22	24	24	
KG	11.2	11.8	12.4	13.0	13.6	14.2	14.8	15.4	16.0	16.6	17.2	17.8	18.4	19.0	19.6	20.2	20.8	21.4	22.0	22.6	23.2	23.8	24.4	25.0	25.6	26.2	26.8	27.4	28.0	28.6	29.2
有效行程	1600	1650	1700	1750	1800	1850	1900	1950	2000	2050	2100	2150	2200	2250	2300	2350	2400	2450	2500	2550	2600	2650	2700	2750	2800	2850	2900	2950	3000	3050	3100
L	1938	1988	2038	2088	2138	2188	2238	2288	2338	2388	2438	2488	2538	2588	2638	2688	2738	2788	2838	2888	2938	2988	3038	3088	3138	3188	3238	3288	3338	3388	3438
A	150	200	50	100	150	200	50	100	150	200	50	100	150	200	50	100	150	200	50	100	150	200	50	100	150	200	50	100	150	200	50
M	7	7	8	8	8	8	9	9	9	9	10	10	10	10	11	11	11	11	12	12	12	12	13	13	13	13	14	14	14	15	
N	24	24	26	26	26	26	28	28	28	28	30	30	30	30	32	32	32	32	34	34	34	34	36	36	36	36	38	38	38	38	40
KG	29.7	30.3	30.9	31.5	32.1	32.7	33.3	33.9	34.5	35.1	35.7	36.3	36.9	37.5	38.1	38.7	39.3	39.9	40.5	41.1	41.7	42.3	42.9	43.5	44.1	44.7	45.3	45.9	46.5	47.1	47.7

注：以上不含電機重量。Note: Not including motor weight..

馬達右上折-RU
Motor Left Side

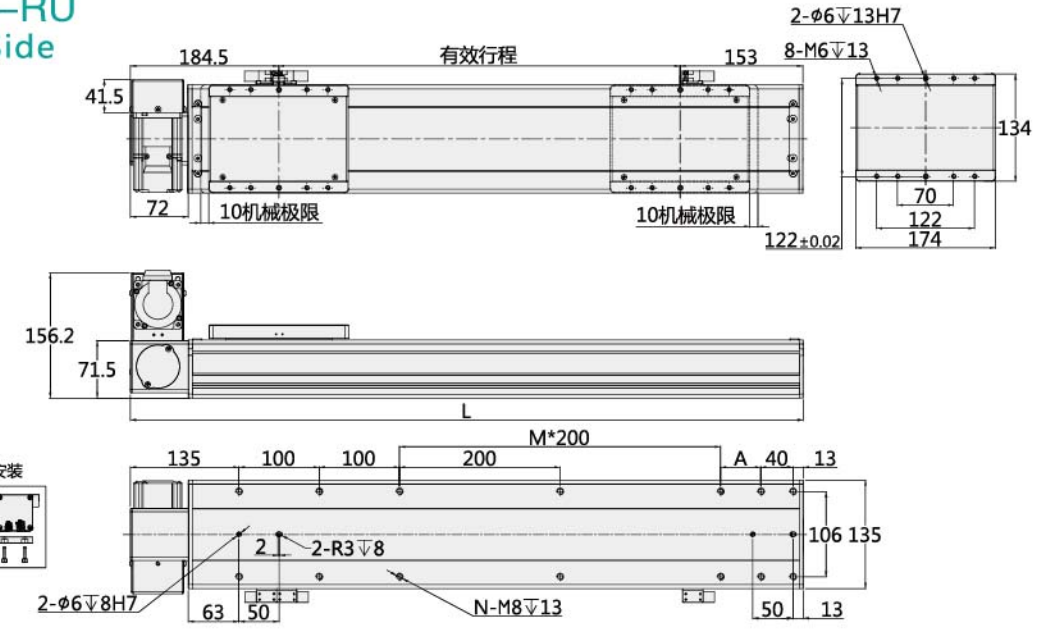

有效行程	50	100	150	200	250	300	350	400	450	500	550	600	650	700	750	800	850	900	950	1000	1050	1100	1150	1200	1250	1300	1350	1400	1450	1500	1550
L	388	438	488	538	588	638	688	738	788	838	888	938	988	1038	1088	1138	1188	1238	1288	1338	1388	1438	1488	1538	1588	1638	1688	1738	1788	1838	1888
A	0	0	0	0	0	50	100	150	200	50	100	150	200	50	100	150	200	50	100	150	200	50	100	150	200	50	100	150	200	50	100
M	0	0	0	0	0	1	1	1	1	2	2	2	2	3	3	3	4	4	4	4	5	5	5	5	6	6	6	6	7	7	
N	8	10	10	10	10	12	12	12	12	14	14	14	14	16	16	16	18	18	18	18	20	20	20	20	22	22	22	22	24	24	
KG	11.2	11.8	12.4	13.0	13.6	14.2	14.8	15.4	16.0	16.6	17.2	17.8	18.4	19.0	19.6	20.2	20.8	21.4	22.0	22.6	23.2	23.8	24.4	25.0	25.6	26.2	26.8	27.4	28.0	28.6	29.2
有效行程	1600	1650	1700	1750	1800	1850	1900	1950	2000	2050	2100	2150	2200	2250	2300	2350	2400	2450	2500	2550	2600	2650	2700	2750	2800	2850	2900	2950	3000	3050	3100
L	1938	1988	2038	2088	2138	2188	2238	2288	2338	2388	2438	2488	2538	2588	2638	2688	2738	2788	2838	2888	2938	2988	3038	3088	3138	3188	3238	3288	3338	3388	3438
A	150	200	50	100	150	200	50	100	150	200	50	100	150	200	50	100	150	200	50	100	150	200	50	100	150	200	50	100	150	200	50
M	7	7	8	8	8	8	9	9	9	9	10	10	10	10	11	11	11	11	12	12	12	12	13	13	13	13	14	14	14	15	
N	24	24	26	26	26	26	28	28	28	28	30	30	30	30	32	32	32	32	34	34	34	34	36	36	36	36	38	38	38	38	40
KG	29.7	30.3	30.9	31.5	32.1	32.7	33.3	33.9	34.5	35.1	35.7	36.3	36.9	37.5	38.1	38.7	39.3	39.9	40.5	41.1	41.7	42.3	42.9	43.5	44.1	44.7	45.3	45.9	46.5	47.1	47.7

注：以上不含電機重量。Note: Not including motor weight..

馬達左下折-LD
Motor Right Side

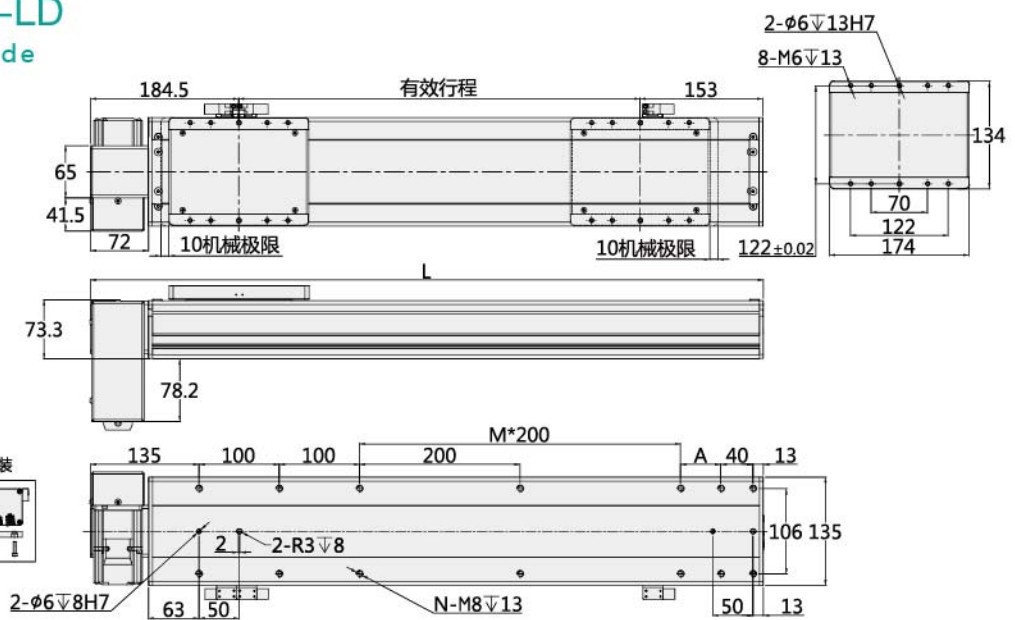

有效行程	50	100	150	200	250	300	350	400	450	500	550	600	650	700	750	800	850	900	950	1000	1050	1100	1150	1200	1250	1300	1350	1400	1450	1500	1550
L	388	438	488	538	588	638	688	738	788	838	888	938	988	1038	1088	1138	1188	1238	1288	1338	1388	1438	1488	1538	1588	1638	1688	1738	1788	1838	1888
A	0	0	0	0	0	50	100	150	200	50	100	150	200	50	100	150	200	50	100	150	200	50	100	150	200	50	100	150	200	50	100
M	0	0	0	0	0	1	1	1	1	2	2	2	2	3	3	3	4	4	4	4	5	5	5	5	6	6	6	6	7	7	
N	8	10	10	10	10	12	12	12	12	14	14	14	14	16	16	16	18	18	18	18	20	20	20	20	22	22	22	22	24	24	
KG	11.2	11.8	12.4	13.0	13.6	14.2	14.8	15.4	16.0	16.6	17.2	17.8	18.4	19.0	19.6	20.2	20.8	21.4	22.0	22.6	23.2	23.8	24.4	25.0	25.6	26.2	26.8	27.4	28.0	28.6	29.2
有效行程	1600	1650	1700	1750	1800	1850	1900	1950	2000	2050	2100	2150	2200	2250	2300	2350	2400	2450	2500	2550	2600	2650	2700	2750	2800	2850	2900	2950	3000	3050	3100
L	1938	1988	2038	2088	2138	2188	2238	2288	2338	2388	2438	2488	2538	2588	2638	2688	2738	2788	2838	2888	2938	2988	3038	3088	3138	3188	3238	3288	3338	3388	3438
A	150	200	50	100	150	200	50	100	150	200	50	100	150	200	50	100	150	200	50	100	150	200	50	100	150	200	50	100	150	200	50
M	7	7	8	8	8	8	9	9	9	9	10	10	10	10	11	11	11	11	12	12	12	12	13	13	13	13	14	14	14	15	
N	24	24	26	26	26	26	28	28	28	28	30	30	30	30	32	32	32	32	34	34	34	34	36	36	36	36	38	38	38	38	40
KG	29.7	30.3	30.9	31.5	32.1	32.7	33.3	33.9	34.5	35.1	35.7	36.3	36.9	37.5	38.1	38.7	39.3	39.9	40.5	41.1	41.7	42.3	42.9	43.5	44.1	44.7	45.3	45.9	46.5	47.1	47.7

注：以上不含電機重量。Note: Not including motor weight..

馬達右下折-RD
Motor Right Side

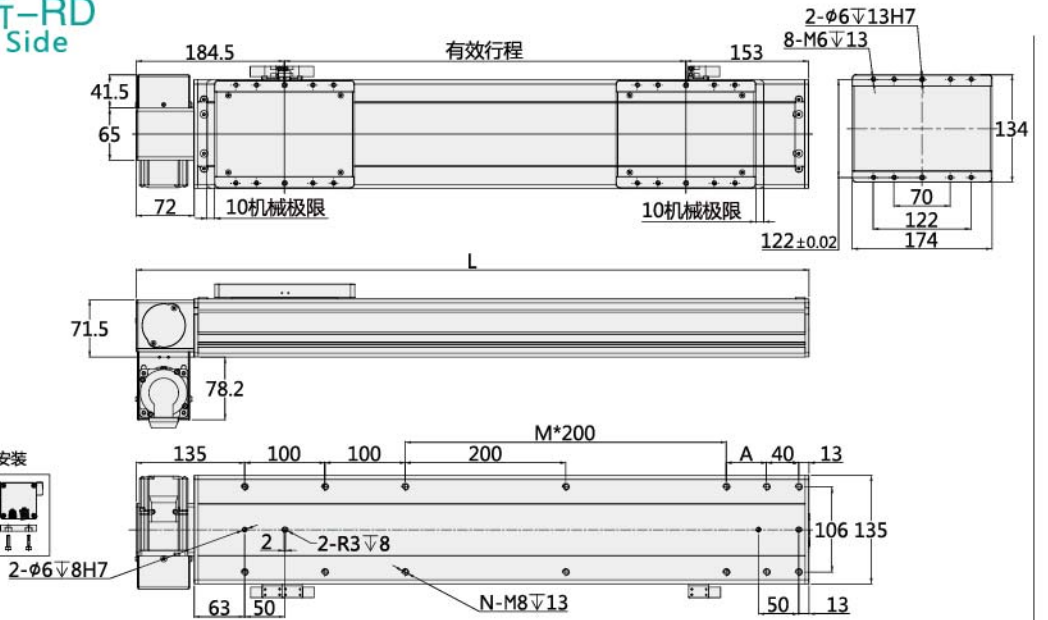

有效行程	50	100	150	200	250	300	350	400	450	500	550	600	650	700	750	800	850	900	950	1000	1050	1100	1150	1200	1250	1300	1350	1400	1450	1500	1550
L	388	438	488	538	588	638	688	738	788	838	888	938	988	1038	1088	1138	1188	1238	1288	1338	1388	1438	1488	1538	1588	1638	1688	1738	1788	1838	1888
A	0	0	0	0	0	50	100	150	200	50	100	150	200	50	100	150	200	50	100	150	200	50	100	150	200	50	100	150	200	50	100
M	0	0	0	0	0	1	1	1	1	2	2	2	2	3	3	3	4	4	4	4	5	5	5	5	6	6	6	6	7	7	
N	8	10	10	10	10	12	12	12	12	14	14	14	14	16	16	16	18	18	18	18	20	20	20	20	22	22	22	22	24	24	
KG	11.2	11.8	12.4	13.0	13.6	14.2	14.8	15.4	16.0	16.6	17.2	17.8	18.4	19.0																	

密封式同步帶滑臺-LBC17

SEALED SYNCHRONOUS BELT SLIDE

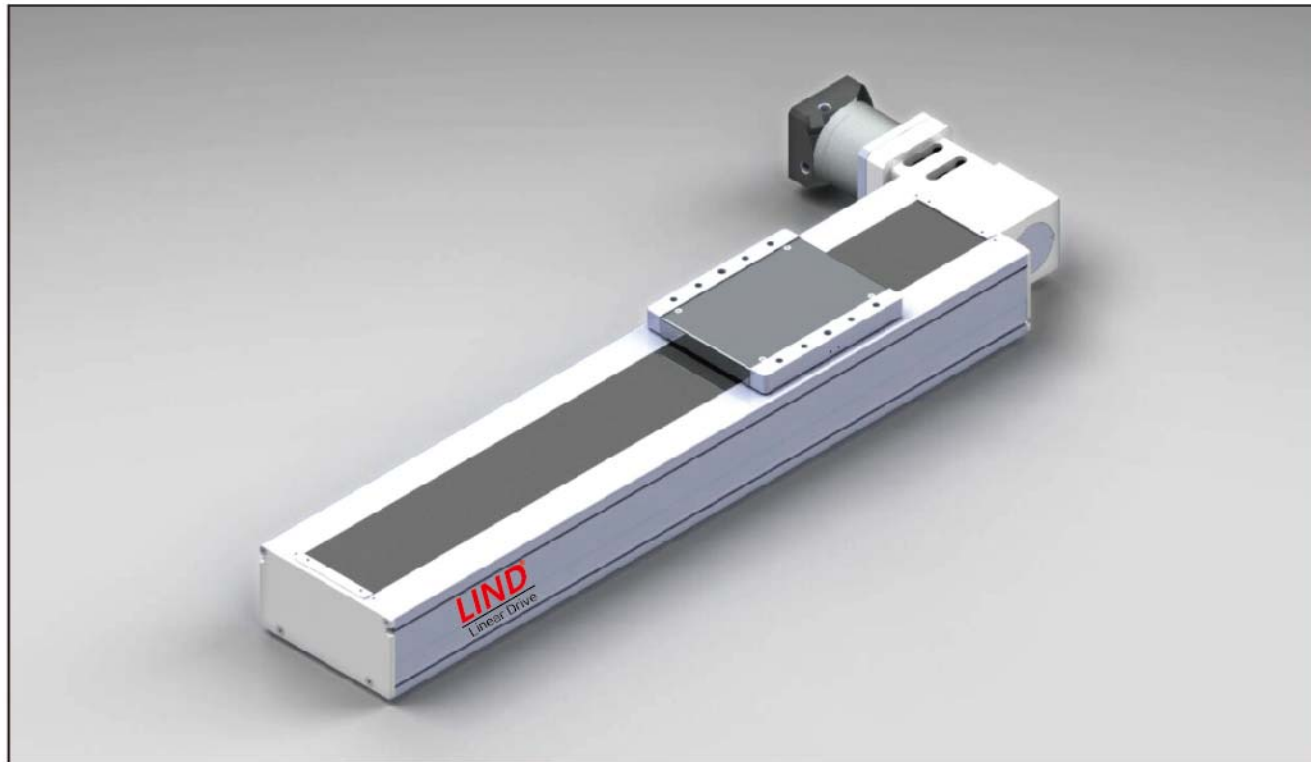

馬達安裝方式 Motor direction

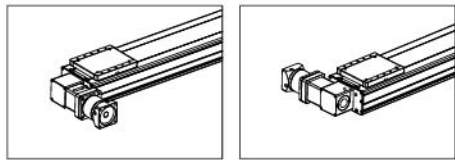

馬達左折-L Motor Left Side
馬達右折-R Motor Right Side

型號表示方式 Guide for Model Selection

LBC17 - L100 - S100 - L - ZP75B - T3 - N3 - 001

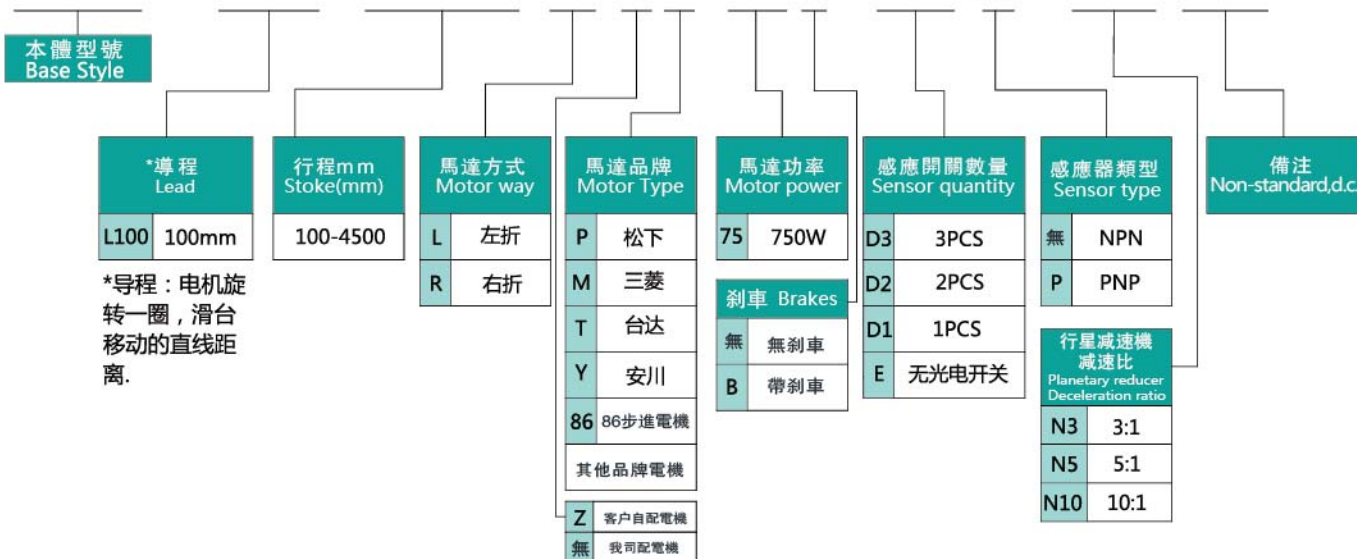

基本型號 Specification

馬達轉速(w) Motor Speed(rpm/mim)	500	1000	1500	2000	2500	3000
行星減速機(減速比) Gear reducer	1/3					
最高速度(mm/s) Maximum Payload(mm/s)	280	560	840	1120	1400	1680
最大負載(水平使用) Rated load	80	80	80	71	55	45
重複位置精度(mm) Repeatability(mm)	±0.05					
*導程(mm) Lead(mm)	100(配1/3減速機後導程為33.33)					
額定推力(N) Rated thrust(N)	400					
行程範圍 Range of travel(mm)	100-4500MM/50行程遞增					
馬達功率 Motor Output(w)	750					
皮帶寬度(mm) Synchro band width(mm)	35					
導軌規格(mm) Guide specification	W20XH15.5-2支					
感應器 sensor	EE-SX674(NPN)					

*導程:電機旋轉一圈，滑臺移動的直線距離。

* Guide: the rotation of the motor and the straight distance of the sliding table.

*馬達加減速度時間為0.4S.

motor speed is 0.4S.

*如有特殊行程請先與技術人員聯系。

in case special stroke please contact technical services.

安裝示意圖 Installation Instrations&Dimentions

安裝方式一:

安裝螺絲從上往下安裝

method 1

fix the screw from bottom to up direction

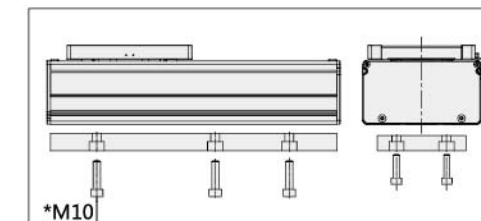

*M10

傳感器接綫圖 Sensor Wiring diagram

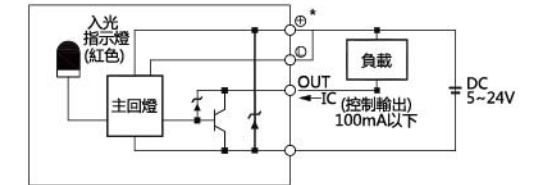

負載與速度 Speed and stroke

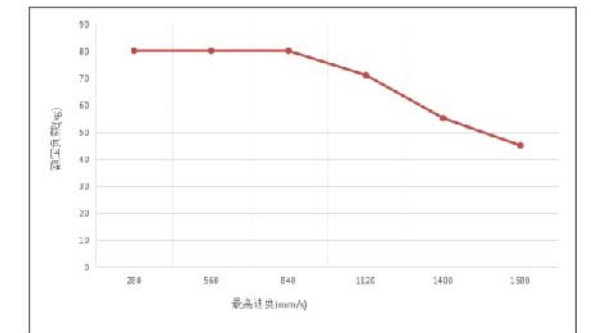

靜態力矩表 Static torque gauge

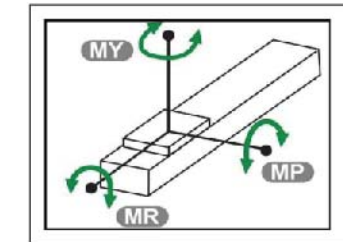

MY	1032(N.M)
MP	1034(N.M)
MR	908(N.M)

馬達左折-L Motor Left Side

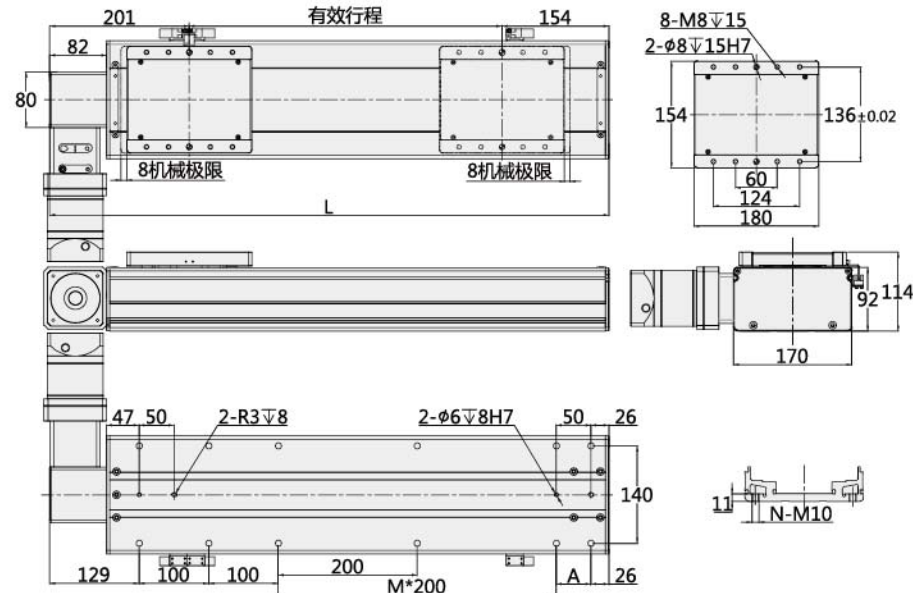

安装方式一：
安装螺丝从下往上安装

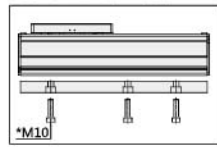

有效行程	300	350	400	450	500	550	600	650	700	750	800	850	900	950	1000	1050	1100	1150	1200	1250	1300	1350	1400	1450	1500	1550	1600	1650	
L	655	705	755	805	855	905	955	1005	1055	1105	1155	1205	1255	1305	1355	1405	1455	1505	1555	1605	1655	1705	1755	1805	1855	1905	1955	2005	
A	100	150	200	250	300	350	400	450	500	550	600	650	700	750	800	850	900	950	1000	1050	1100	1150	1200	1250	1300	1350	1400	1450	1500
M	1	1	1	2	2	2	2	3	3	3	3	4	4	4	4	5	5	5	5	6	6	6	6	7	7	7	7	8	
N	10	10	10	12	12	12	12	14	14	14	14	16	16	16	16	18	18	18	18	20	20	20	20	22	22	22	22	24	
KG	16.1	16.9	17.7	18.5	19.3	20.1	20.9	21.7	22.5	23.3	24.1	24.9	25.7	26.5	27.3	28.1	28.9	29.7	30.5	31.3	32.1	32.9	33.7	34.5	35.3	36.1	36.9	37.7	
有效行程	1700	1750	1800	1850	1900	1950	2000	2100	2200	2300	2400	2500	2600	2700	2800	2900	3000	3100	3200	3300	3400	3500	3600	3700	3800	3900	4000	4100	
L	2055	2105	2155	2205	2255	2305	2355	2455	2555	2655	2755	2855	2955	3055	3155	3255	3355	3455	3555	3655	3755	3855	3955	4055	4155	4255	4355	4455	
A	100	150	200	250	300	350	400	450	500	550	600	650	700	750	800	850	900	950	1000	1050	1100	1150	1200	1250	1300	1350	1400	1450	
M	8	8	8	9	9	9	10	10	11	11	12	12	13	13	14	14	15	15	16	16	17	17	18	18	19	19	20	20	
N	24	24	24	26	26	26	28	28	30	30	32	32	34	34	36	36	38	38	40	40	42	42	44	44	46	46	48	48	
KG	38.5	39.3	40.1	40.9	41.7	42.5	43.3	44.9	46.5	48.1	49.7	51.3	52.9	54.5	56.1	57.7	59.3	60.9	62.5	64.1	65.7	67.3	68.9	70.5	72.1	73.7	75.3	76.9	

注：以上不含電機重量。Note: Not including motor weight.

馬達右折-R Motor Right Side

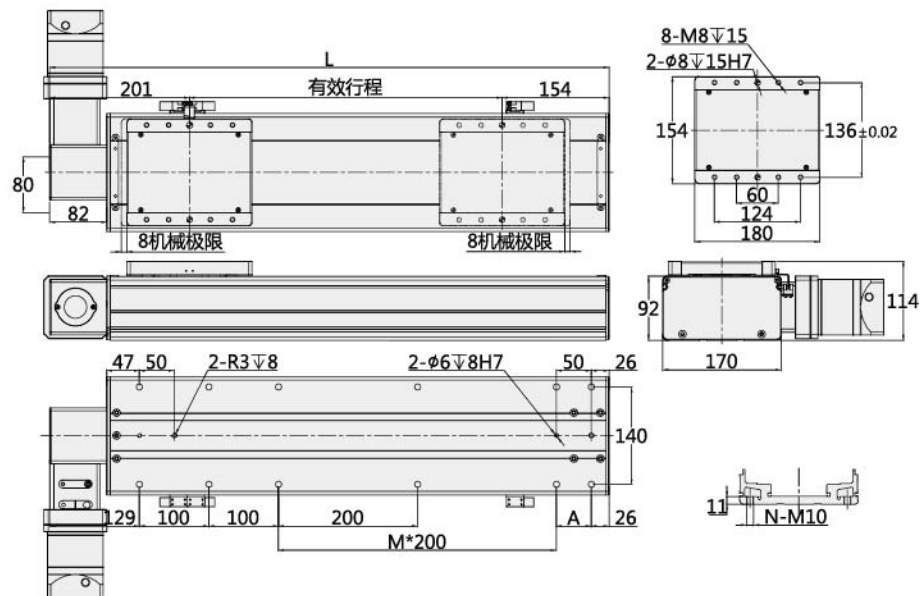

安装方式一：
安装螺丝从下往上安装

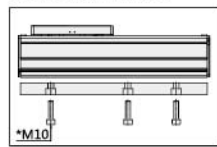

有效行程	300	350	400	450	500	550	600	650	700	750	800	850	900	950	1000	1050	1100	1150	1200	1250	1300	1350	1400	1450	1500	1550	1600	1650
L	655	705	755	805	855	905	955	1005	1055	1105	1155	1205	1255	1305	1355	1405	1455	1505	1555	1605	1655	1705	1755	1805	1855	1905	1955	2005
A	100	150	200	250	300	350	400	450	500	550	600	650	700	750	800	850	900	950	1000	1050	1100	1150	1200	1250	1300	1350	1400	1450
M	1	1	1	2	2	2	2	3	3	3	3	4	4	4	4	5	5	5	5	6	6	6	6	7	7	7	7	8
N	10	10	10	12	12	12	12	14	14	14	14	16	16	16	16	18	18	18	18	20	20	20	20	22	22	22	22	24
KG	16.1	16.9	17.7	18.5	19.3	20.1	20.9	21.7	22.5	23.3	24.1	24.9	25.7	26.5	27.3	28.1	28.9	29.7	30.5	31.3	32.1	32.9	33.7	34.5	35.3	36.1	36.9	37.7
有效行程	1700	1750	1800	1850	1900	1950	2000	2100	2200	2300	2400	2500	2600	2700	2800	2900	3000	3100	3200	3300	3400	3500	3600	3700	3800	3900	4000	4100
L	2055	2105	2155	2205	2255	2305	2355	2455	2555	2655	2755	2855	2955	3055	3155	3255	3355	3455	3555	3655	3755	3855	3955	4055	4155	4255	4355	4455
A	100	150	200	250	300	350	400	450	500	550	600	650	700	750	800	850	900	950	1000	1050	1100	1150	1200	1250	1300	1350	1400	1450
M	8	8	8	9	9	9	10	10	11	11	12	12	13	13	14	14	15	15	16	16	17	17	18	18	19	19	20	20
N	24	24	24	26	26	26	28	28	30	30	32	32	34	34	36	36	38	38	40	40	42	42	44	44	46	46	48	48
KG	38.5	39.3	40.1	40.9	41.7	42.5	43.3	44.9	46.5	48.1	49.7	51.3	52.9	54.5	56.1	57.7	59.3	60.9	62.5	64.1	65.7	67.3	68.9	70.5	72.1	73.7	75.3	76.9

注：以上不含電機重量。Note: Not including motor weight.

SEALED SYNCHRONOUS BELT SLIDE

密封式同步帶滑臺-LBC17H

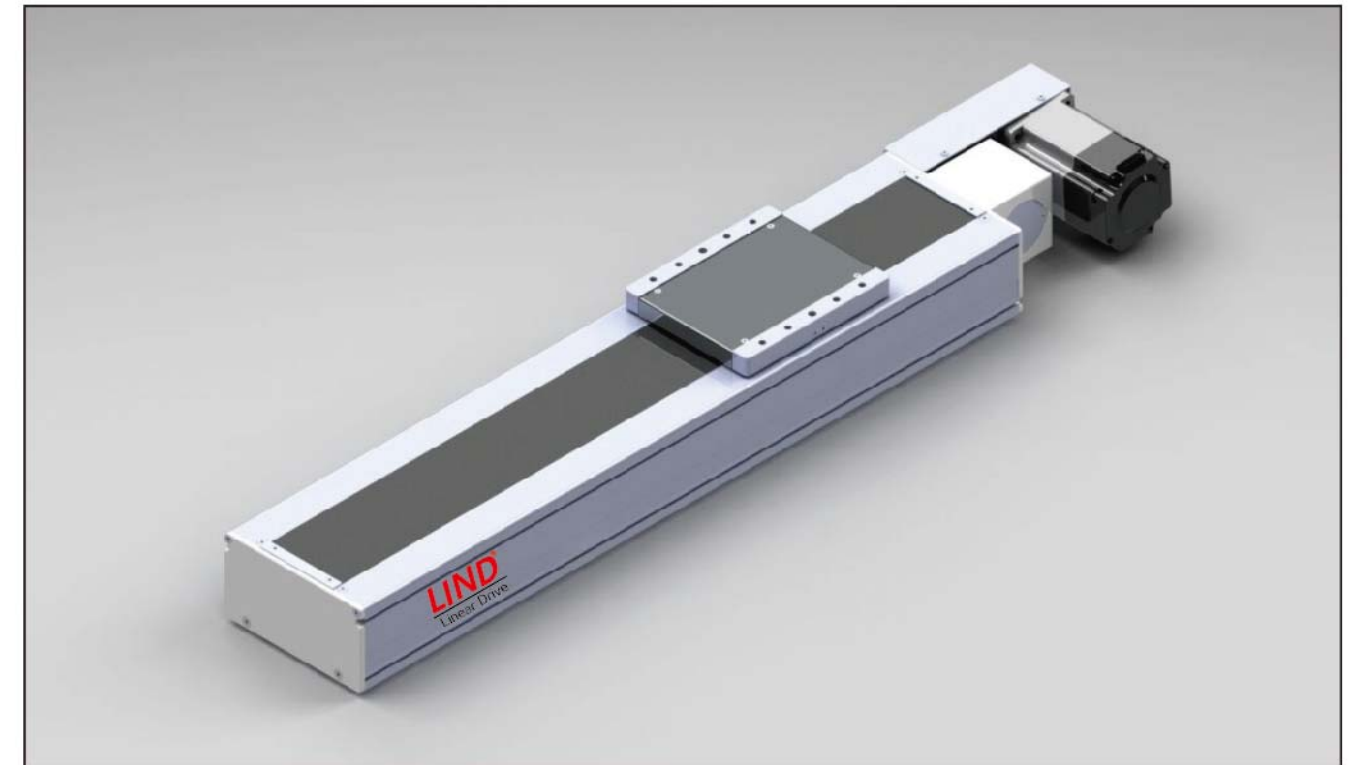

馬達安裝方式 Motor direction

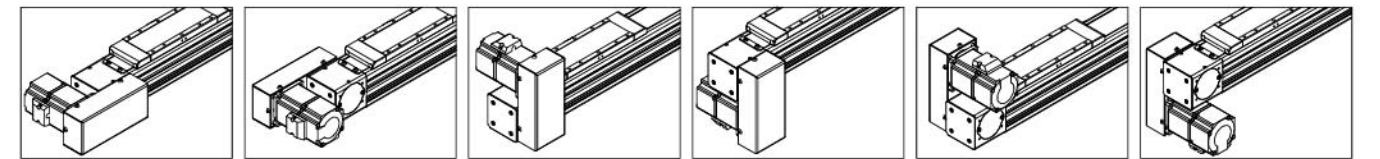

馬達左折-L Motor Left Side 馬達右折-R Motor Right Side 馬達左上折-LU Motor Left upper 馬達左下折-LD Motor Left Lower 馬達右上折-RU Motor Right upper 馬達右下折-RD Motor Right Lower

型號表示方式 Guide for Model Selection

LBC17H -L50 -S100 - L- ZP75B -T3 _ - 001

本體型號 Base Style	*導程 Lead	行程mm Stroke(mm)	馬達方式 Motor way	馬達品牌 Motor Type	馬達功率 Motor power	感應開關數量 Sensor quantity	感應器類型 Sensor type	備註 Non-standard,d.c.
	L50 50mm	100-4500	L 左折 R 右折 LU 左上折 LD 左下折 RU 右上折 RD 右下折	P 松下 M 三菱 T 台達 Y 安川 86 86步進電機 其他品牌電機	75 750W 剎車 Brakes 無 無剎車 B 帶剎車	D3 3PCS D2 2PCS D1 1PCS E 无光电开关	无 NPN P PNP	
	*導程：电机旋转一圈，滑台移动的直线距离。							
Z 客户自配電機								
無 我可配電機								

基本型號 Specification

馬達轉速(w) Motor Speed(rpm/mim)	500	1000	1500	2000	2500	3000
最高速度(mm/s) Maximum Payload(mm/s)	416	833	1250	1600	2100	2500
最大負載 (水平使用) Rated load	60	60	45	33	25	21
重複位置精度(mm) Repeatability(mm)	±0.04					
*導程(mm) Lead(mm)	50					
額定推力 (N) Rated thrust(N)	300					
行程範圍 Range of travel(mm)	100-4500MM/50行程遞增					
馬達功率 Motor Output(w)	750					
皮帶寬度(mm) Synchro band width(mm)	35					
導軌規格(mm) Guide specification	W20XH15.5-2支					
感應器 sensor	EE-SX674(NPN)					

*導程:電機旋轉一圈, 滑臺移動的直線距離.

* Guide: the rotation of the motor and the straight distance of the sliding table.

*馬達加減速度時間為0.4S.
motor speed is 0.4S.

*如有特殊行程請先與技術人員聯系.
in case special stroke please contact technical services.

安裝示意圖 Installation Instratons&Dimentions

安裝方式一:
安裝螺絲從上往下安裝

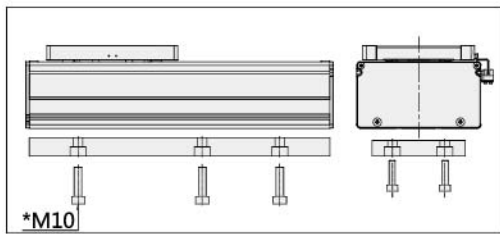

傳感器接綫圖 Specification

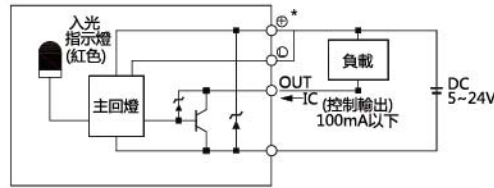

負載與速度 Speed and stroke

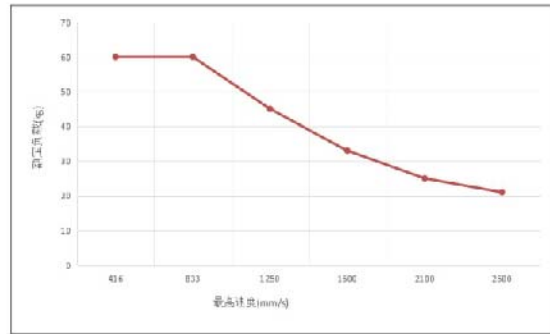

靜態力矩表 static moment

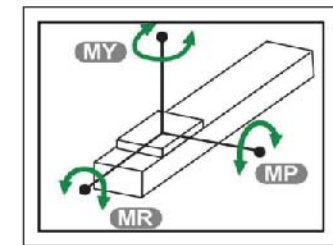

MY	1032(N.M)
MP	1034(N.M)
MR	908(N.M)

馬達左折-L Motor Left Side

安裝方式一:
安裝螺絲從下往上安裝

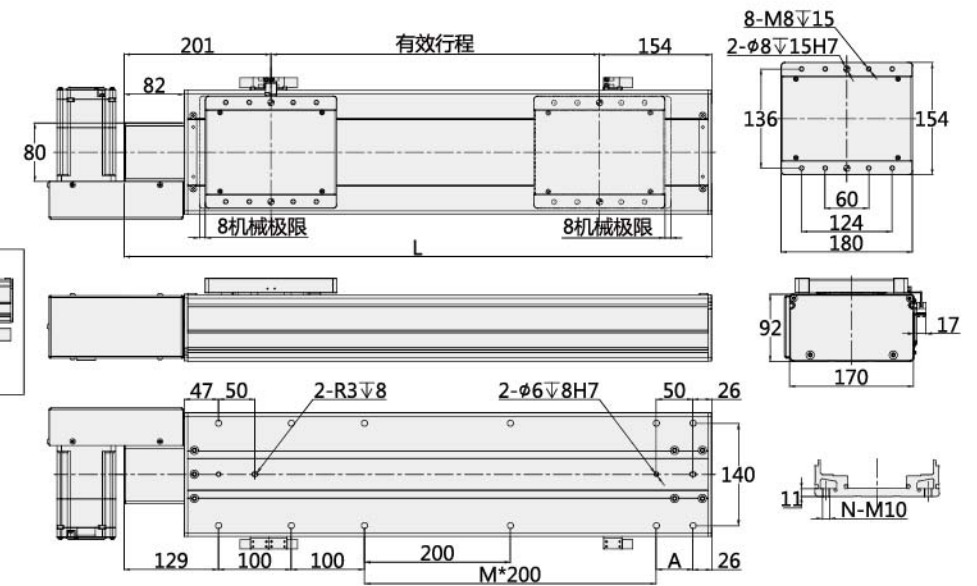
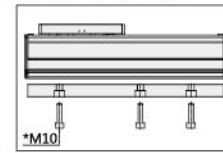

有效行程	300	350	400	450	500	550	600	650	700	750	800	850	900	950	1000	1050	1100	1150	1200	1250	1300	1350	1400	1450	1500	1550	1600	1650
L	655	705	755	805	855	905	955	1005	1055	1105	1155	1205	1255	1305	1355	1405	1455	1505	1555	1605	1655	1705	1755	1805	1855	1905	1955	2005
A	100	150	200	50	100	150	200	50	100	150	200	50	100	150	200	50	100	150	200	50	100	150	200	50	100	150	200	50
M	1	1	1	2	2	2	2	3	3	3	3	4	4	4	4	5	5	5	5	6	6	6	6	7	7	7	7	8
N	10	10	10	12	12	12	12	14	14	14	14	16	16	16	16	18	18	18	18	20	20	20	20	22	22	22	22	24
KG	16.1	16.9	17.7	18.5	19.3	20.1	20.9	21.7	22.5	23.3	24.1	24.9	25.7	26.5	27.3	28.1	28.9	29.7	30.5	31.3	32.1	32.9	33.7	34.5	35.3	36.1	36.9	37.7
有效行程	1700	1750	1800	1850	1900	1950	2000	2100	2200	2300	2400	2500	2600	2700	2800	2900	3000	3100	3200	3300	3400	3500	3600	3700	3800	3900	4000	4100
L	2055	2105	2155	2205	2255	2305	2355	2455	2555	2655	2755	2855	2955	3055	3155	3255	3355	3455	3555	3655	3755	3855	3955	4055	4155	4255	4355	4455
A	100	150	200	50	100	150	200	100	200	100	200	100	200	100	200	100	200	100	200	100	200	100	200	100	200	100	200	100
M	8	8	8	9	9	9	9	10	10	11	11	12	12	13	13	14	14	15	15	16	16	17	17	18	18	19	19	20
N	24	24	24	26	26	26	26	28	28	30	30	32	32	34	34	36	36	38	38	40	40	42	42	44	44	46	46	48
KG	38.5	39.3	40.1	40.9	41.7	42.5	43.3	44.9	46.5	48.1	49.7	51.3	52.9	54.5	56.1	57.7	59.3	60.9	62.5	64.1	65.7	67.3	68.9	70.5	72.1	73.7	75.3	76.9

注: 以上不含電機重量。Note: Not including motor weight..

馬達右折-R Motor Right Side

安裝方式一:
安裝螺絲從下往上安裝

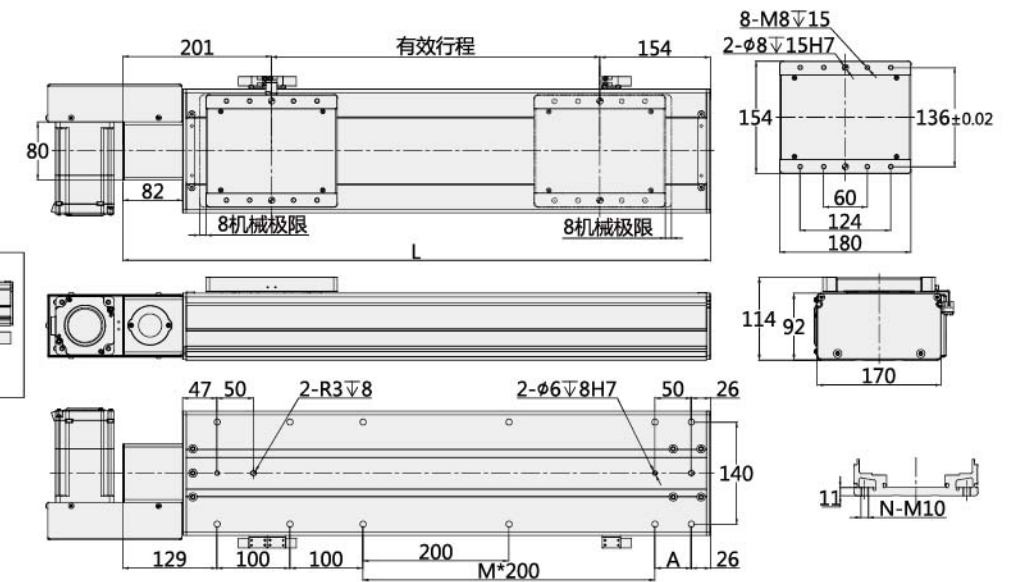
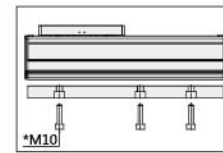

有效行程	300	350	400	450	500	550	600	650	700	750	800	850	900	950	1000	1050	1100	1150	1200	1250	1300	1350	1400	1450	1500	1550	1600	1650
L	655	705	755	805	855	905	955	1005	1055	1105	1155	1205	1255	1305	1355	1405	1455	1505	1555	1605	1655	1705	1755	1805	1855	1905	1955	2005
A	100	150	200	50	100	150	200	50	100	150	200	50	100	150	200	50	100	150	200	50	100	150	200	50	100	150	200	50
M	1	1	1	2	2	2	2	3	3	3	3	4	4	4	4	5	5	5	5	6	6	6	6	7	7	7	7	8
N	10	10	10	12	12	12	12	14	14	14	14	16	16	16	16	18	18	18	18	20	20	20	20	22	22	22	22	24
KG	16.1	16.9	17.7	18.5	19.3	20.1	20.9	21.7	22.5	23.3	24.1	24.9	25.7	26.5	27.3	28.1	28.9	29.7	30.5	31.3	32.1	32.9	33.7	34.5	35.3	36.1	36.9	37.7
有效行程	1700	1750	1800	1850	1900	1950	2000	2100	2200	2300	2400	2500	2600	2700	2800	2900	3000	3100	3200	3300	3400	3500	3600	3700	3800	3900	4000	4100
L	2055	2105	2155	2205	2255	2305	2355	2455	2555	2655	2755	2855	2955	3055	3155	3255	3355	3455	3555	3655	3755	3855	3955	4055	4155	4255	4355	4455
A	100	150	200	50	100	150	200	100	200	100	200	100	200	100	200	100	200	100	200	100	200	100	200	100	200	100	200	100
M	8	8	8	9	9	9	9	10	10	11	11	12	12	13	13	14	14	15	15	16	16	17	17	18	18	19	19	20
N	24	24	24	26	26	26	26	28	28	30	30	32	32	34	34	36	36	38	38	40	40	42	42	44	44	46	46	48
KG	38.5	39.3	40.1	40.9	41.7	42.5	43.3	44.9	46.5	48.1	49.7	51.3	52.9	54.5	56.1	57.7	59.3	60.9	62.5	64.1	65.7	67.3	68.9	70.5	72.1	73.7	75.3	76.9

注: 以上不含電機重量。Note: Not including motor weight..



手輪直連外置-SL Handwheel Exposed

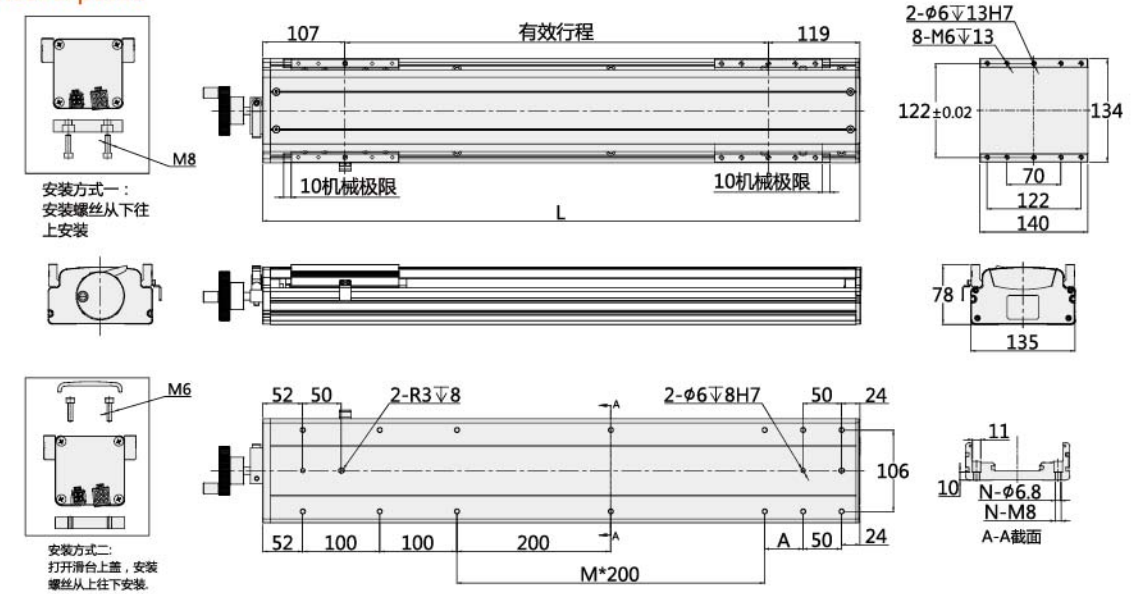

有效行程	50	100	150	200	250	300	350	400	450	500	550	600	650	700	750	800	850	900	950	1000	1050	1100
L	276	326	376	426	476	526	576	626	676	726	776	826	876	926	976	1026	1076	1126	1176	1226	1276	1326
A	0	0	0	0	0	50	100	150	200	50	100	150	200	50	100	150	200	50	100	150	200	50
M	0	0	0	0	0	1	1	1	1	2	2	2	2	3	3	3	3	4	4	4	4	5
N	8	10	10	10	10	12	12	12	12	14	14	14	14	16	16	16	16	18	18	18	18	20
KG	6.2	6.8	7.4	8	8.6	9.2	9.8	10.4	11	11.6	12.2	12.8	13.4	14	14.6	15.2	15.8	16.4	17	17.6	18.2	18.8

注：以上不含電機重量 Note: Not including motor weight.
如有特殊行程請先與技術人員聯系 in case special stroke please contact technical services.

型號表示方式 Guide for Model Selection

LES13 -L5 -S100 - SL

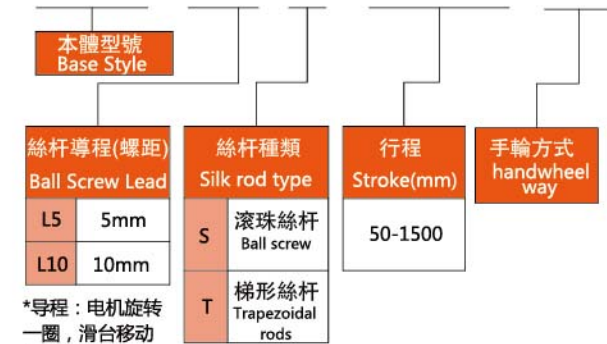

*导程：电机旋转一圈，滑台移动的直线距离。

基本型號 Specification

額定負載 (kg) Rated load	(水平使用) Horizontal (垂直使用) Vertical	110 33
行程範圍(mm) Range of travel		50-1500MM/50行程遞增
絲杆外徑(mm) Screw diameter		∅16
絲杆反向間隙 (mm) Reverse clearance of screw rod	滾珠絲杆 梯形絲杆	±0 ±0.3
導軌規格 Guide specification		W15XH12-2支

靜態力矩表 Static moment

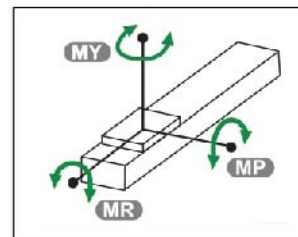

MY	551 (N.M)
MP	552 (N.M)
MR	485 (N.M)

微型絲杆滑臺-LSH20

MICRO-SCREW SLIDE

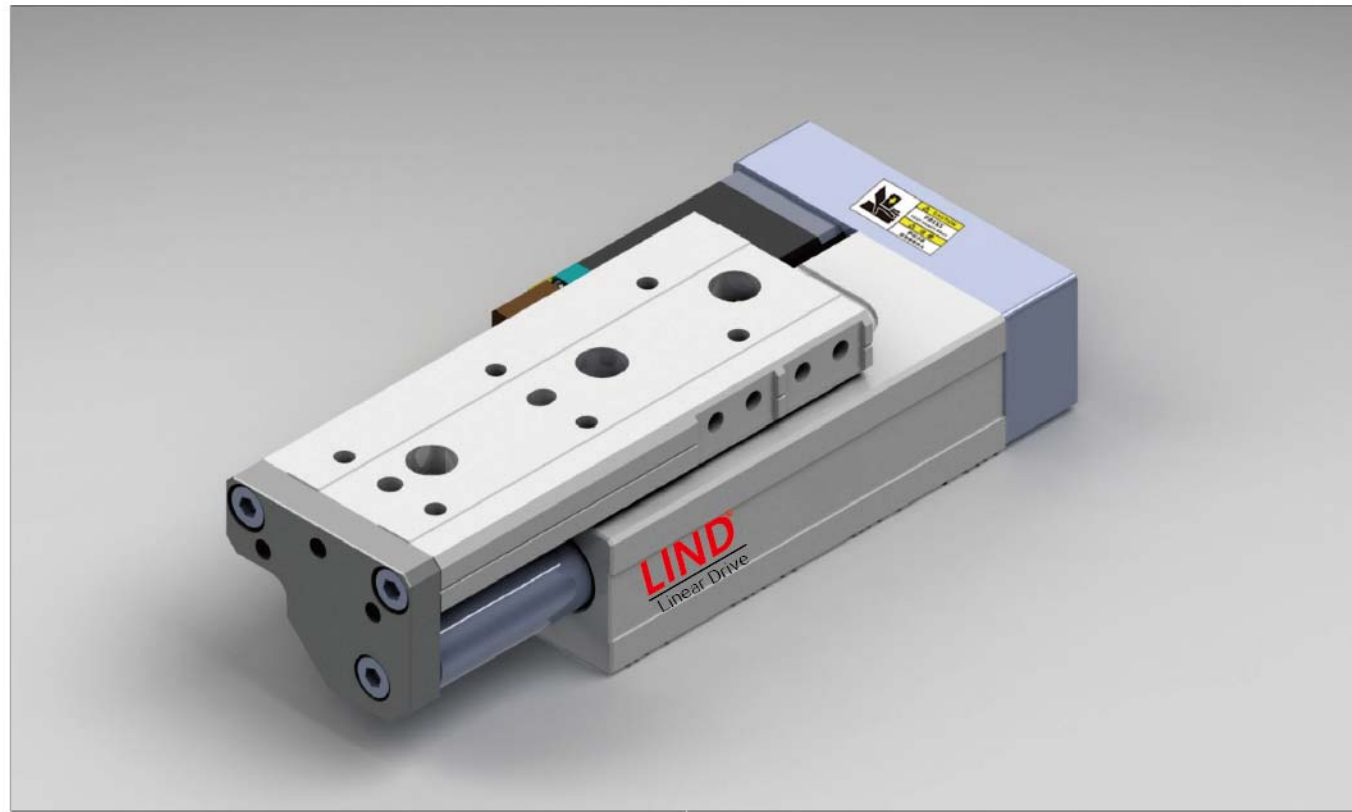

行程範圍-30MM Range of travel-30mm

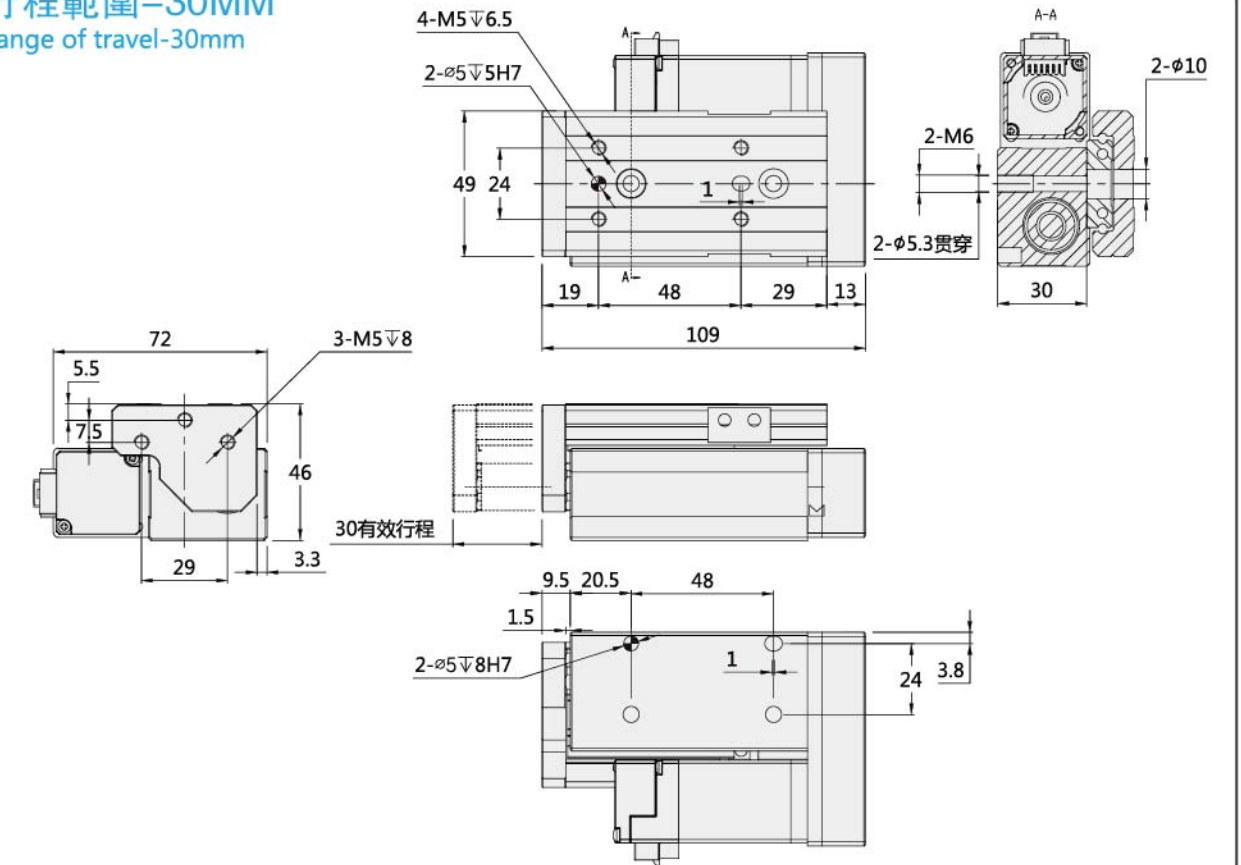

型號表示方式 Guide for Model Selection

LSH20 - L2 - S30 -

本體型號 Base Style	滾珠絲杆導程 (螺距) Ball Screw Lead	行程 Stroke(mm)	感應器類型 Sensor type
L2	2mm	30	无 NPN
L5	5mm	50	P PNP

速度與負載 Speed and load

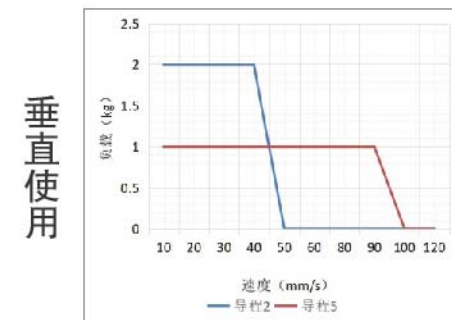
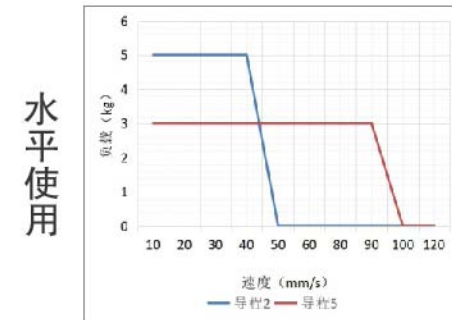

基本規格 Specification

馬達尺寸 (mm) Motor(mm)	28	
滾珠絲杆導程-螺距(mm) Belt Lead(mm)	2	5
最高速度 (mm/s) Maximum Payload(mm/s)	40	100
最大負載 Maximum load	(水平使用) Horizontal	5 3
	(垂直使用) Vertical	2 1
額定推力(N) Rated thrust	301	120
行程範圍 (mm) Range of travel	30/50	
絲杆外徑(mm) Screw diameter	ø8	
重複位置精度(mm) Repeatability	±0.02(C7)	
導軌規格 Guide specification	49MM(一體式)	

行程範圍-50MM Range of travel-50mm

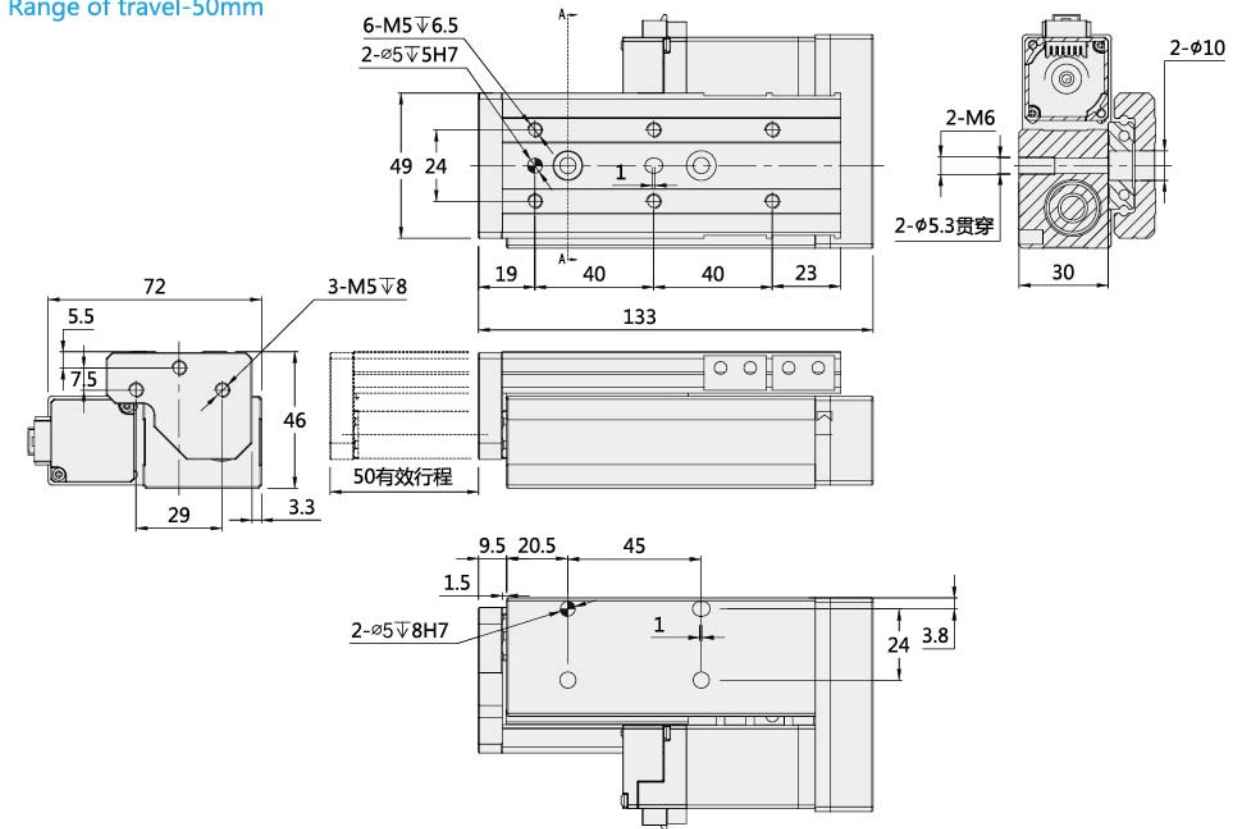

微型絲杆滑臺-LLH20

MICRO-SCREW SLIDE

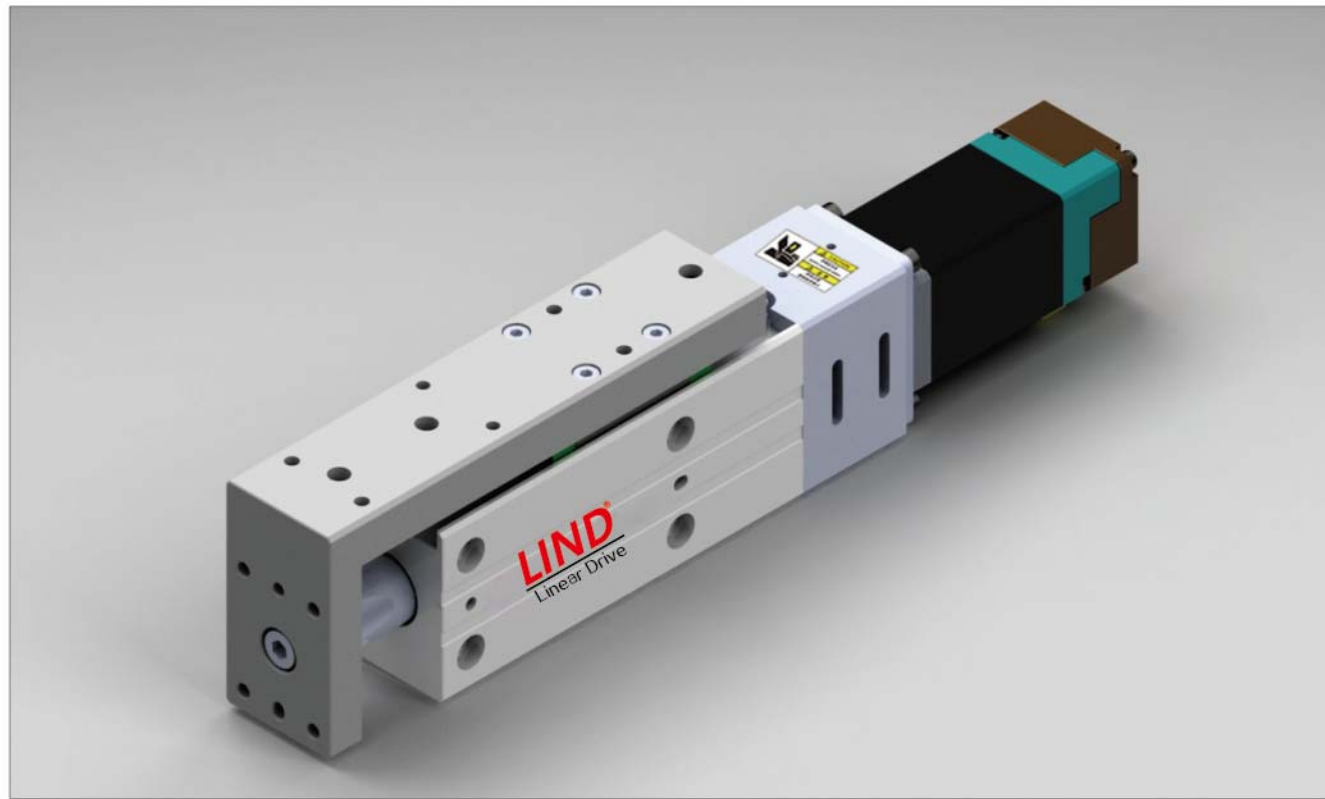

行程範圍-30MM Range of travel-30mm

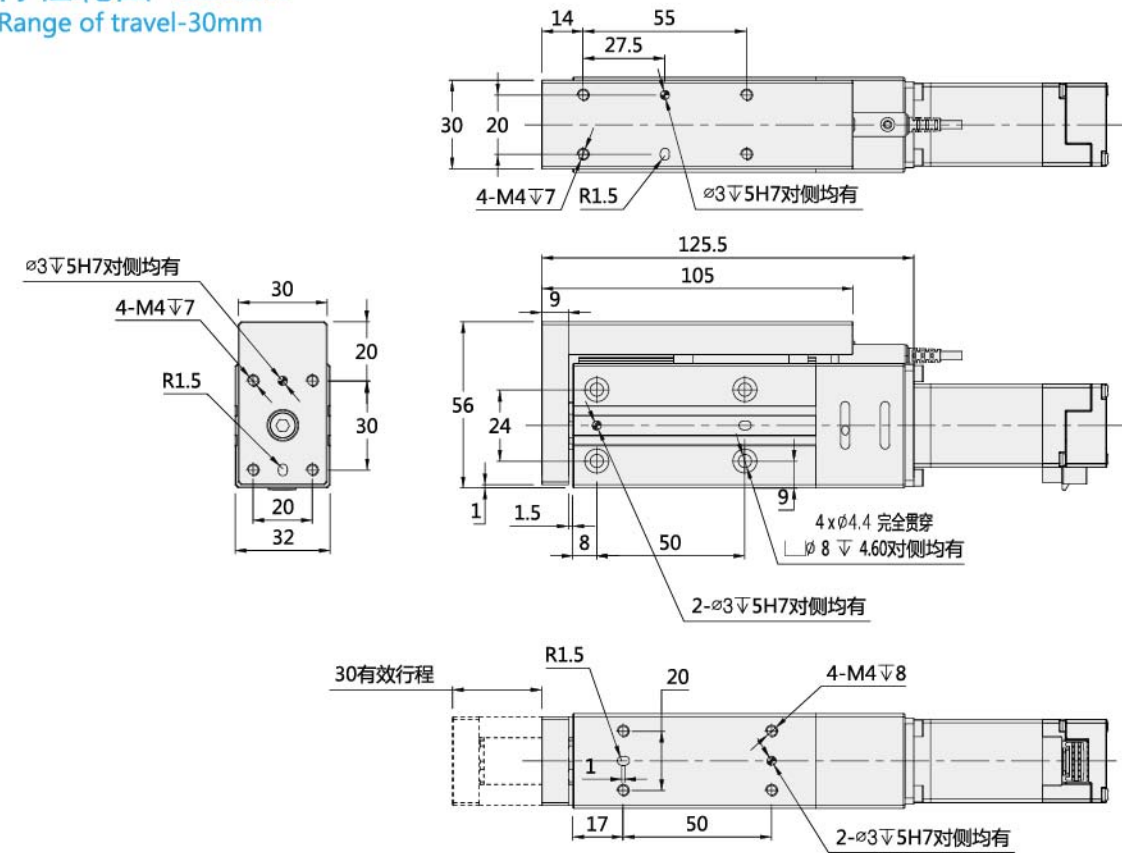

行程範圍-50MM Range of travel-50mm

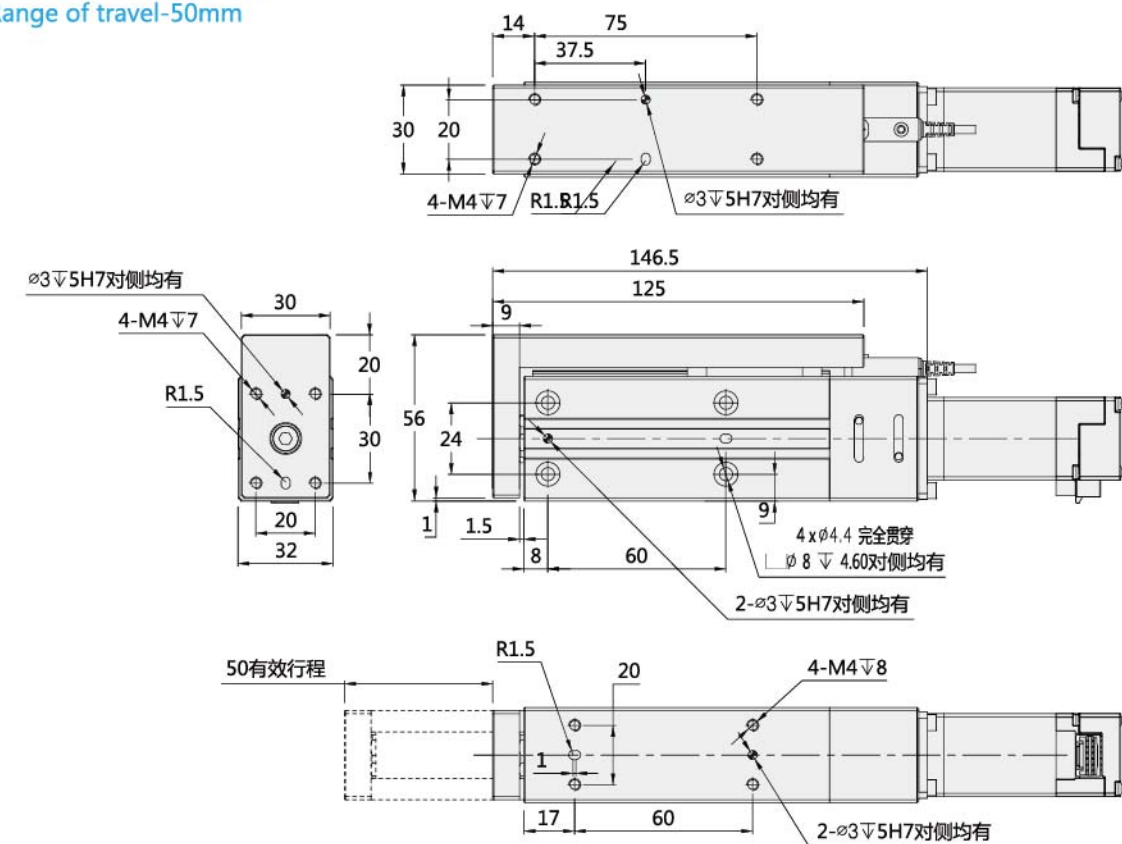

型號表示方式 Guide for Model Selection

LLH20 -L2 -S30 _

本體型號 Base Style	滾珠絲杆導程 (螺距) Ball Screw Lead	行程 Stroke(mm)	感應器類型 Sensor type
L2	2mm	30	无 NPN
L5	5mm	50	P PNP

速度與負載 Speed and load

水平使用

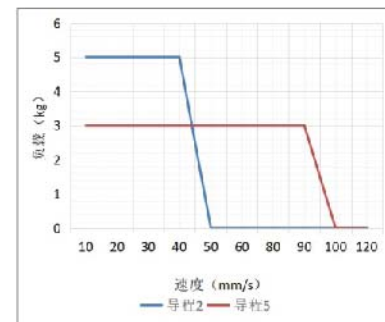

垂直使用

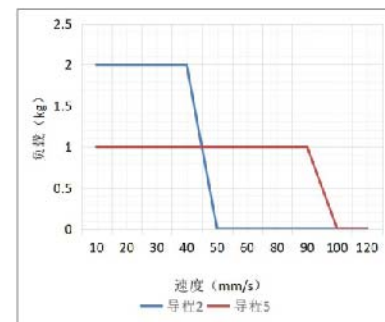

基本規格 Specification

馬達尺寸 (mm) Motor(mm)	28	
滾珠絲杆導程-螺距(mm) Ball Lead(mm)	2	5
最高速度(mm/s) Maximum Payload(mm/s)	40	100
最大負載 Maximum load	(水平使用)Horizontal	5 3
	(垂直使用)Vertical	2 1
額定推力(N) Rated thrust	301 120	
行程範圍 (mm) Range of travel	30/50	
絲杆外徑(mm) Screw diameter	\varnothing 8	
重複位置精度(mm) Repeatability	\pm 0.02(C7)	
導軌規格Guide specification	49MM(一體式)	

軌道內嵌型電動滑臺-LBTH40

TRACK EMBEDDED ELECTRIC SLIDER

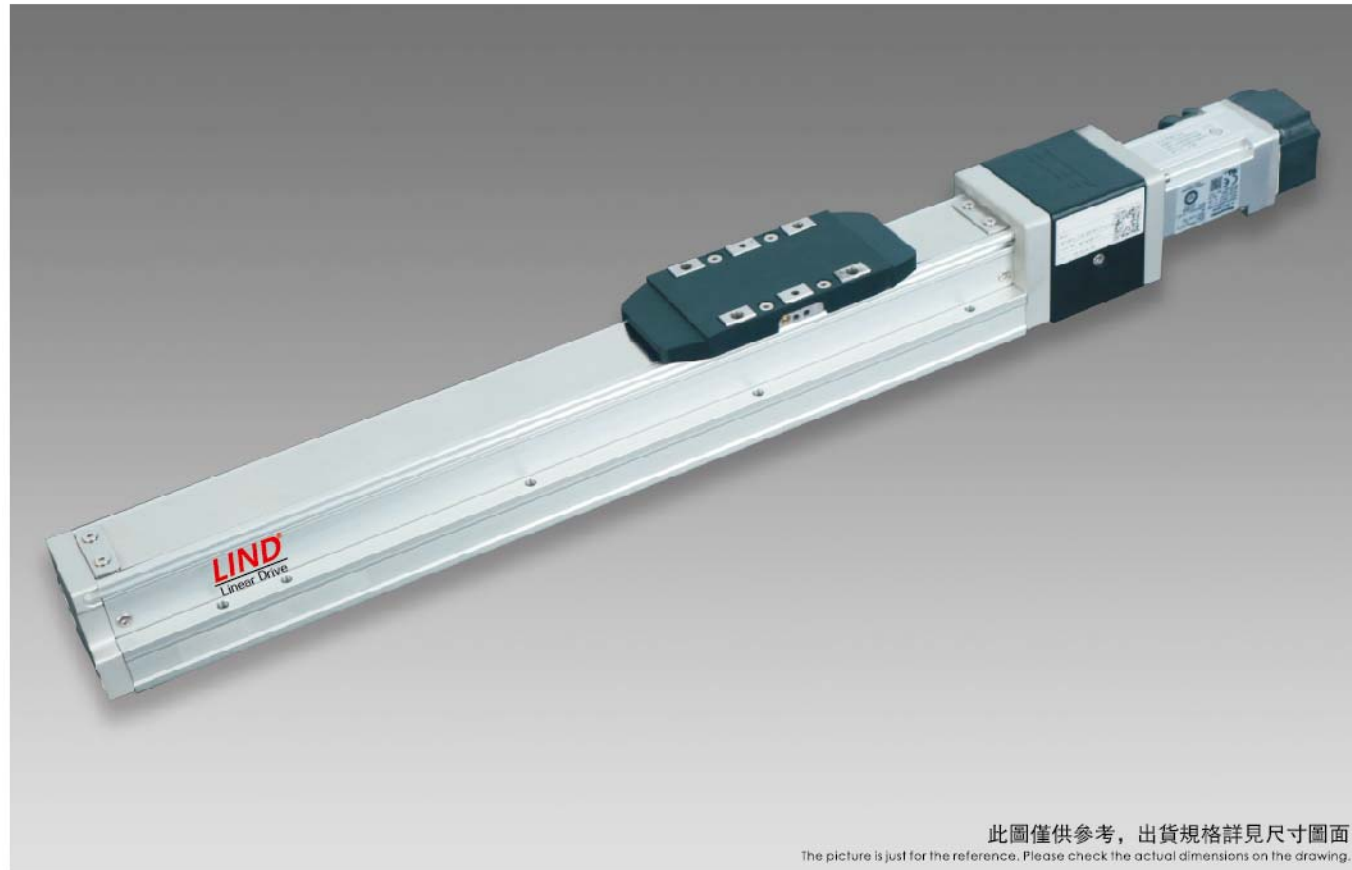

此圖僅供參考，出貨規格詳見尺寸圖面
The picture is just for the reference. Please check the actual dimensions on the drawing.

- 最大行程50mm Maximum Stroke
- 最高速度100mm/s Maximum Speed
- 馬達容量100W Motor Output
- 滾珠螺桿 Ø 10mm Ball Screw

型號表示方式 Ordering Method

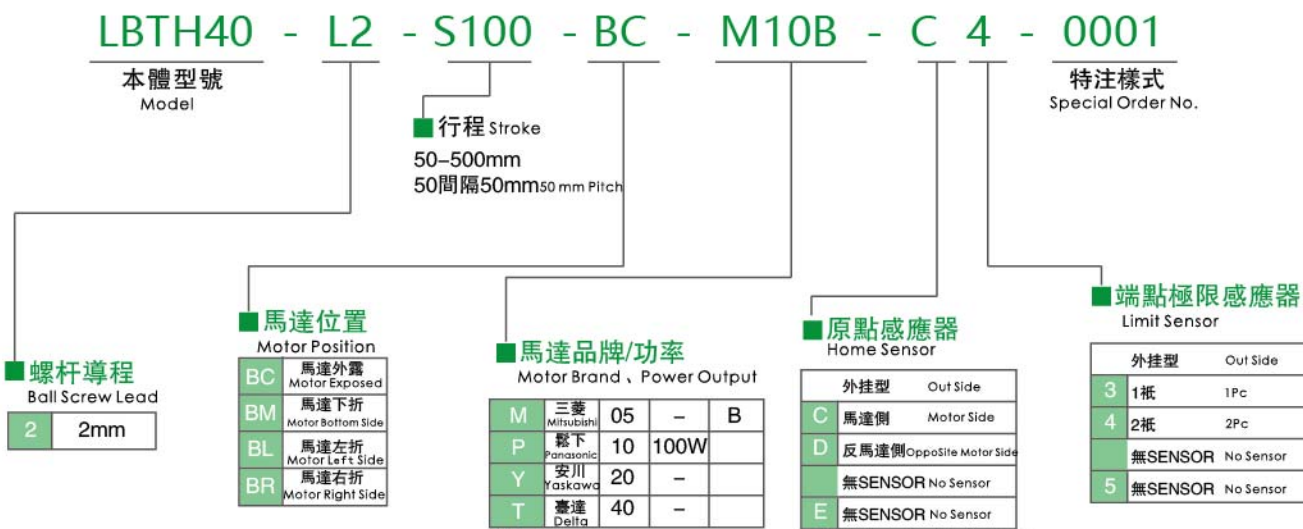

*若無制車則不表示。
If No Brake No Description.

*選擇行程50時，有以下限制。
When the stroke is 50 mm, the sensor installation has the following restrictions:

1. 原點與極限需放置于不同側
Home sensor and limit sensor has to be installed on the different side of body.

基本樣式 Specification

規格 Spec	重複位置精度(mm) Repeatability (mm)	±0.01
	螺桿導程(mm) Ball Screw Lead (mm)	2
	最高速度(mm/s) Maximum Speed (mm/s)	100
	最大可搬重量(kg) Repeatability (kg)	水平使用(kg) Horizontal (kg) 25 垂直使用(kg) Vertical (kg) 8
	定額推力(N) Rated Thrust (N)	1708
部品 Parts	標準行程(mm) Stroke Pitch (mm)	50-500mm/50mm間隔 50 mm Pitch
	AC伺服馬達容量(W) AC Servo Motor Output (W)	100
	滾珠螺桿外徑φ (mm) Ball Screw Ø (mm)	C7Ø10
	聯軸器(mm) Coupling (mm)	7X8
	原點感應器 Home Sensor	外挂 Outside

*行程超過300時，會產生螺桿偏擺，此時請將速度調降。
When the stroke is over 300 mm, the run-out of the ball screw will occur.

*馬達加減速設定0.2秒。
Acceleration and deceleration value is set 0.2 second.

感應器接線圖<原點機端點> Sensor Layout

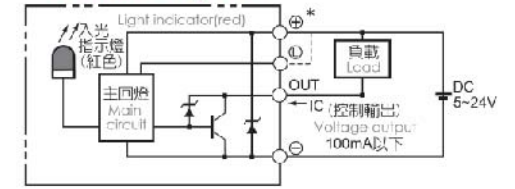

容許負載力矩表 Allowable Overhang

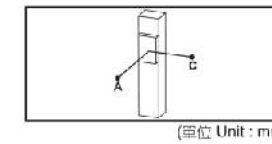
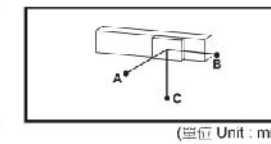
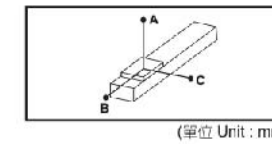

靜態容許負載慣量 Static Loading Moment

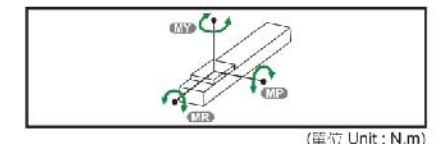

水平安裝 Horizontal Installation	A	B	C
導程 2 Lead 2	12kg	720	71
導程 4 Lead 4	15kg	550	47
導程 5 Lead 5	20kg	355	34
導程 10 Lead 10	25kg	255	25

壁掛安裝 Wall Installation	A	B	C
導程 2 Lead 2	12kg	94	69
導程 4 Lead 4	18kg	56	44
導程 5 Lead 5	25kg	34	30
導程 10 Lead 10	15kg	58	47
導程 20 Lead 20	20kg	40	34
導程 25 Lead 25	25kg	28	25

垂直安裝 Vertical Installation	A	C
導程 2 Lead 2	4kg	233
導程 4 Lead 4	8kg	118
導程 5 Lead 5	4kg	205
導程 10 Lead 10	8kg	104

MY	79
MP	79
MR	116

*力矩表所表示的數據，代表重心。
The torque value in the chart indicate the center of gravity.
*符合型錄規範的正常試用下，保證壽命為10000公裏。
Operation life is 10,000km when the product is using under the specified conditions.
*倒吊使用無法套用標準規範，如有需求請諮詢我司業務。
Data information is not for ceiling-mount inverse use. Contact us for the details if you want to apply ceiling-mount inverse usage.

搭配伺服馬達一覽表 Suitable Motor Brand

品牌 Brand	馬達記號 Mark	制車有無 Brake	馬達容量 Watt	電源電壓 AC-Voltage	伺服馬達型號 Motor Model	驅動器型號 Driver Model
三菱 Mitsubishi	M	無制車 (水平式樣) No Brake (Horizontal Type)	100	220	HG-KR13	MR-J4-10A
		有制車 (垂直式樣) With Brake (Horizontal Type)	100	220	HG-KR13B	MR-J4-10A
松下 Panasonic	P	無制車 (水平式樣) No Brake (Horizontal Type)	100	220	MSMD012G1U	MADHT1505
		有制車 (垂直式樣) With Brake (Horizontal Type)	100	220	MSMD012G1V	MADHT1505
臺達 Delta	T	無制車 (水平式樣) No Brake (Horizontal Type)	100	220	ECMA-C20401ES	ASD-B20121-B
		有制車 (垂直式樣) With Brake (Horizontal Type)	100	220	ECMA-C20401FS	ASD-B20121-B

BC馬達外露 Motor Exposed

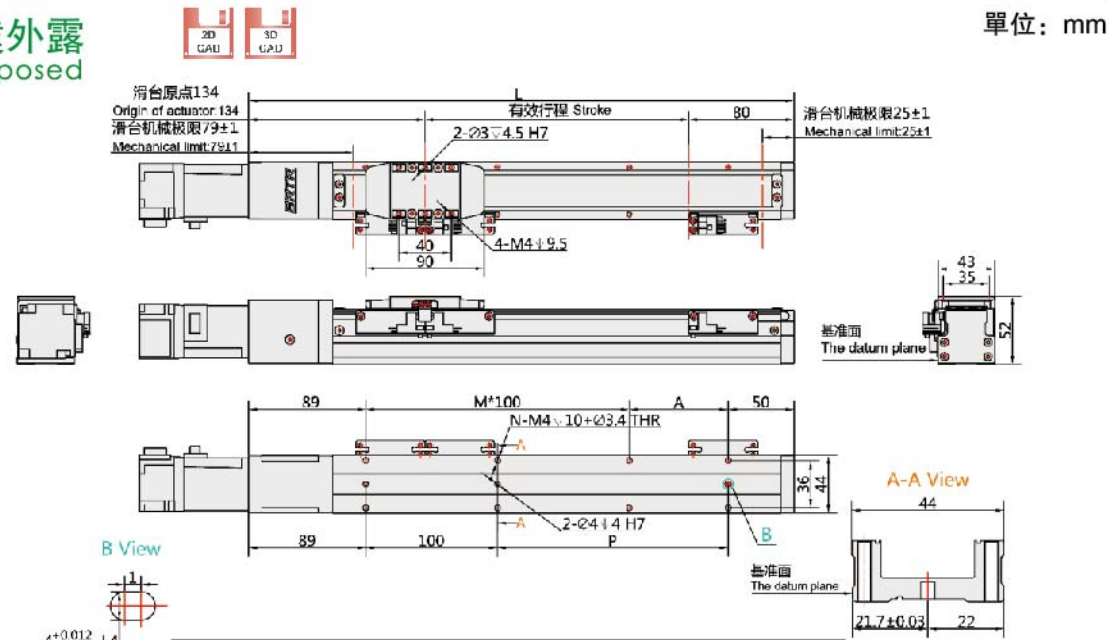

有效行程	标准行程									
	50	100	150	200	250	300	350	400	450	500
L	264	314	364	414	464	514	564	614	664	714
A	25	75	25	75	25	75	25	75	25	75
M	1	1	2	2	3	3	4	4	5	5
N	6	6	8	8	10	10	12	12	14	14
P	25	75	125	175	225	275	325	375	425	475
KG	1.36	1.61	1.86	2.11	2.35	2.6	2.85	3.1	3.34	3.59

BL馬達左折 Motor Left Side

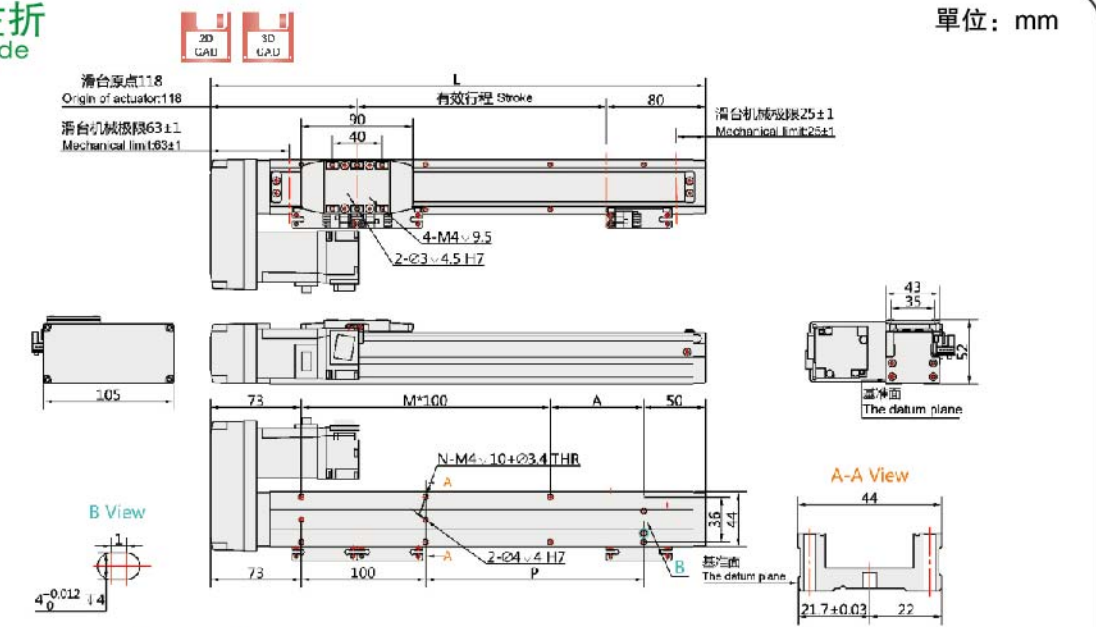

有效行程	标准行程									
	50	100	150	200	250	300	350	400	450	500
L	246	296	346	396	446	496	546	596	646	696
A	25	75	25	75	25	75	25	75	25	75
M	0	0	1	1	2	2	3	3	4	4
N	4	4	6	6	8	8	10	10	12	12
P	25	75	125	175	225	275	325	375	425	475
KG	1.66	1.91	2.16	2.4	2.65	2.9	3.14	3.39	3.64	3.89

BM馬達下折 Motor Bottom Side

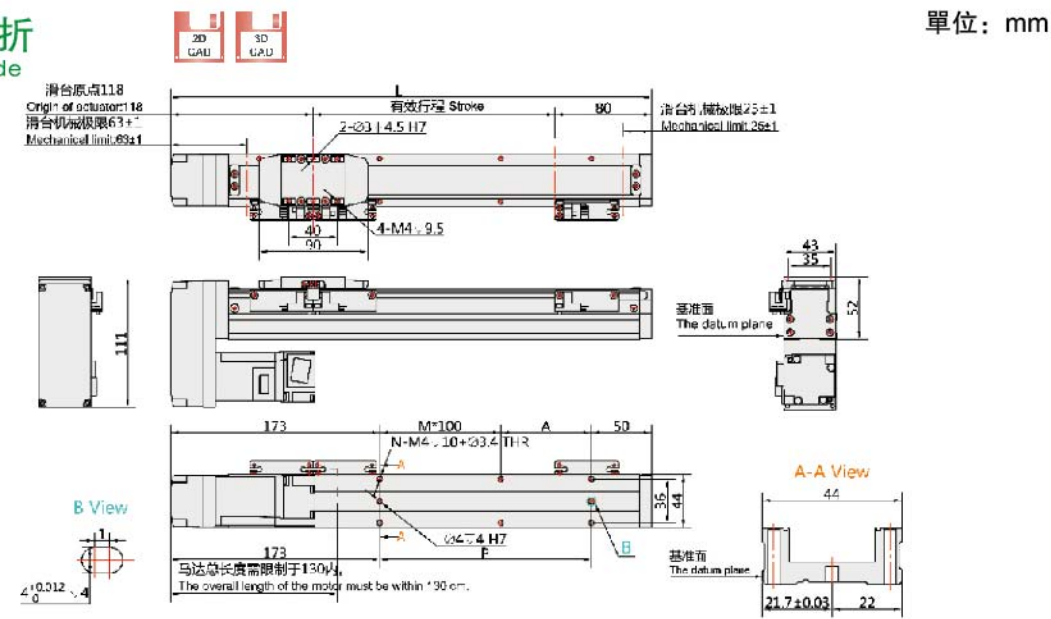

有效行程	标准行程									
	50	100	150	200	250	300	350	400	450	500
L	246	296	346	396	446	496	546	596	646	696
A	25	75	25	75	25	75	25	75	25	75
M	0	0	1	1	2	2	3	3	4	4
N	4	4	6	6	8	8	10	10	12	12
P	25	75	125	175	225	275	325	375	425	475
KG	1.66	1.91	2.16	2.4	2.65	2.9	3.14	3.39	3.64	3.89

BR馬達右折 Motor Right Side

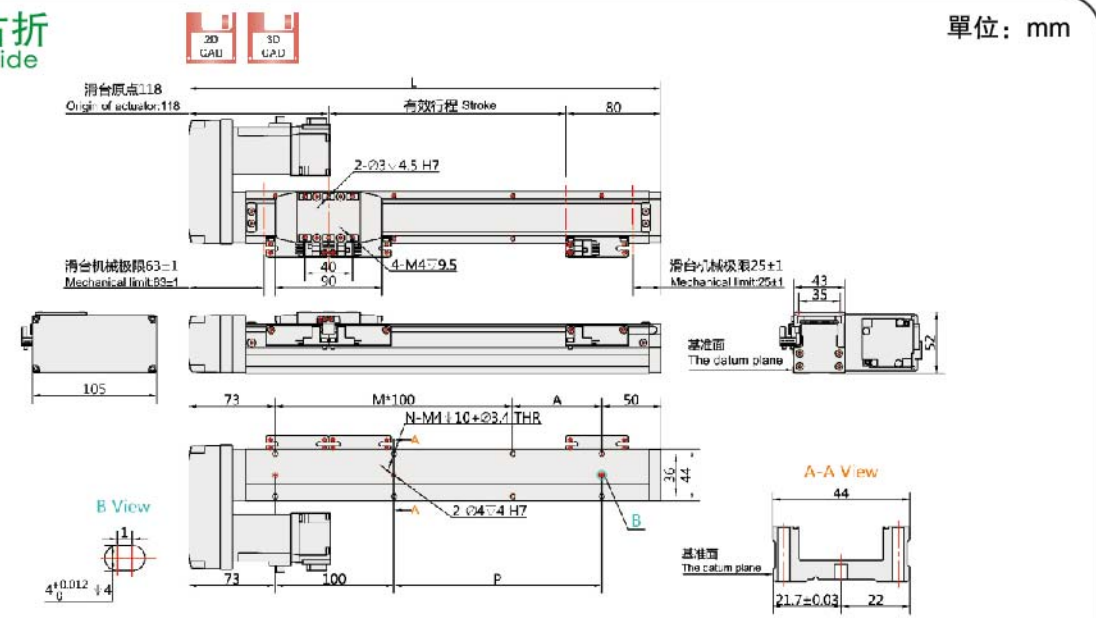

有效行程	标准行程									
	50	100	150	200	250	300	350	400	450	500
L	246	296	346	396	446	496	546	596	646	696
A	25	75	25	75	25	75	25	75	25	75
M	1	1	2	2	3	3	4	4	5	5
N	6	6	8	8	10	10	12	12	14	14
P	25	75	125	175	225	275	325	375	425	475
KG	1.66	1.91	2.16	2.4	2.65	2.9	3.14	3.39	3.64	3.89

軌道內嵌型電動滑臺-LBTH50

TRACK EMBEDDED ELECTRIC SLIDER

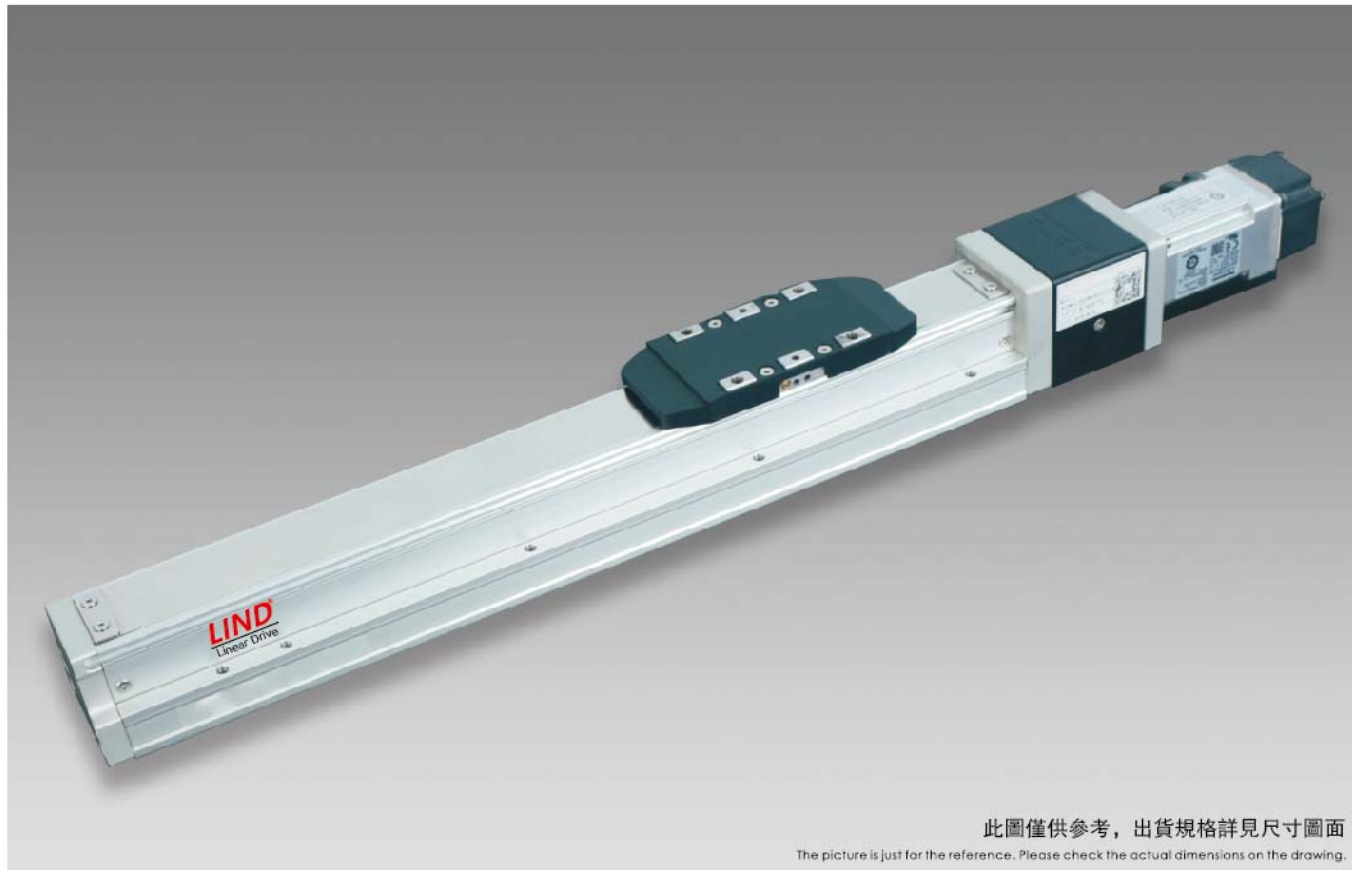

此圖僅供參考，出貨規格詳見尺寸圖面
The picture is just for the reference. Please check the actual dimensions on the drawing.

- 最大行程800mm Maximum Stroke
- 最高速度500mm/s Maximum Speed
- 馬達容量100W Motor Output
- 滾珠螺桿 Ø 12mm Ball Screw

型號表示方式 Ordering Method

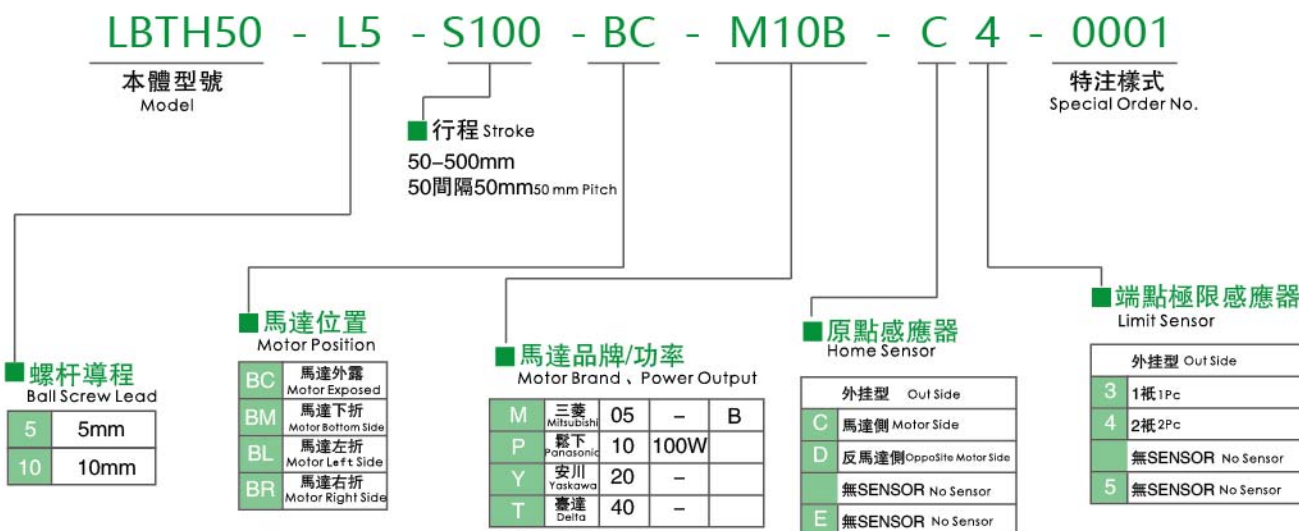

*若無制動則不表示。
If No Brake No Description.

*選擇行程50時，有以下限制。
When the stroke is 50 mm, the sensor installation has the following restrictions:

- 無法選用C4 D4規格。
C4&D4 will not be available for installation (order) option.
- 原點與極限需放置于不同側。
Home sensor and limit sensor has to be installed on the different side of body.
- 滑座左右兩側皆需安裝感應片

基本樣式 Specification

規格 Spec	重複位置精度(mm) Repeatability (mm)	±0.01		
	螺桿導程(mm) Ball Screw Lead (mm)	5	10	
	最高速度(mm/s) Maximum Speed (mm/s)	250	500	
	最大可搬重量(kg) Repeatability (kg)	水平使用(kg) Horizontal (kg)	30	15
		垂直使用(kg) Vertical (kg)	10	5
	定額推力(N) Rated Thrust (N)	341	170	
部品 Parts	標準行程(mm) Stroke Pitch (mm)	50-800mm/50mm間隔 50 mm Pitch		
	AC伺服馬達容量(W) AC Servo Motor Output (W)	100		
	滾珠螺桿外徑(φ) Ball Screw Ø (mm)	C7Ø12		
	聯軸器(mm) Coupling (mm)	7X8		
	原點感應器 Home Sensor	外挂 Outside	FF-U674(NPN)	

*行程超過600時，會產生螺桿偏擺，此時請將速度調降。
When the stroke is over 600 mm, the run-out of the ballscrew will occur. we recommend to low down the working speed under this circumstances.
*馬達加減速設定0.2秒。
Acceleration and deceleration value is set 0.2 second.

容許負載力矩表 Allowable Overhang

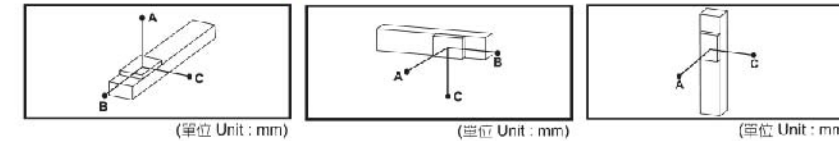

水平安裝 Horizontal Installation				壁掛安裝 Wall Installation				垂直安裝 Vertical Installation			
導程 Lead	A	B	C	導程 Lead	A	B	C	導程 Lead	A	C	
4	10kg	700	80	110	10kg	110	80	700	6kg	155	155
5	20kg	480	36	50	20kg	50	36	480	8kg	117	117
10	30kg	290	21	27	30kg	27	21	290	10kg	96	96
4	10kg	650	75	100	10kg	100	75	650	6kg	145	145
5	20kg	440	32	45	20kg	45	32	420	8kg	110	110
10	30kg	270	19	25	30kg	25	19	260	10kg	90	90
4	5kg	600	145	185	5kg	180	145	600	1kg	800	800
5	10kg	370	70	85	10kg	85	68	370	3kg	260	260
10	15kg	250	42	52	15kg	52	42	250	5kg	155	155

感應器接線圖<原點機端點> Sensor Layout

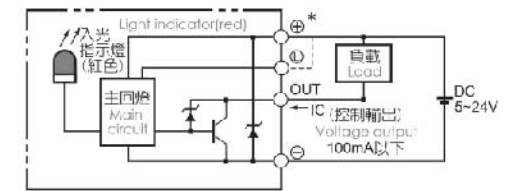

靜態容許負載慣量 Static Loading Moment

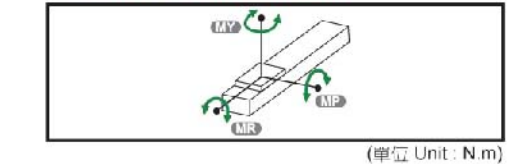

MY	103
MP	103
MR	144

*力矩表所表示的數據，代表重心。
The torque value in the chart indicate the center of gravity.
*符合型錄規範的正常試用下，保證壽命為10000公裏。
Operation life is 10,000km when the product is using under the specified conditions.
*例吊使用無法套用標準規範，如有需求請諮詢我業務。
Data information is not for ceiling-mount inverse use. Contact us for the details if you want to apply ceiling-mount inverse usage.

搭配伺服馬達一覽表 Suitable Motor Brand

品牌 Brand	馬達記號 Mark	剎車有無 Brake	馬達容量 Watt	電源電壓 AC-Voltage	伺服馬達型號 Motor Model	驅動器型號 Driver Model
三菱 Mitsubishi	M	無剎車(水平式樣) No Brake (Horizontal Type)	100	220	HG-KR13	MR-J4-10A
		有剎車(垂直式樣) With Brake (Vertical Type)	100	220	HG-KR13B	MR-J4-10A
松下 Panasonic	P	無剎車(水平式樣) No Brake (Horizontal Type)	100	220	MSMD012G1U	MADHT1505
		有剎車(垂直式樣) With Brake (Vertical Type)	100	220	MSMD012G1V	MADHT1505
臺達 Delta	T	無剎車(水平式樣) No Brake (Horizontal Type)	100	220	ECMA-C20401ES	ASD-B20121-B
		有剎車(垂直式樣) With Brake (Vertical Type)	100	220	ECMA-C20401FS	ASD-B20121-B

BC馬達外露 Motor Exposed



單位: mm

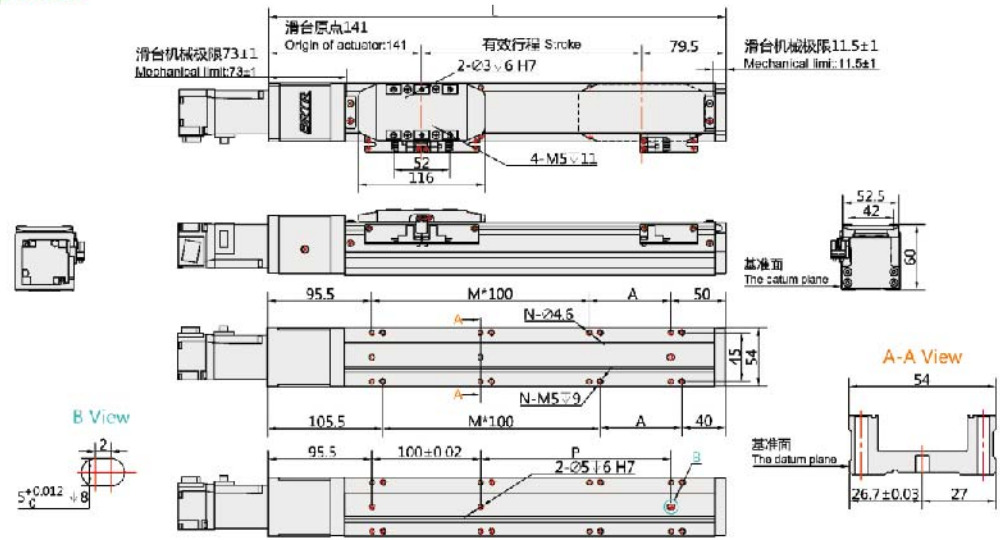

有效行程	标准行程										容许行程							
	50	100	150	200	250	300	350	400	450	500	550	600	650	700	750	800		
L	270.5	320.5	370.5	420.5	470.5	520.5	570.5	620.5	670.5	720.5	770.5	820.5	870.5	920.5	970.5	1020.5		
A	25	75	25	75	25	75	25	75	25	75	25	75	25	75	25	75		
M	1	1	2	2	3	3	4	4	5	5	6	6	7	7	8	8		
N	6	6	8	8	10	10	12	12	14	14	16	16	18	18	20	20		
P	25	75	125	175	225	275	325	375	425	475	525	575	625	675	725	775		
KG	2.23	2.42	2.62	2.82	3.01	3.21	3.41	3.6	3.8	4	4.19	4.39	4.59	4.78	4.98	5.18		

BL馬達左折 Motor Left Side



單位: mm

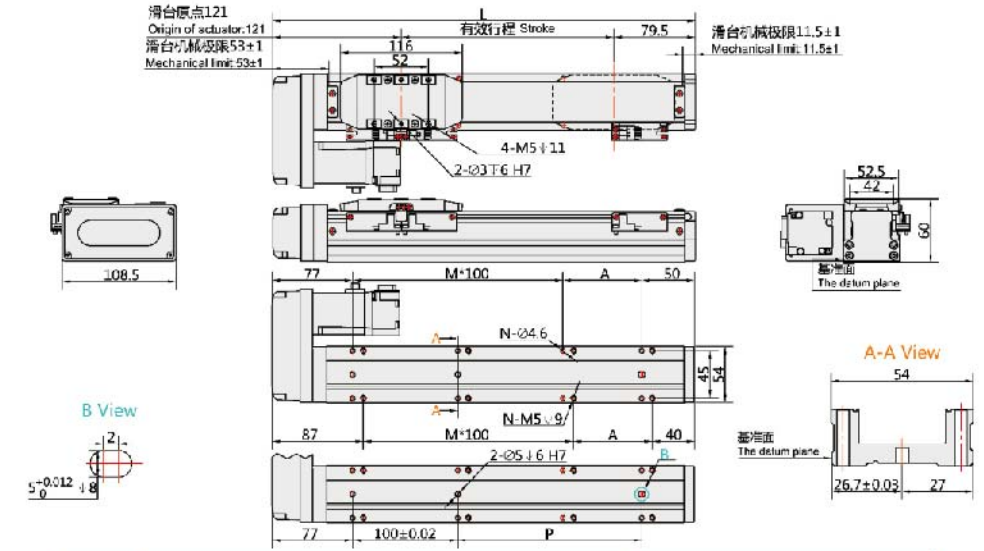

有效行程	标准行程										容许行程							
	50	100	150	200	250	300	350	400	450	500	550	600	650	700	750	800		
L	250.5	300.5	350.5	400.5	450.5	500.5	550.5	600.5	650.5	700.5	750.5	800.5	850.5	900.5	950.5	1000.5		
A	25	75	25	75	25	75	25	75	25	75	25	75	25	75	25	75		
M	1	1	2	2	3	3	4	4	5	5	6	6	7	7	8	8		
N	6	6	8	8	10	10	12	12	14	14	16	16	18	18	20	20		
P	25	75	125	175	225	275	325	375	425	475	525	575	625	675	725	775		
KG	2.4	2.59	2.79	2.99	3.18	3.38	3.58	3.77	3.97	4.17	4.36	4.56	4.76	4.95	5.15	5.35		

BM馬達下折 Motor Bottom Side



單位: mm

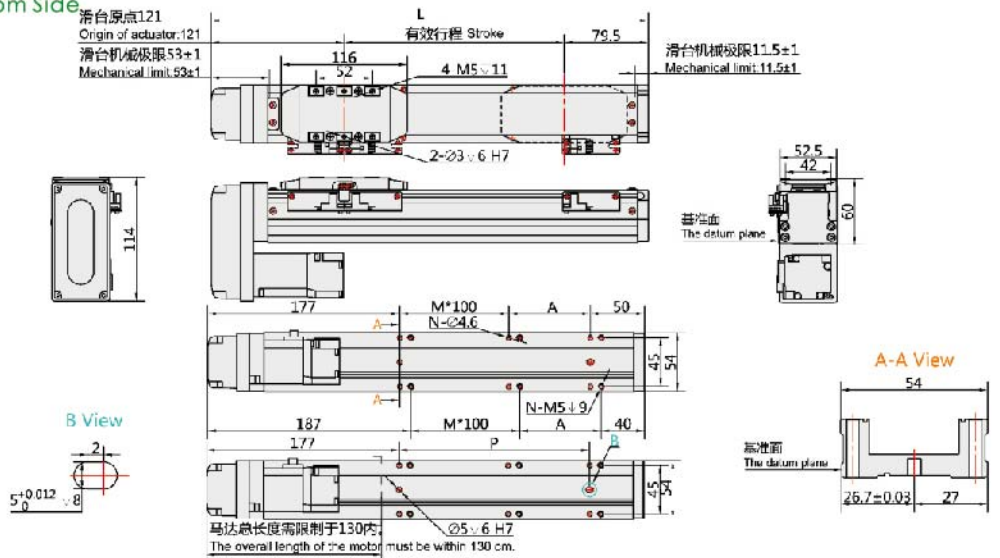

有效行程	标准行程										容许行程							
	50	100	150	200	250	300	350	400	450	500	550	600	650	700	750	800		
L	250.5	300.5	350.5	400.5	450.5	500.5	550.5	600.5	650.5	700.5	750.5	800.5	850.5	900.5	950.5	1000.5		
A	25	75	25	75	25	75	25	75	25	75	25	75	25	75	25	75		
M	0	0	1	1	2	2	3	3	4	4	5	5	6	6	7	7		
N	4	4	6	6	8	8	10	10	12	12	14	14	16	16	18	18		
P	25	75	125	175	225	275	325	375	425	475	525	575	625	675	725	775		
KG	2.4	2.59	2.79	2.99	3.18	3.38	3.58	3.77	3.97	4.17	4.36	4.56	4.76	4.95	5.15	5.35		

BR馬達右折 Motor Right Side



單位: mm

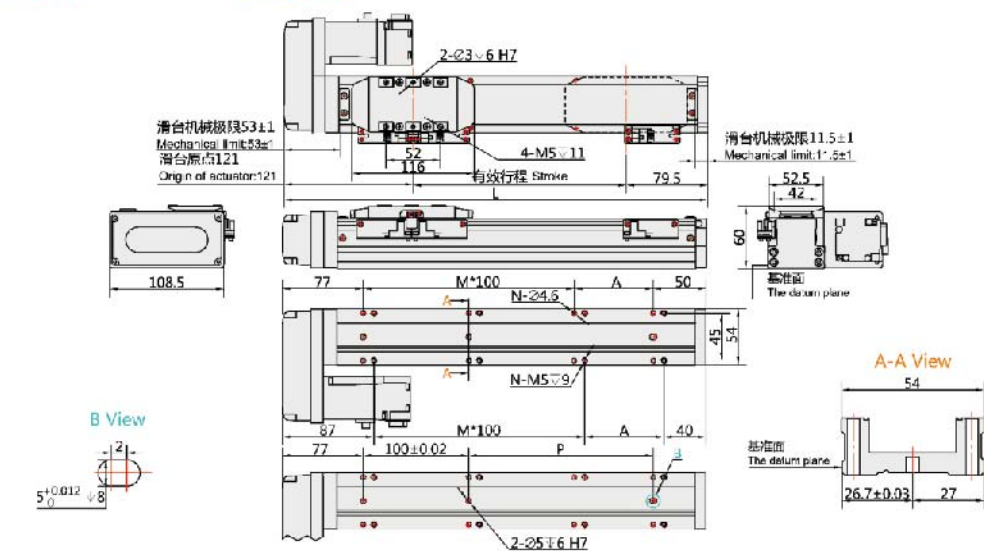

有效行程	标准行程										容许行程							
	50	100	150	200	250	300	350	400	450	500	550	600	650	700	750	800		
L	250.5	300.5	350.5	400.5	450.5	500.5	550.5	600.5	650.5	700.5	750.5	800.5	850.5	900.5	950.5	1000.5		
A	25	75	25	75	25	75	25	75	25	75	25	75	25	75	25	75		
M	1	1	2	2	3	3	4	4	5	5	6	6	7	7	8	8		
N	6	6	8	8	10	10	12	12	14	14	16	16	18	18	20	20		
P	25	75	125	175	225	275	325	375	425	475	525	575	625	675	725	775		
KG	2.4	2.59	2.79	2.99	3.18	3.38	3.58	3.77	3.97	4.17	4.36	4.56	4.76	4.95	5.15	5.35		

軌道內嵌型電動滑臺-LBTH80

TRACK EMBEDDED ELECTRIC SLIDER

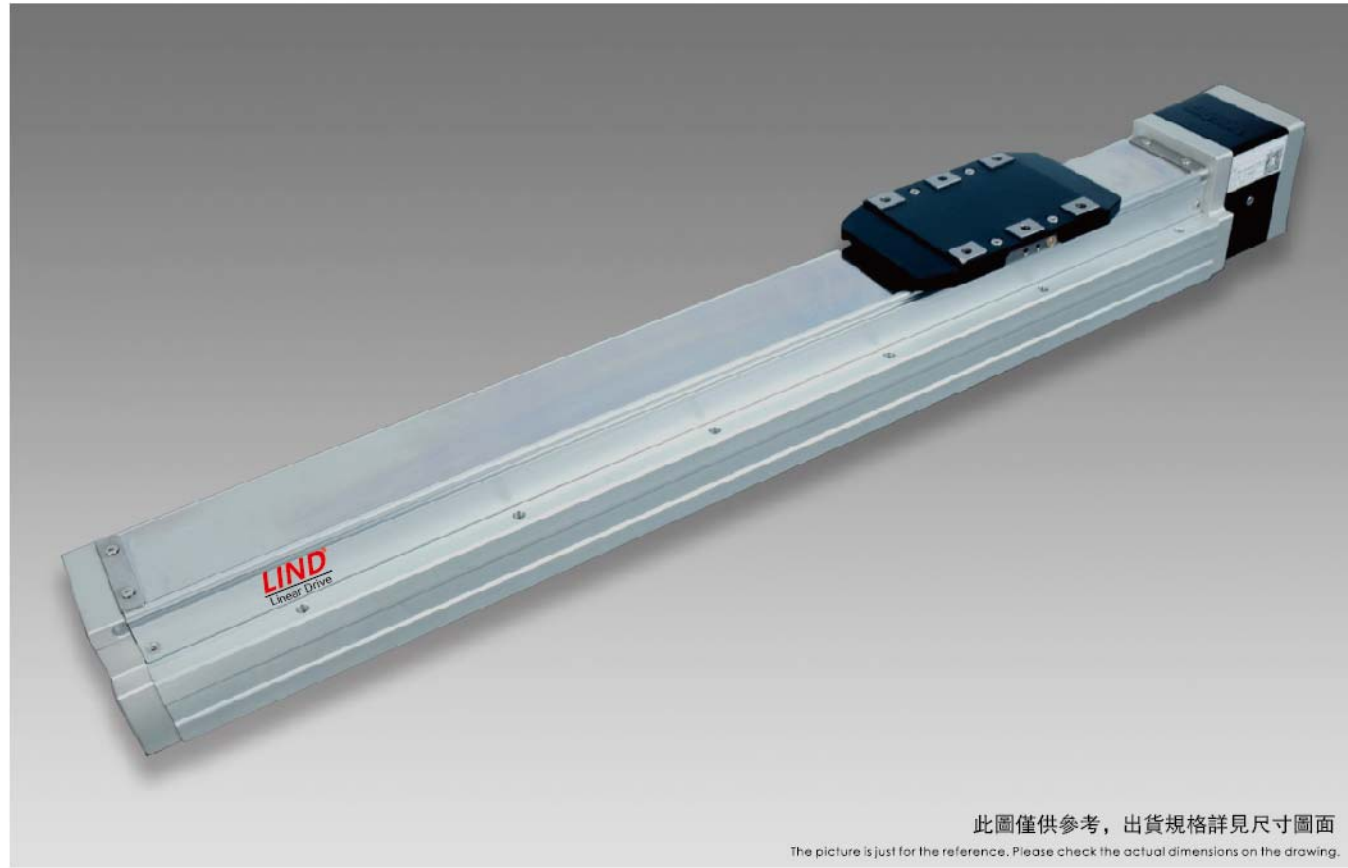

此圖僅供參考，出貨規格詳見尺寸圖面
The picture is just for the reference. Please check the actual dimensions on the drawing.

- 最大行程1000mm Maximum Stroke
- 最高速度1000mm/s Maximum Speed
- 馬達容量200W Motor Output
- 滾珠螺桿 Ø 16mm Ball Screw

型號表示方式 Ordering Method

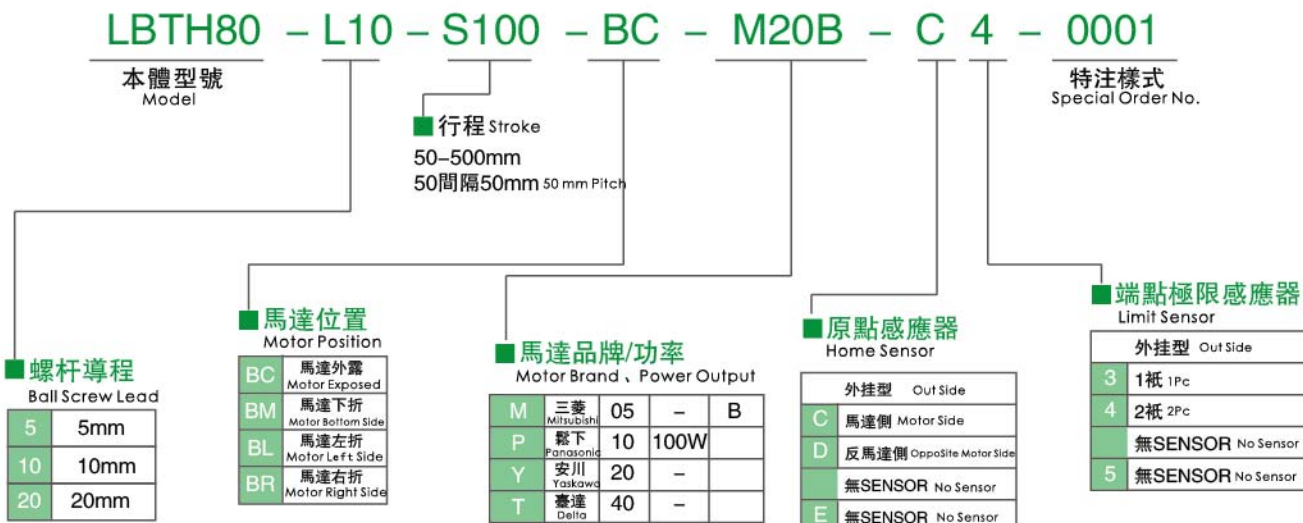

- *若無制動則不表示。 If No Brake No Description.
- *選擇行程50時，有以下限制。 When the stroke is 50 mm, the sensor installation has the following restrictions:
 - 無法選用C4 D4規格。 C4&D4 will not be available for installation (order) option.
 - 原點與極限需放置于不同側。 Home sensor and limit sensor has to be installed on the different side of body.
 - 滑座左右兩側皆需安裝感應片

基本樣式 Specification

規格 Spec	重複位置精度(mm) Repeatability (mm)	±0.01			
	螺桿導程(mm) Ball Screw Lead (mm)	5	10	20	
	最高速度(mm/s) Maximum Speed (mm/s)	250	500	1000	
	最大可搬重量(kg) Repeatability (kg)	水平使用(kg) Horizontal (kg)	50	30	18
		垂直使用(kg) Vertical (kg)	15	8	3
	定額推力(N) Rated Thrust (N)	683	341	174	
部品 Parts	標準行程(mm) Stroke Pitch (mm)	50-1000mm/50間隔 50 mm Pitch			
	AC伺服馬達容量(W) AC Servo Motor Output (W)	200			
	滾珠螺桿外徑(φ) Ball Screw Ø (mm)	C7Ø16			
	聯軸器(mm) Coupling (mm)	10X14/11(註1)			
	原點感應器 Home Sensor	外掛 Outside	FF-U674(NPN)		

*行程超過750時，會產生螺桿偏擺，此時請將速度調降。
When the stroke is over 750 mm, the run-out of the ballscrew will occur. we recommend to low down the working speed under this circumstances.
*馬達加減速設定0.2秒。
Acceleration and deceleration value is set 0.2 second.
注1: 使用Panasonic200馬達時，馬達軸心威成Ø11；其他品牌，馬達軸心為Ø14
Motor(200W) Shaft Diameter: Panasonic;11mm;Other:14mm.

容許負載力矩表 Allowable Overhang

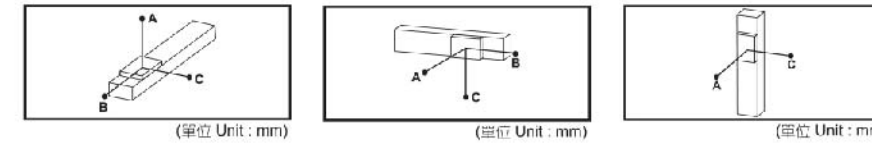

水平安裝 Horizontal Installation	A	B	C
導程 5 Lead	20kg	1560	237
	35kg	890	126
	50kg	550	82
導程 10 Lead	10kg	1730	412
	20kg	839	196
	30kg	541	124
導程 20 Lead	6kg	1213	493
	9kg	800	323
	18kg	592	238

壁掛安裝 Wall Installation	A	B	C
導程 5 Lead	20kg	214	1435
	35kg	113	845
	50kg	74	506
導程 10 Lead	10kg	370	1400
	20kg	176	800
	30kg	112	495
導程 20 Lead	6kg	444	760
	9kg	292	277
	18kg	214	544

感應器接線圖<原點機端點> Sensor Layout

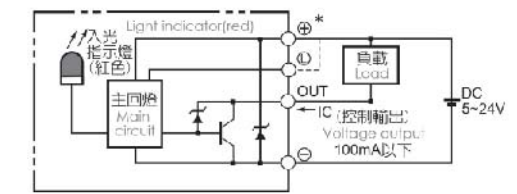

靜態容許負載慣量 Static Loading Moment

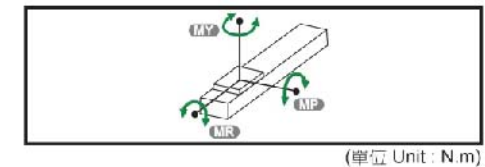

MY	318
MP	318
MR	626

*力矩表所表示的數據，代表重心
The torque value in the chart indicate the center of gravity.
*符合型錄規範的正常試用下，保證壽命為10000公裏
Operation life is 10,000km when the product is using under the specified conditions.
*倒吊使用無法套用標準規範，如有需求請諮詢我司業務
Data information is not for ceiling-mount inverse use. Contact us for the details if you want to apply ceiling-mount inverse usage.

搭配伺服馬達一覽表 Suitable Motor Brand

品牌 Brand	馬達記號 Mark	制動有無 Brake	馬達容量 Watt	電源電壓 AC-Voltage	伺服馬達型號 Motor Model	驅動器型號 Driver Model
三菱 Mitsubishi	M	無制動 (水平式樣) No Brake (Horizontal Type)	200	220	HG-KR23	MR-J4-20A
		有制動 (垂直式樣) With Brake (Vertical Type)	200	220	HG-KR23B	MR-J4-20A
鬆下 Panasonic	P	無制動 (水平式樣) No Brake (Horizontal Type)	200	220	MSMD022G1U	MADHT1507
		有制動 (垂直式樣) With Brake (Vertical Type)	200	220	MSMD022G1V	MADHT1507
臺達 Delta	T	無制動 (水平式樣) No Brake (Horizontal Type)	200	220	ECMA-C20602ES	ASD-B20221-B
		有制動 (垂直式樣) With Brake (Vertical Type)	200	220	ECMA-C20602FS	ASD-B20221-B

BC馬達外露 Motor Exposed

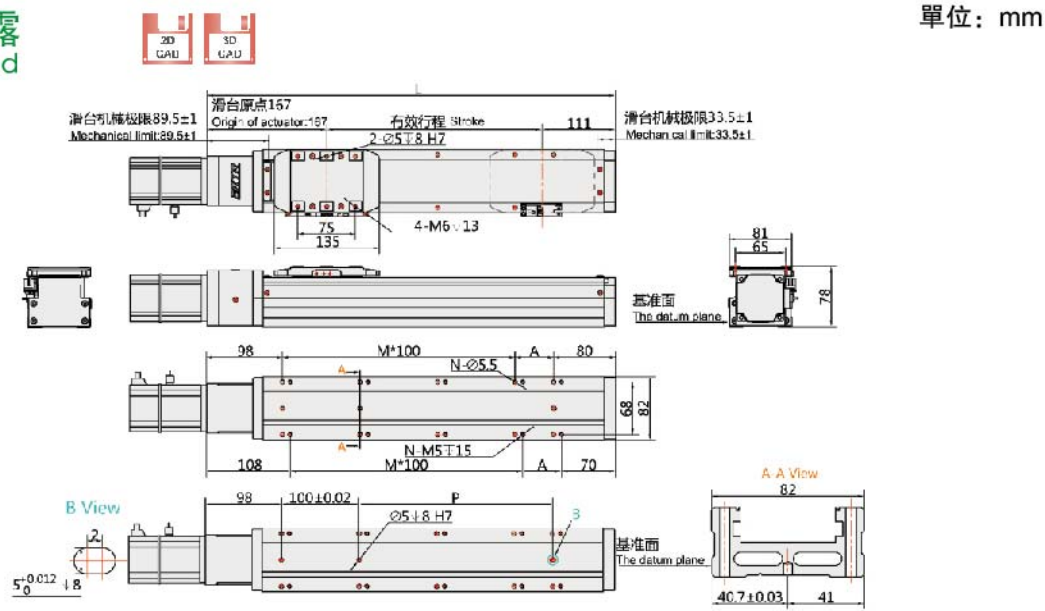

有效行程	标准行程										容许行程									
	50	100	150	200	250	300	350	400	450	500	550	600	650	700	750	800	850	900	950	1000
L	328	378	428	478	528	578	628	678	728	778	828	878	928	978	1028	1078	1128	1178	1228	1278
A	50	100	50	100	50	100	50	100	50	100	50	100	50	100	50	100	50	100	50	100
M	1	1	2	2	3	3	4	4	5	5	6	6	7	7	8	8	9	9	10	10
N	6	6	8	8	10	10	12	12	14	14	16	16	18	18	20	20	22	22	24	24
P	50	100	150	200	250	300	350	400	450	500	550	600	650	700	750	800	850	900	950	1000
KG	5.18	5.54	5.91	6.27	6.64	7	7.37	7.73	8.1	8.46	8.83	9.19	9.56	9.92	10.29	10.65	11.02	11.38	11.75	12.11

BL馬達左折 Motor Left Side

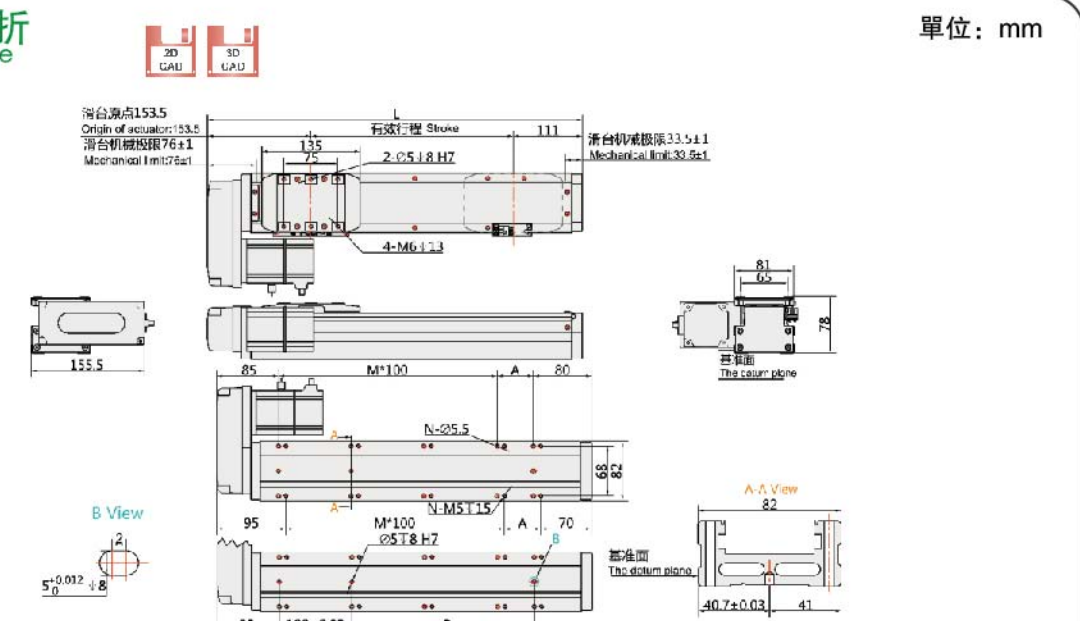

有效行程	标准行程										容许行程									
	50	100	150	200	250	300	350	400	450	500	550	600	650	700	750	800	850	900	950	1000
L	314.5	364.5	414.5	464.5	514.5	564.5	614.5	664.5	714.5	764.5	814.5	864.5	914.5	964.5	1014.5	1064.5	1114.5	1164.5	1214.5	1264.5
A	50	100	50	100	50	100	50	100	50	100	50	100	50	100	50	100	50	100	50	100
M	1	1	2	2	3	3	4	4	5	5	6	6	7	7	8	8	9	9	10	10
N	6	6	8	8	10	10	12	12	14	14	16	16	18	18	20	20	22	22	24	24
P	50	100	150	200	250	300	350	400	450	500	550	600	650	700	750	800	850	900	950	1000
KG	5.19	5.6	6.12	6.64	7.16	7.68	8.2	8.72	9.24	9.76	10.28	10.8	11.32	11.84	12.36	12.88	13.4	13.92	14.44	14.96

BM馬達下折 Motor Bottom Side

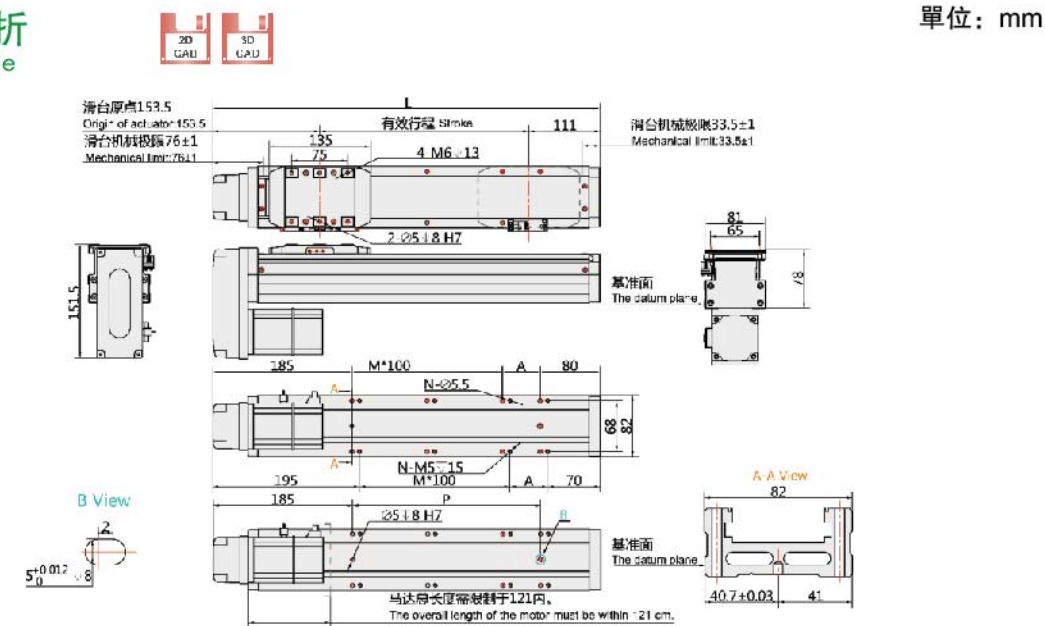

有效行程	标准行程										容许行程									
	50	100	150	200	250	300	350	400	450	500	550	600	650	700	750	800	850	900	950	1000
L	314.5	364.5	414.5	464.5	514.5	564.5	614.5	664.5	714.5	764.5	814.5	864.5	914.5	964.5	1014.5	1064.5	1114.5	1164.5	1214.5	1264.5
A	50	100	50	100	50	100	50	100	50	100	50	100	50	100	50	100	50	100	50	100
M	0	0	1	1	2	2	3	3	4	4	5	5	6	6	7	7	8	8	9	9
N	4	4	6	6	8	8	10	10	12	12	14	14	16	16	18	18	20	20	22	22
P	50	100	150	200	250	300	350	400	450	500	550	600	650	700	750	800	850	900	950	1000
KG	5.19	5.6	6.12	6.64	7.16	7.68	8.2	8.72	9.24	9.76	10.28	10.8	11.32	11.84	12.36	12.88	13.4	13.92	14.44	14.96

BR馬達右折 Motor Right Side

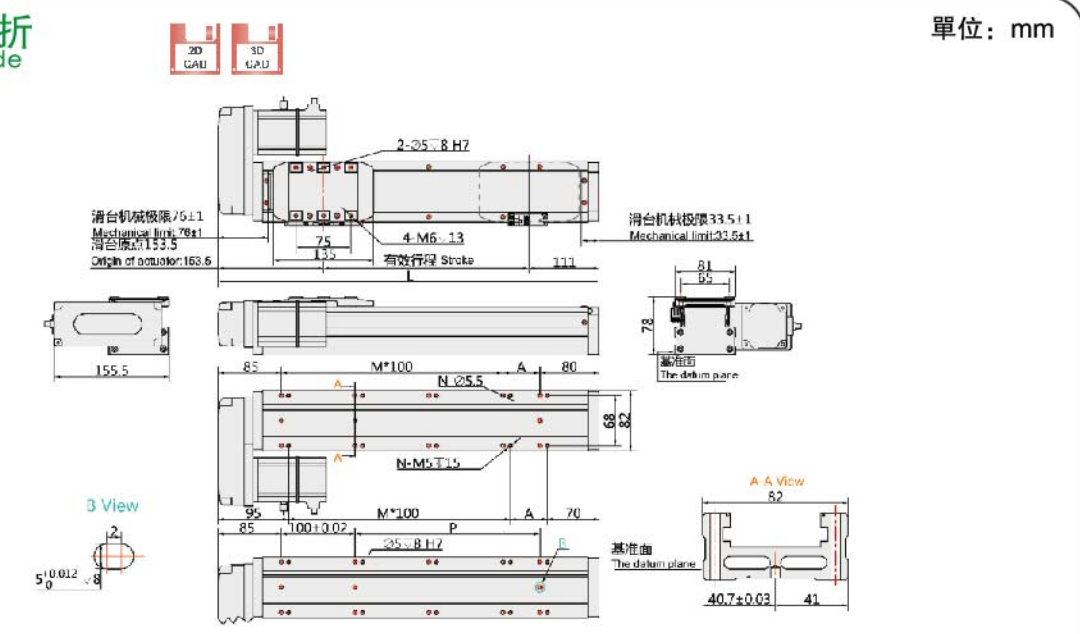

有效行程	标准行程										容许行程									
	50	100	150	200	250	300	350	400	450	500	550	600	650	700	750	800	850	900	950	1000
L	314.5	364.5	414.5	464.5	514.5	564.5	614.5	664.5	714.5	764.5	814.5	864.5	914.5	964.5	1014.5	1064.5	1114.5	1164.5	1214.5	1264.5
A	50	100	50	100	50	100	50	100	50	100	50	100	50	100	50	100	50	100	50	100
M	1	1	2	2	3	3	4	4	5	5	6	6	7	7	8	8	9	9	10	10
N	6	6	8	8	10	10	12	12	14	14	16	16	18	18	20	20	22	22	24	24
P	50	100	150	200	250	300	350	400	450	500	550	600	650	700	750	800	850	900	950	1000
KG	5.19	5.6	6.12	6.64	7.16	7.68	8.2	8.72	9.24	9.76	10.28	10.8	11.32	11.84	12.36	12.88	13.4	13.92	14.44	14.96

軌道內嵌型電動滑臺-LBTH120

TRACK EMBEDDED ELECTRIC SLIDER

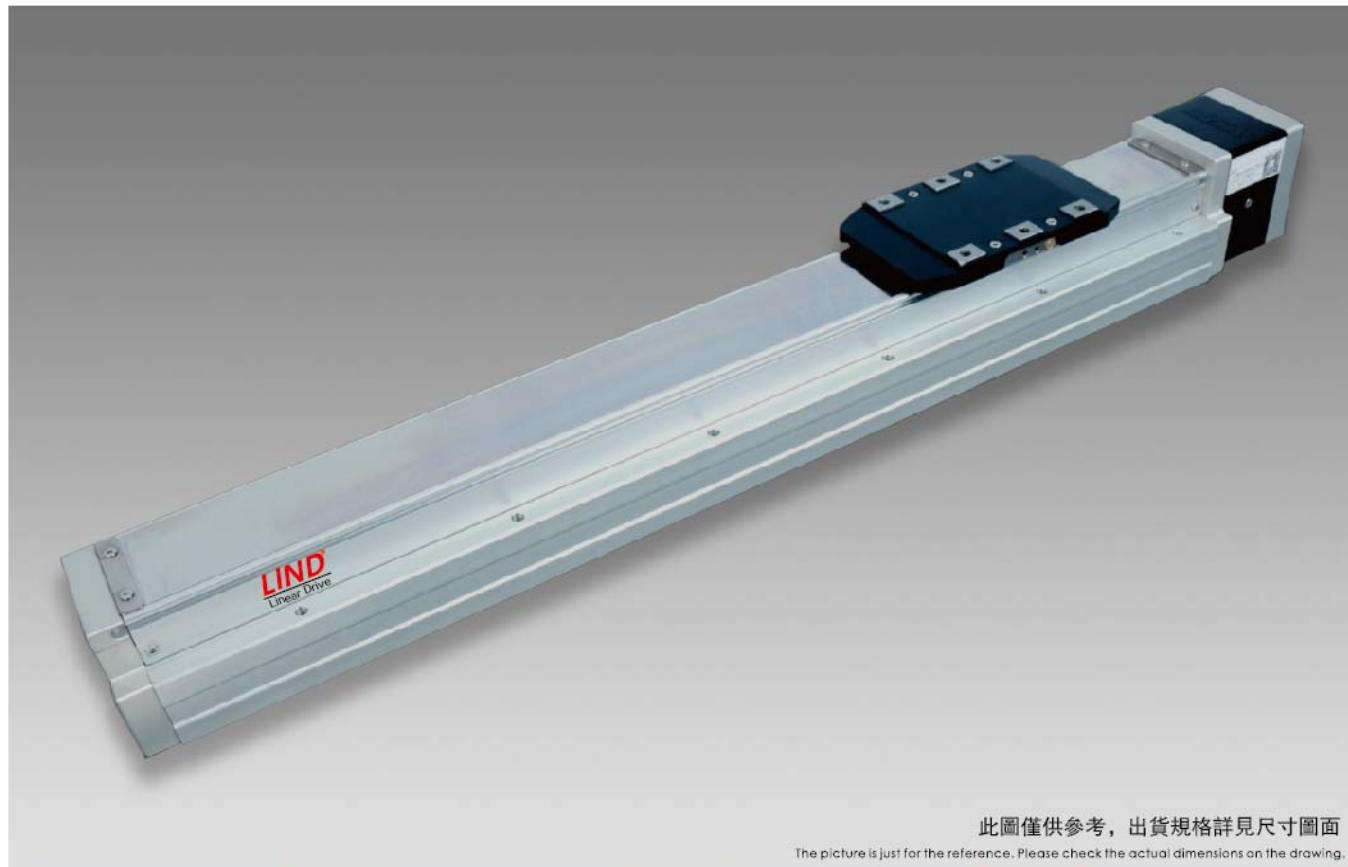

此圖僅供參考，出貨規格詳見尺寸圖面
The picture is just for the reference. Please check the actual dimensions on the drawing.

- 最大行程1000mm Maximum Stroke
- 最高速度1600mm/s Maximum Speed
- 馬達容量400W Motor Output
- 滾珠螺桿 Ø 16mm Ball Screw

型號表示方式 Ordering Method

LBTH120 - L10 - S100 - BC - M40B - C 4 - 0001

本體型號 Model

行程 Stroke 50-1000mm 50間隔50mm 50 mm Pitch

馬達位置 Motor Position

BC	馬達外露 Motor Exposed
BM	馬達下折 Motor Bottom Side
BL	馬達左折 Motor Left Side
BR	馬達右折 Motor Right Side

馬達品牌/功率 Motor Brand, Power Output

M	三菱 Mitsubishi	05	-	B
P	松下 Panasonic	10	-	
Y	安川 Yaskawa	20	-	
T	臺達 Delta	40	400W	

原點感應器 Home Sensor

C	馬達側 Motor Side
D	反馬達側 Opposite Motor Side
	無SENSOR No Sensor
E	無SENSOR No Sensor

端點極限感應器 Limit Sensor

3	1祇 1Pc
4	2祇 2Pc
	無SENSOR No Sensor
5	無SENSOR No Sensor

螺桿導程 Ball Screw Lead

5	5mm
10	10mm
20	20mm
32	32mm

*若無制動則不表示。 If No Brake No Description.

*選擇行程50時，有以下限制。 When the stroke is 50 mm, the sensor installation has the following restrictions:

- 無法選用C4 D4規格。 C4&D4 will not be available for installation (order) option.
- 原點與極限需放置于不同側。 Home sensor and limit sensor has to be installed on the different side of body.
- 滑座左右兩側皆需安裝感應片

基本樣式 Specification

規格 Spec	重複位置精度(mm) Repeatability (mm)	±0.01			
	螺桿導程(mm) Ball Screw Lead (mm)	5	10	20	32
	最高速度(mm/s) Maximum Speed (mm/s)	250	500	1000	1600
	最大可搬重量(kg) Horizontal (kg)	110	88	40	30
	Repeatability (kg) 垂直使用(kg) Vertical (kg)	33	22	10	8
部品 Parts	定格推力(N) Rated Thrust (N)	1388	694	347	218
	標準行程(mm) Stroke Pitch (mm)	50-1000mm/50間隔 50 mm Pitch			
	AC伺服馬達容量(W) AC Servo Motor Output (W)	400			
	滾珠螺桿外徑φ (mm) Ball Screw Ø (mm)	C7Ø16			
	聯軸器(mm) Coupling (mm)	10X14			
原點感應器 Home Sensor	外挂 Outside	FF-U674(NPN)			

*行程超過750時，會產生螺桿偏擺，此時請將速度調降。
When the stroke is over 750 mm, the run-out of the ballscrew will occur. we recommend to low down the working speed under this circumstances.
*馬達加減速設定0.2秒。
Acceleration and deceleration value is set 0.2 second.

容許負載力矩表 Allowable Overhang

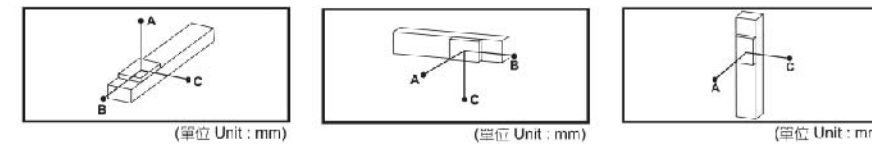

水平安裝 Horizontal Installation	A	B	C
導程 5 Lead 5	60kg	2850	250 340
導程 10 Lead 10	30kg	2850	490 600
導程 20 Lead 20	10kg	3400	1250 1400
導程 32 Lead 32	15kg	1100	570 550

壁掛安裝 Wall Installation	A	B	C
導程 5 Lead 5	55kg	280	280 3300
導程 10 Lead 10	35kg	400	410 2500
導程 20 Lead 20	12kg	900	1070 3000
導程 32 Lead 32	15kg	440	570 1050

垂直安裝 Vertical Installation	A	C
導程 5 Lead 5	15kg	1200 331
導程 10 Lead 10	10kg	1600 589
導程 20 Lead 20	7kg	1800 935
導程 32 Lead 32	5kg	1600 550

靜態容許負載慣量 Static Loading Moment

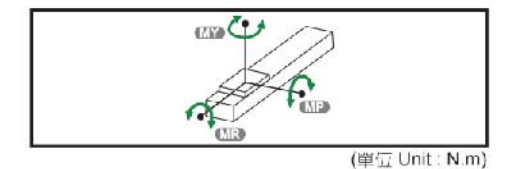

MY	1168
MP	606
MR	606

*力矩表所表示的數據，代表重心。
The torque value in the chart indicate the center of gravity.
*符合型錄規範的正常試用下，保證壽命為10000公裏。
Operation life is 10,000km when the product is using under the specified conditions.
*側吊使用無法套用標準規範，如有需求請諮詢我業務。
Data information is not for ceiling-mount inverse use. Contact us for the details if you want to apply ceiling-mount inverse usage.

搭配伺服馬達一覽表 Suitable Motor Brand

品牌 Brand	馬達記號 Mark	制動有無 Brake	馬達容量 Watt	電源電壓 AC-Voltage	伺服馬達型號 Motor Model	驅動器型號 Driver Model
三菱 Mitsubishi	M	無制動 (水平式樣) No Brake (Horizontal Type)	400	220	HG-KR43	MR-J4-40A
		有制動 (垂直式樣) With Brake (Horizontal Type)	400	220	HG-KR43B	MR-J4-40A
松下 Panasonic	P	無制動 (水平式樣) No Brake (Horizontal Type)	400	220	MSMD042G1U	MBDHT2510
		有制動 (垂直式樣) With Brake (Horizontal Type)	400	220	MSMD042G1V	MBDHT2510
臺達 Delta	T	無制動 (水平式樣) No Brake (Horizontal Type)	400	220	ECMA-C20604ES	ASD-B20421-B
		有制動 (垂直式樣) With Brake (Horizontal Type)	400	220	ECMA-C20604FS	ASD-B20421-B

BC馬達外露 Motor Exposed

單位: mm

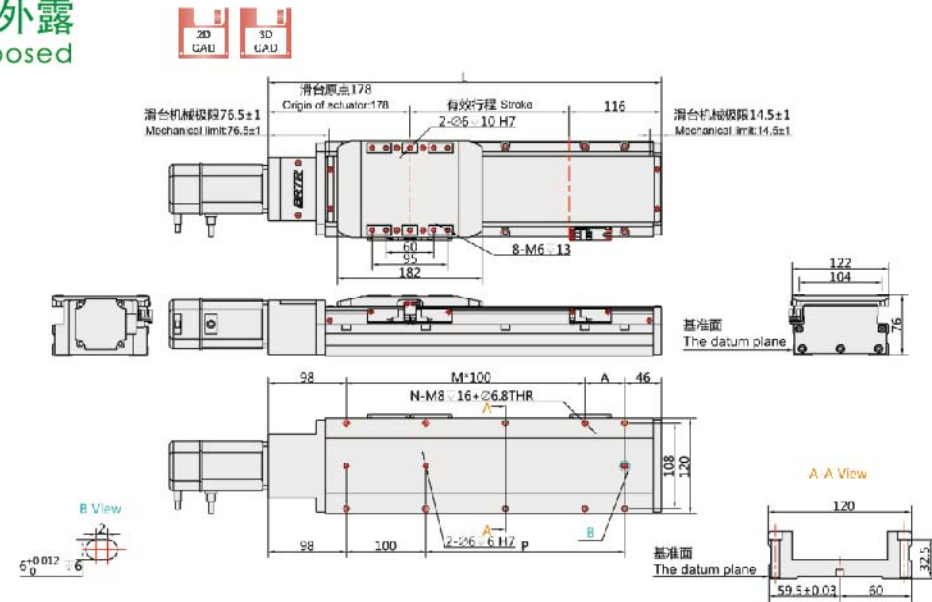

有效行程	标准行程																容许行程																							
	50	100	150	200	250	300	350	400	450	500	550	600	650	700	750	800	850	900	950	1000	50	100	150	200	250	300	350	400	450	500	550	600	650	700	750	800	850	900	950	1000
L	344	394	444	494	544	594	644	694	744	794	844	894	944	994	1044	1094	1144	1194	1244	1294	324.5	374.5	424.5	474.5	524.5	574.5	624.5	674.5	724.5	774.5	824.5	874.5	924.5	974.5	1024.5	1074.5	1124.5	1174.5	1224.5	1274.5
A	100	50	100	50	100	50	100	50	100	50	100	50	100	50	100	50	100	50	100	50	100	50	100	50	100	50	100	50	100	50	100	50	100	50	100	50	100	50	100	50
M	1	2	2	3	3	4	4	5	5	6	6	7	7	8	8	9	9	10	10	11	1	2	2	3	3	4	4	5	5	6	6	7	7	8	8	9	9	10	10	11
N	6	8	8	10	10	12	12	14	14	16	16	18	18	20	20	22	22	24	24	26	6	8	8	10	10	12	12	14	14	16	16	18	18	20	20	22	22	24	24	26
P	100	150	200	250	300	350	400	450	500	550	600	650	700	750	800	850	900	950	1000	1050	100	150	200	250	300	350	400	450	500	550	600	650	700	750	800	850	900	950	1000	1050
KG	5.05	5.4	5.75	6.1	6.45	6.8	7.15	7.5	7.85	8.2	8.55	8.9	9.25	9.6	9.95	10.3	10.65	11	11.35	11.7	5.25	5.6	5.95	6.3	6.65	7	7.35	7.7	8.05	8.4	8.75	9.1	9.45	9.8	10.15	10.85	11.2	11.55	11.9	12.25

BL馬達左折 Motor Left Side

單位: mm

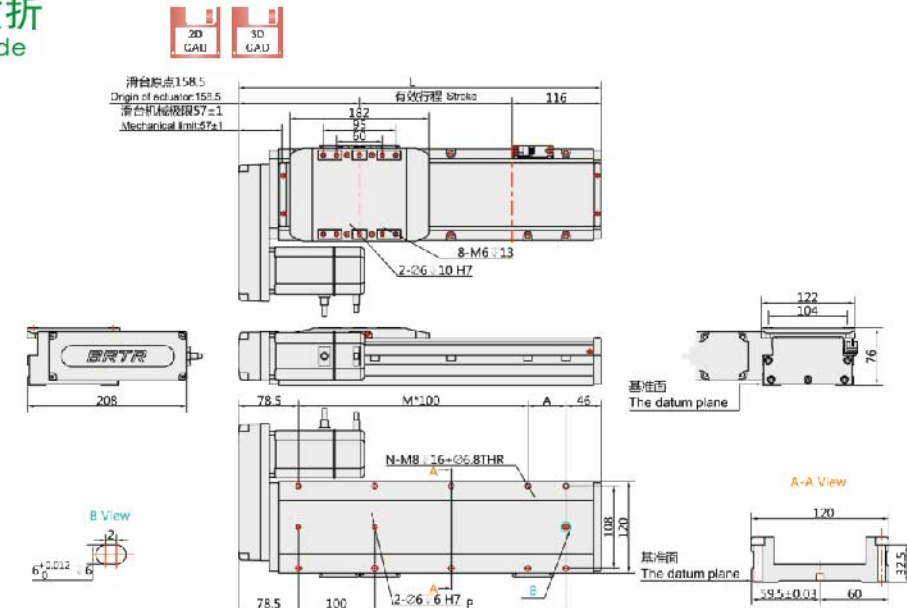

有效行程	标准行程																容许行程																							
	50	100	150	200	250	300	350	400	450	500	550	600	650	700	750	800	850	900	950	1000	50	100	150	200	250	300	350	400	450	500	550	600	650	700	750	800	850	900	950	1000
L	324.5	374.5	424.5	474.5	524.5	574.5	624.5	674.5	724.5	774.5	824.5	874.5	924.5	974.5	1024.5	1074.5	1124.5	1174.5	1224.5	1274.5	324.5	374.5	424.5	474.5	524.5	574.5	624.5	674.5	724.5	774.5	824.5	874.5	924.5	974.5	1024.5	1074.5	1124.5	1174.5	1224.5	1274.5
A	100	50	100	50	100	50	100	50	100	50	100	50	100	50	100	50	100	50	100	50	100	50	100	50	100	50	100	50	100	50	100	50	100	50	100	50	100	50	100	50
M	1	2	2	3	3	4	4	5	5	6	6	7	7	8	8	9	9	10	10	11	1	2	2	3	3	4	4	5	5	6	6	7	7	8	8	9	9	10	10	11
N	6	8	8	10	10	12	12	14	14	16	16	18	18	20	20	22	22	24	24	26	6	8	8	10	10	12	12	14	14	16	16	18	18	20	20	22	22	24	24	26
P	100	150	200	250	300	350	400	450	500	550	600	650	700	750	800	850	900	950	1000	1050	100	150	200	250	300	350	400	450	500	550	600	650	700	750	800	850	900	950	1000	1050
KG	5.25	5.6	5.95	6.3	6.65	7	7.35	7.7	8.05	8.4	8.75	9.1	9.45	9.8	10.15	10.85	11.2	11.55	11.9	12.25	5.25	5.6	5.95	6.3	6.65	7	7.35	7.7	8.05	8.4	8.75	9.1	9.45	9.8	10.15	10.85	11.2	11.55	11.9	12.25

BM馬達下折 Motor Bottom Side

單位: mm

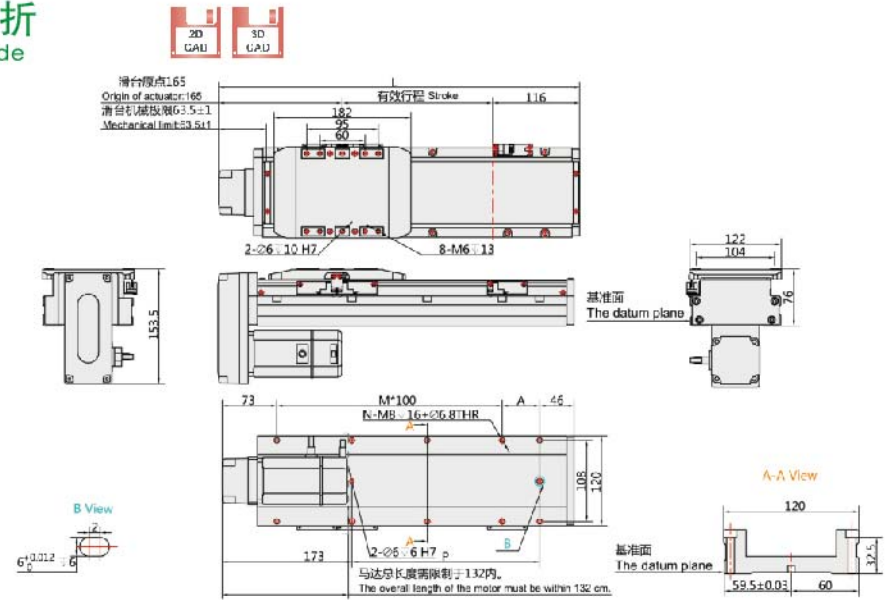

有效行程	标准行程																容许行程																							
	50	100	150	200	250	300	350	400	450	500	550	600	650	700	750	800	850	900	950	1000	50	100	150	200	250	300	350	400	450	500	550	600	650	700	750	800	850	900	950	1000
L	334.5	384.5	434.5	484.5	534.5	584.5	634.5	684.5	734.5	784.5	834.5	884.5	934.5	984.5	1034.5	1084.5	1134.5	1184.5	1234.5	1284.5	334.5	384.5	434.5	484.5	534.5	584.5	634.5	684.5	734.5	784.5	834.5	884.5	934.5	984.5	1034.5	1084.5	1134.5	1184.5	1234.5	1284.5
A	100	50	100	50	100	50	100	50	100	50	100	50	100	50	100	50	100	50	100	50	100	50	100	50	100	50	100	50	100	50	100	50	100	50	100	50	100	50	100	50
M	0	1	1	2	2	3	3	4	4	5	5	6	6	7	7	8	8	9	9	10	0	1	1	2	2	3	3	4	4	5	5	6	6	7	7	8	8	9	9	10
N	4	6	6	8	8	10	10	12	12	14	14	16	16	18	18	20	20	22	22	24	4	6	6	8	8	10	10	12	12	14	14	16	16	18	18	20	20	22	22	24
P	100	150	200	250	300	350	400	450	500	550	600	650	700	750	800	850	900	950	1000	1050	100	150	200	250	300	350	400	450	500	550	600	650	700	750	800	850	900	950	1000	1050
KG	5.21	5.56	5.91	6.26	6.61	6.96	7.31	7.66	8.01	8.36	8.71	9.06	9.41	9.76	10.11	10.46	10.81	11.16	11.51	11.86	5.21	5.56	5.91	6.26	6.61	6.96	7.31	7.66	8.01	8.36	8.71	9.06	9.41	9.76	10.11	10.46	10.81	11.16	11.51	11.86

BR馬達右折 Motor Right Side

單位: mm

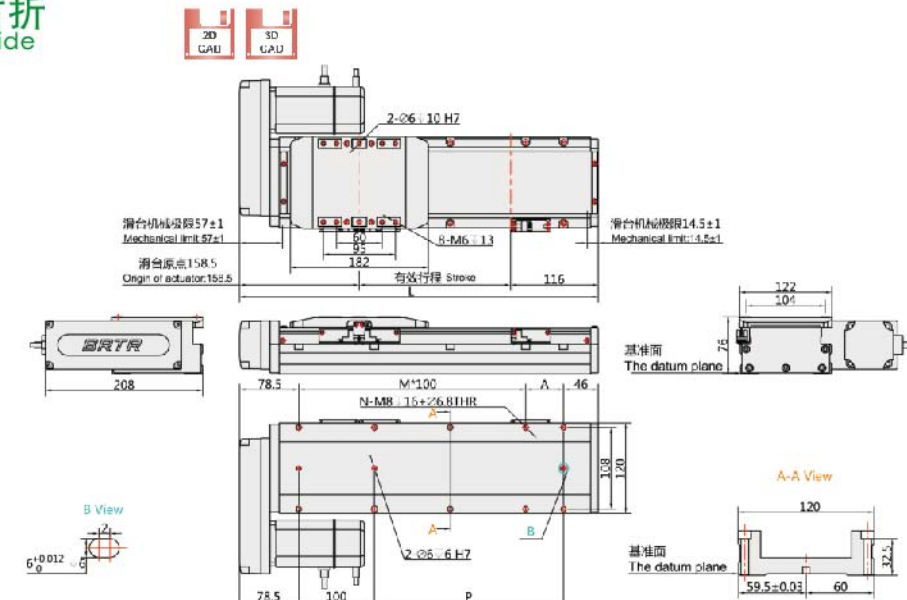

有效行程	标准行程																容许行程																							
	50	100	150	200	250	300	350	400	450	500	550	600	650	700	750	800	850	900	950	1000	50	100	150	200	250	300	350	400	450	500	550	600	650	700	750	800	850	900	950	1000
L	324.5	374.5	424.5	474.5	524.5	574.5	624.5	674.5	724.5	774.5	824.5	874.5	924.5	974.5	1024.5	1074.5	1124.5	1174.5	1224.5	1274.5	324.5	374.5	424.5	474.5	524.5	574.5	624.5	674.5	724.5	774.5	824.5	874.5	924.5	974.5	1024.5	1074.5	1124.5	1174.5	1224.5	1274.5
A	100	50	100	50	100	50	100	50	100	50	100	50	100	50	100	50	100	50	100	50	100	50	100	50	100	50	100	50	100	50	100	50	100	50	100	50	100	50	100	50
M	1	2	2	3	3	4	4	5	5	6	6	7	7	8	8	9	9	10	10	11	1	2	2	3	3	4	4	5	5	6	6	7	7	8	8	9	9	10	10	11
N	6	8	8	10	10	12	12	14	14	16	16	18	18	20	20	22	22	24	24	26	6	8	8	10	10	12	12	14	14	16	16	18	18	20	20	22	22	24	24	26
P	100	150	200	250	300	350	400	450	500	550	600	650	700	750	800	850	900	950	1000	1050	100	150	200	250	300	350	400	450	500	550	600	650	700	750	800	850	900	950	1000	1050
KG	5.25	5.6	5.95	6.3	6.65	7	7.35	7.7	8.05	8.4	8.75	9.1	9.45	9.8	10.15	10.85	11.2	11.55	11.9	12.25	5.25	5.6	5.95	6.3	6.65	7	7.35	7.7	8.05	8.4	8.75	9.1	9.45	9.8	10.15	10.85	11.2	11.55	11.9	12.25

各分公司

SUBSIDIARIES

元基機械股份有限公司 Yuanji Machinery Co., Ltd.

地址：臺中縣太平市永平路二段478號

電話：(04) 22798655

傳真：(04) 22777776

無錫靈德自動化科技有限公司 WUXI LIND Automation Tech Co.,Ltd

地址：無錫市錫山經濟開發區春筍東路77號

電話：0510-88551360

傳真：0510-88551365

網址：www.lind-world.com

長沙靈德科技有限公司 CHANGSHA LIND Automation Tech Co.,Ltd

地址：長沙市天心區時代陽光大道西108號

電話：15874847922漆經理

武漢靈德機械設備有限公司 WUHAN LIND Automation Tech Co.,Ltd

地址：武漢市經濟技術開發區經開萬達廣場B3-2504

電話：027-84852770 13207100450陳經理

傳真：027-84852770

上海靈德機器人有限公司 SHANGHAI LIND Automation Tech Co.,Ltd

上海市嘉定區環城路2222號1幢J

電話：021-59135603 13661810502詹經理

傳真：021-59130034

靈德(臺州)自動化科技有限公司 TAIZHOU LIND Automation Tech Co.,Ltd

地址：臺州市路橋區東路橋大道發達大廈9F

電話：0576-82417206 13336732739 崔經理

傳真：0576-88327439

靈德電氣自動化(青島)有限公司 QINGDAO LIND Automation Tech Co.,Ltd

地址：青島市李滄區興華路17號2單元203

電話：18153232141宮經理

成都靈德自動化科技有限公司 CHENGDU LIND Automation Tech Co.,Ltd

地址：成都市高新西區德源(菁蓉)鎮靜園東路218號

電話：13548013776 吳經理

常州靈德自動化科技有限公司 CHANGSHU LIND Automation Tech Co.,Ltd

地址：常州市武進區招商花園城6乙403

電話：18661176320譚經理

深圳靈德自動化科技有限公司 SHENZHEN Automation Tech Co.,Ltd

地址：深圳市龍華區大浪街道華繁路289號B棟304

電話：0755-29581836 13823138936郭經理

傳真：0755-29581835

